

**TOSHIBA CMOS INTEGRATED CIRCUITS SILICON MONOLITHIC****TCA62753FUG****Charge Pump type DC/DC Converter for White LED Driver**

The TCA62753FUG is a charge pump type DC/DC Converter specially designed for constant current driving of White LED. This IC can outputs LED current 100mA to 3.0-5.5V input. This IC is especially for driving back light white LEDs in LCD of PDA, Cellular Phone, or Handy Terminal Equipment. This IC is Pb-free product.

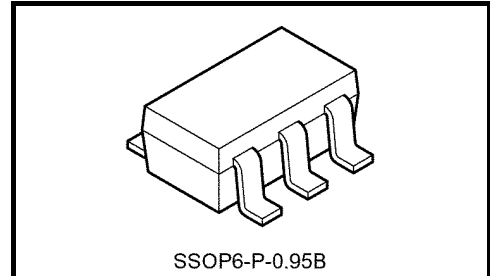

Weight: 0.016 g (Typ.)

**Features**

- Power supply Voltage :  $V_{IN} = 2.7V \sim 5.5V$
- Output Voltage :  $V_{OUT} = 5.0V \pm 6\%$
- Output Current : 100mA ( $V_{IN} = 3.0V$  or more)  
50mA ( $V_{IN} = 2.7V$  or more)
- Switching Frequency : 1MHz (Typ.)
- Integrated protection circuit : Thermal Shut Down function  
Over current limitation function
- External parts are few. : It is possible to driving of LED with 3 capacitors.  
(It is each one capacitor for the Input, for the Output, and for the Charge pump)
- Package : SSOP6-P-0.95B

**Pin Assignment (Top view)**

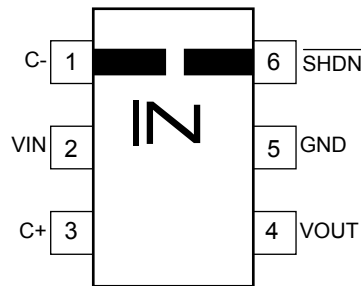

**Explanation of the Terminal**

No.	Symbol	Function
1	C-	Capacitance connection terminal for charge pump.
2	V <sub>IN</sub>	Power supply terminal.
3	C+	Capacitance connection terminal for charge pump.
4	V <sub>OUT</sub>	Output terminal.
5	GND	GND terminal.
6	SHDN	Logic input terminal. "H" input on this pin enables the IC to operate while "L" input causes it to shut down. The behavior of the IC is unpredictable if the input on the pin is undefined. Ensure that the pin is tied to either "H" or "L" level. In the condition of V <sub>IN</sub> = 2.7V or less, please make it to "L" level.

**Block Diagram**

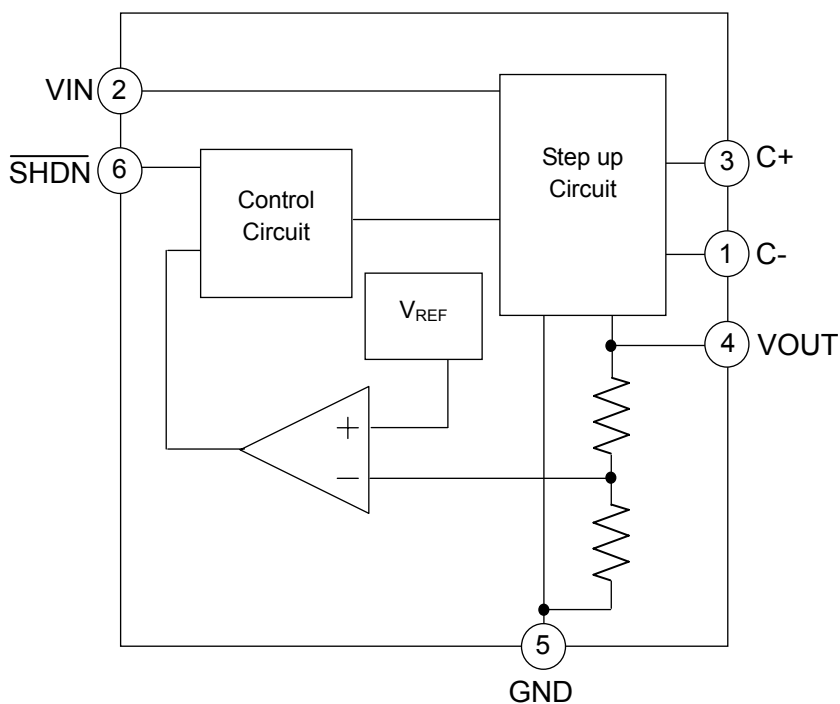

I/O Equivalent Pin Circuits

1. C-

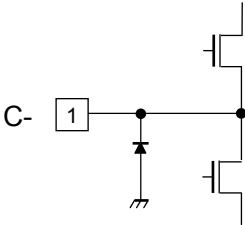

2. VIN

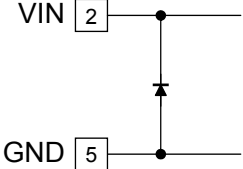

3. C+

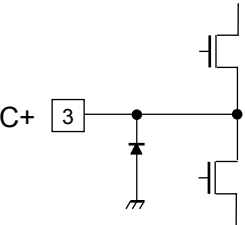

4. VOUT

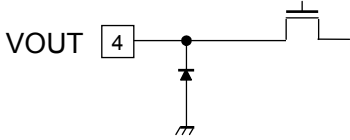

6. SHDN

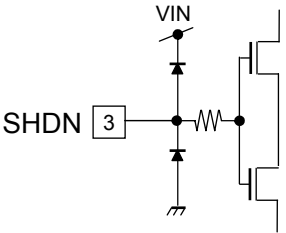

## Absolute Maximum Ratings (T<sub>opr</sub> = 25°C)

Characteristics	Symbol	Ratings	Unit
Power supply voltage	V <sub>IN</sub>	-0.3 ~ +6.0	V
Input Voltage	V <sub>SHDN</sub>	-0.3 ~ V <sub>IN</sub> + 0.3 *Note1	V
Output Voltage	V <sub>OUT</sub>	-0.3 ~ +6.0	V
Power Dissipation	P <sub>D</sub>	0.41 (Device)	W
		0.47 (with PCB) *Note2	
Thermal resistance	R <sub>th(j-a)</sub>	300 (Device)	°C/W
		260 (with PCB)	
Operating temperature range	T <sub>opr</sub>	-40 ~ +85	°C
Storage temperature	T <sub>stg</sub>	-55 ~ +150	°C
Maximum junction temperature	T <sub>j</sub>	150	°C

Note1: However, do not exceed 6V.

Note2: When every time the ambient temperature gets over 25°C with 1°C, the allowable loss must reduce 3.8mW/°C more than maximum rated value. (When on PCB.)

## Recommended Operating Condition (unless otherwise specified, T<sub>opr</sub> = -40 ~ 85°C)

Characteristics	Symbol	Test Conditions	Min.	Typ.	Max.	Unit
Power supply voltage	V <sub>IN</sub>	-	2.7	-	5.5	V
Capacitance for Charge Pump	C	-	-	1.0	-	mA
Capacitance for input	C <sub>IN</sub>	-	1.0	2.2	10	μF
Capacitance for output	C <sub>OUT</sub>	-	1.0	2.2	10	μF

## Electrical Characteristics (unless otherwise specified, V<sub>IN</sub> = 3.6V, T<sub>opr</sub> = 25°C)

Characteristics	Symbol	Test Conditions	Min.	Typ.	Max.	Unit
Output Voltage	V <sub>OUT</sub>	V <sub>IN</sub> = 2.7 ~ 3.0V, I <sub>OUT</sub> = 50mA or less	4.7	5.0	5.3	V
		V <sub>IN</sub> = 3.0 ~ 5.0V, I <sub>OUT</sub> = 100mA or less	4.7	5.0	5.3	
Operating consumption current	I <sub>IN</sub>	I <sub>OUT</sub> = 0mA, V <sub>SHDN</sub> = V <sub>IN</sub>	-	-	3	mA
Quiescent consumption current	I <sub>IN</sub>	V <sub>IN</sub> = 2.7 ~ 5.5V I <sub>OUT</sub> = 0mA, V <sub>SHDN</sub> = 0V	-	0.01	1	μA
SHDN terminal H level input voltage	V <sub>SHDNH</sub>	V <sub>IN</sub> = 2.7 ~ 5.5V	1.3	-	V <sub>IN</sub>	V
SHDN terminal L level input voltage	V <sub>SHDNL</sub>	V <sub>IN</sub> = 2.7 ~ 5.5V	0	-	0.3	V
SHDN terminal current	I <sub>SHDNH</sub>	V <sub>SHDN</sub> = V <sub>IN</sub>	-1	-	1	μA
	I <sub>SHDNL</sub>	V <sub>SHDN</sub> = 0V	-1	-	1	
Clock Frequency	f <sub>OSC</sub>	V <sub>SHDN</sub> = 3.6V	0.7	1	1.3	MHz
Short Circuit Current	I <sub>SC</sub>	V <sub>OUT</sub> = GND, V <sub>SHDN</sub> = 3.6V	-	250	550	mA

Note1: This characteristic is measured with the test circuit described to page 5.

**Test Circuit**

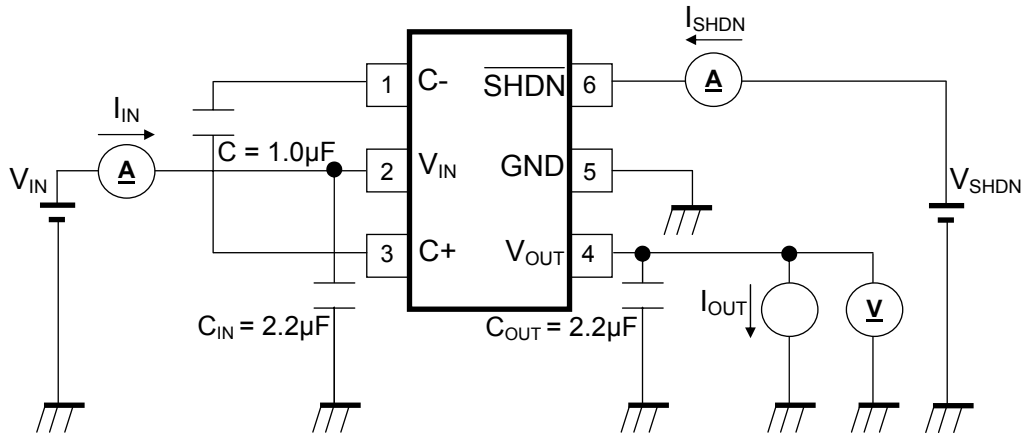

**The example of Application Circuit**

\*These application examples are provided for reference only.

\*Thorough evaluation and testing should be implemented when designing your application's mass production design.

**The example 1) Drive of 5 LEDs**

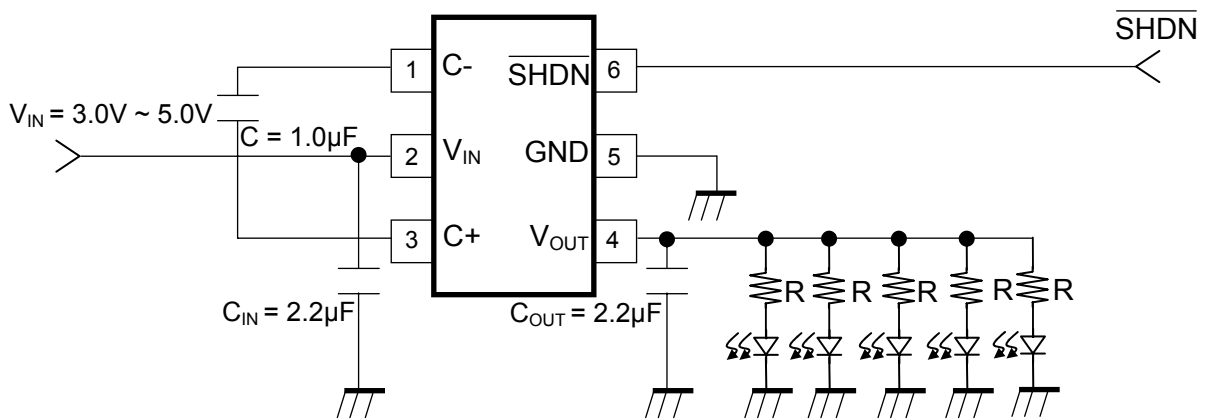

\*The LED current becomes 20mA by  $R = 20\Omega$ . (For LED  $V_f = 3.6V$ )

**The example 2) 5V power supply**

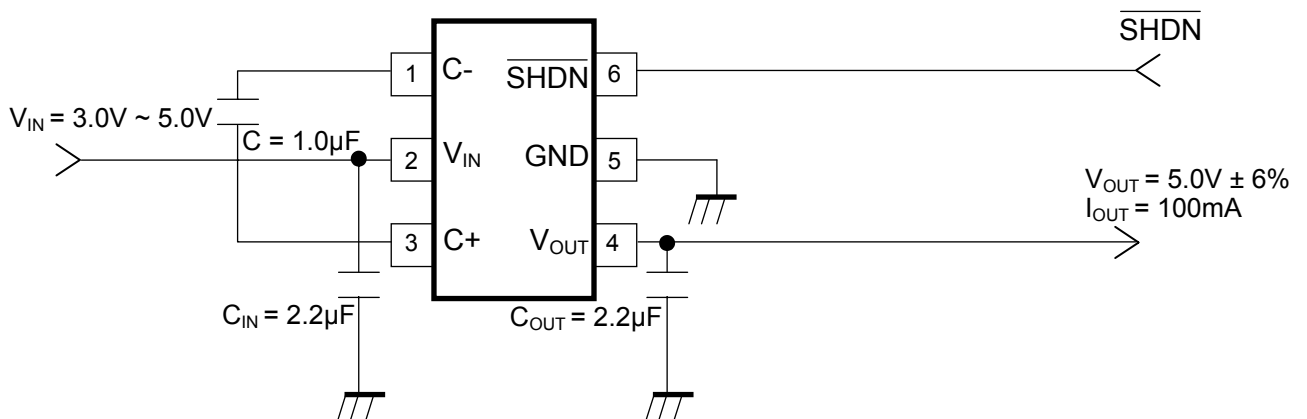

## Usage Precautions

### ■About the capacitor

Please connect C/C<sub>IN</sub>/C<sub>OUT</sub> as much as possible near the pin for best performance.  
Please select the ceramic capacitor that ESR (Equivalent Series Resistor) is low.

The input capacitor (C<sub>IN</sub>) is effective to decrease the impedance of power supply and also input current is averaged. The capacitance values of C<sub>IN</sub> will recommend 1.0μF to 10μF.

The output capacitor (C<sub>OUT</sub>) is effective to decrease the ripple noise of the output line.  
The capacitance values of C<sub>OUT</sub> will recommend 1.0μF to 10μF.

The flying capacitor (C) is a capacitor for the Step-up operation.  
The capacitance values of C will recommend 1.0μF.

Capacitance values of the ceramic capacitor changes greatly depending on the temperature and the input voltage.

Please confirm necessary Capacitance values can be secured in all temperatures and the total applied voltages.

### ■About the output ability

This product outputs 5V ± 6% from the terminal V<sub>OUT</sub> in input voltage V<sub>IN</sub> = 2.7V or more.  
The output current ability is 50mA at V<sub>IN</sub> = 2.7V ~ 3.0V. Moreover, it is 100mA at V<sub>IN</sub> = 3.0V or more.

### ■Thermal shutdown function

The thermal shutdown circuit works when the junction temperature exceeds 150°C (Typ.), and IC stops operating.

Operation begins again when the junction temperature falls.  
(This function is not included in the product inspection.)

### ■Others

\*When the capacitor connected with C+ terminal and C- terminal comes off.

The step up operation is not done.

The power supply current flows because the current route is generated from the terminal VIN to the terminal GND / the terminal VOUT.

However, the over current limitation function works, and the power supply current is limited to 250mA (Typ.).

\*When the capacitor connected with I/O comes off

The step up operation is done. However, the voltage ripple of I/O grows, and the output ability decreases.

\*When terminal C+ and terminal C- are short-circuited

The step up operation is not done.

The power supply current flows because the current route is generated from the terminal VIN to the terminal GND.

However, the over current limitation function works, and the power supply current is limited to 250mA (Typ.).

\*When the terminal  $\overline{\text{SHDN}}$  is an opening

The behavior of the IC is unpredictable if the input on the pin is undefined. Ensure that the pin is tied to either "H" or "L" level.

\*When the terminal VOUT is short-circuited to GND

The over current limitation function works, and the power supply current is limited to 250mA (Typ.).

\*When the terminal VOUT is an opening

The output voltage is controlled with 5V ± 6%.

**Reference data**

\*This data is a reference value, and no guarantee value.

**Output Current – Output Voltage**

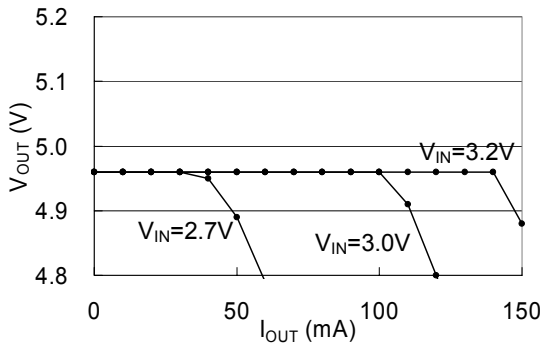

**Power supply Voltage – Output Voltage**

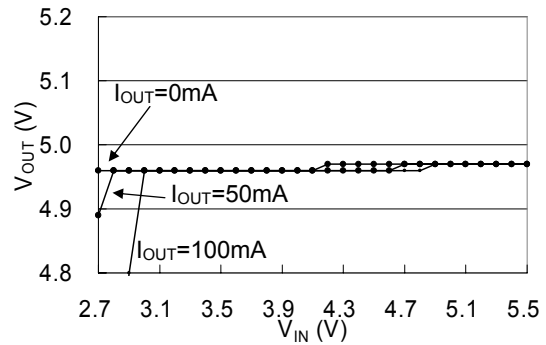

**Output Current – Efficiency**

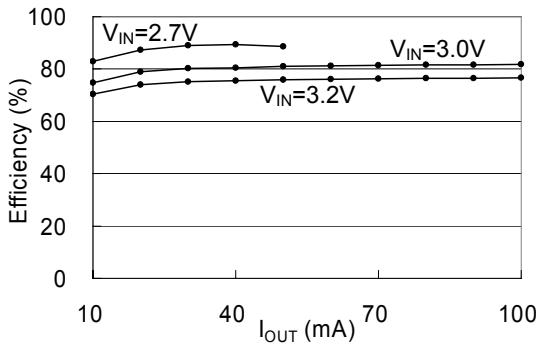

**Power supply Voltage – Efficiency**

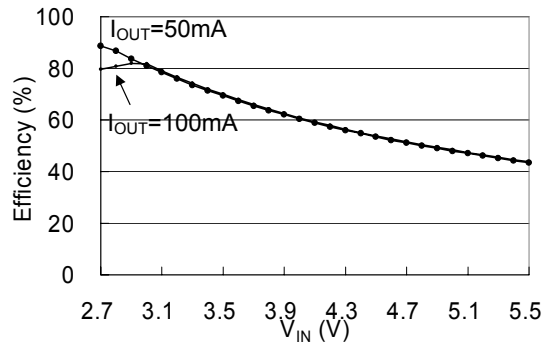

**Power supply Voltage – Input Current**

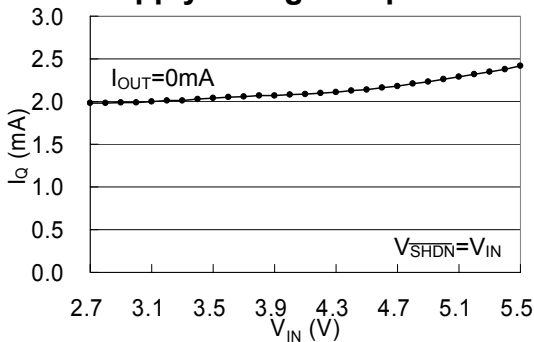

**Power supply Voltage – Clock**

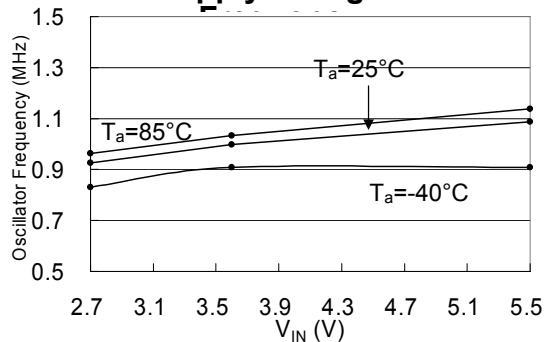

**Evaluation conditions**

$T_a = 25^\circ\text{C}$  (unless otherwise specified)

$C = 1.0\mu\text{F}$  (TDK Corporation C1608JB1C105K)

$C_{IN}/C_{OUT} = 2.2\mu\text{F}$  (TDK Corporation C1608JB0J225M)

Package Dimensions

SSOP6-P-0.95B

Unit: mm

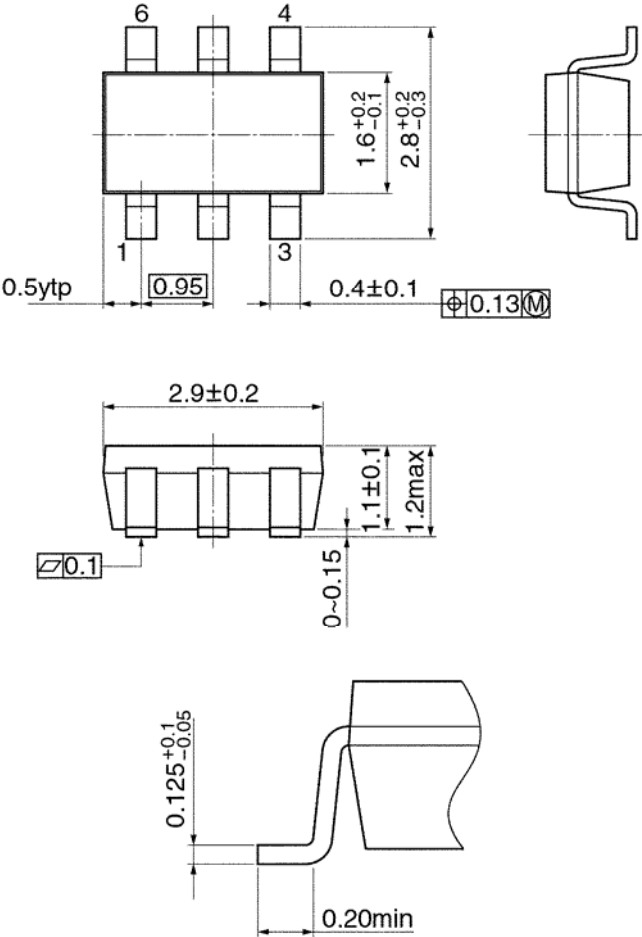

Weight: 0.016 g (Typ.)



## Notes on Contents

### 1. Block Diagrams

Some of the functional blocks, circuits, or constants in the block diagram may be omitted or simplified for explanatory purposes.

### 2. Equivalent Circuits

The equivalent circuit diagrams may be simplified or some parts of them may be omitted for explanatory purposes.

### 3. Application Circuits

The application circuits shown in this document are provided for reference purposes only. Thorough evaluation is required, especially at the mass production design stage.

Toshiba does not grant any license to any industrial property rights by providing these examples of application circuits.

### 4. Test Circuits

Components in the test circuits are used only to obtain and confirm the device characteristics. These components and circuits are not guaranteed to prevent malfunction or failure from occurring in the application equipment.

## IC Usage Considerations

### Notes on handling of ICs

- [1] The absolute maximum ratings of a semiconductor device are a set of ratings that must not be exceeded, even for a moment. Do not exceed any of these ratings.  
Exceeding the rating(s) may cause the device breakdown, damage or deterioration, and may result injury by explosion or combustion.
- [2] Use an appropriate power supply fuse to ensure that a large current does not continuously flow in case of over current and/or IC failure. The IC will fully break down when used under conditions that exceed its absolute maximum ratings, when the wiring is routed improperly or when an abnormal pulse noise occurs from the wiring or load, causing a large current to continuously flow and the breakdown can lead smoke or ignition. To minimize the effects of the flow of a large current in case of breakdown, appropriate settings, such as fuse capacity, fusing time and insertion circuit location, are required.
- [3] If your design includes an inductive load such as a motor coil, incorporate a protection circuit into the design to prevent device malfunction or breakdown caused by the current resulting from the inrush current at power ON or the negative current resulting from the back electromotive force at power OFF. IC breakdown may cause injury, smoke or ignition.  
Use a stable power supply with ICs with built-in protection functions. If the power supply is unstable, the protection function may not operate, causing IC breakdown. IC breakdown may cause injury, smoke or ignition.
- [4] Do not insert devices in the wrong orientation or incorrectly.  
Make sure that the positive and negative terminals of power supplies are connected properly. Otherwise, the current or power consumption may exceed the absolute maximum rating, and exceeding the rating(s) may cause the device breakdown, damage or deterioration, and may result injury by explosion or combustion.  
In addition, do not use any device that is applied the current with inserting in the wrong orientation or incorrectly even just one time.
- [5] Carefully select external components (such as inputs and negative feedback capacitors) and load components (such as speakers), for example, power amp and regulator.  
If there is a large amount of leakage current such as input or negative feedback condenser, the IC output DC voltage will increase. If this output voltage is connected to a speaker with low input withstand voltage, overcurrent or IC failure can cause smoke or ignition. (The over current can cause smoke or ignition from the IC itself.) In particular, please pay attention when using a Bridge Tied Load (BTL) connection type IC that inputs output DC voltage to a speaker directly.

About solderability, following conditions were confirmed

- Solderability

- (1) Use of Sn-37Pb solder Bath

- solder bath temperature = 230°C
    - dipping time = 5 seconds
    - the number of times = once
    - use of R-type flux

- (2) Use of Sn-3.0Ag-0.5Cu solder Bath

- solder bath temperature = 245°C
    - dipping time = 5 seconds
    - the number of times = once
    - use of R-type flux

## RESTRICTIONS ON PRODUCT USE

030619EBA

- The information contained herein is subject to change without notice.
- The information contained herein is presented only as a guide for the applications of our products. No responsibility is assumed by TOSHIBA for any infringements of patents or other rights of the third parties which may result from its use. No license is granted by implication or otherwise under any patent or patent rights of TOSHIBA or others.
- TOSHIBA is continually working to improve the quality and reliability of its products. Nevertheless, semiconductor devices in general can malfunction or fail due to their inherent electrical sensitivity and vulnerability to physical stress. It is the responsibility of the buyer, when utilizing TOSHIBA products, to comply with the standards of safety in making a safe design for the entire system, and to avoid situations in which a malfunction or failure of such TOSHIBA products could cause loss of human life, bodily injury or damage to property.  
In developing your designs, please ensure that TOSHIBA products are used within specified operating ranges as set forth in the most recent TOSHIBA products specifications. Also, please keep in mind the precautions and conditions set forth in the "Handling Guide for Semiconductor Devices," or "TOSHIBA Semiconductor Reliability Handbook" etc..
- The TOSHIBA products listed in this document are intended for usage in general electronics applications (computer, personal equipment, office equipment, measuring equipment, industrial robotics, domestic appliances, etc.). These TOSHIBA products are neither intended nor warranted for usage in equipment that requires extraordinarily high quality and/or reliability or a malfunction or failure of which may cause loss of human life or bodily injury ("Unintended Usage"). Unintended Usage include atomic energy control instruments, airplane or spaceship instruments, transportation instruments, traffic signal instruments, combustion control instruments, medical instruments, all types of safety devices, etc.. Unintended Usage of TOSHIBA products listed in this document shall be made at the customer's own risk.
- The products described in this document are subject to the foreign exchange and foreign trade laws.
- TOSHIBA products should not be embedded to the downstream products which are prohibited to be produced and sold, under any law and regulations.