

EVAL-AD7891-2CB

FEATURES

- Full-Featured Evaluation Board for the AD7891-2**
- EVAL-CONTROL BOARD Compatible**
- Stand Alone Capability**
- On-Board Analog Buffering and Reference**
- Various Linking Options**
- PC Software for Control and Data Analysis when used with EVAL-CONTROL BOARD**

INTRODUCTION

This Application Note describes the evaluation board for the AD7891-2 12-Bit A/D converter. The AD7891-2 is an eight channel data acquisition system that operates from a single +5 V supply and accepts input signals in the ranges 0 to +5 V, 0 to +2.5 V or ± 2.5 V. It incorporates an input multiplexer, an on-chip track/hold amplifier, an internal +2.5 V reference and on-chip versatile interface structures that allow both serial and parallel connection to a microprocessor. This flexible serial interface allows the AD7891-2 to connect directly to Digital Signal Processors (ADSP-2101, DSP56001, etc.) and Microcontrollers (8XC51, 68HC11, etc.). Full data on the AD7891-2 is available in the AD7891 data sheet available from Analog Devices and should be consulted in conjunction with this Application Note when using the Evaluation Board.

On-board components include an AD780 which is a pin programmable +2.5 V or +3V ultra high precision bandgap reference, a buffer amplifier to buffer the reference when using inputs in the ± 2.5 V range and two AD713 quad op-amps to buffer the analog inputs.

Interfacing to this board is through a 9-way D-type connector and a 96-way connector. This 96-way connector is compatible with the EVAL-CONTROL BOARD which is also available from Analog Devices. External sockets are provided for the conversion start input, analog inputs and an external reference input option.

OPERATING THE AD7891-2 EVALUATION BOARD

Power Supplies

This evaluation board has four analog power supply inputs: V_{DD} , DGND, +12 V and -12 V. The V_{DD} supply is nominally +5 V and is used to power the AD7891-2 and the on-board digital integrated circuits. The +12 V and -12 V supplies are used to power the AD713 quad op-amps and the AD780 voltage reference and the reference buffer. The DGND connection is to the digital ground plane. This DGND ground plane connects to the AGND ground plane at the AD7891-2. Therefore, it is recommended not to connect AGND and DGND elsewhere in the system. The various analog and digital supplies are provided through the power-supply terminals on the board. When using the AD7891-2 evaluation board with the EVAL-CONTROL BOARD, all supplies are provided by the EVAL-CONTROL BOARD.

All supplies are decoupled to ground with 10 μ F tantalum and 0.1 μ F ceramic disc capacitors. The +12 V and -12 V supplies for the amplifiers are decoupled to the AGND plane while the AV_{DD} supply for the AD7891 is decoupled to the AGND plane through a 10 μ F capacitor and to the DGND plane through a 0.1 μ F capacitor.

FUNCTIONAL BLOCK DIAGRAM

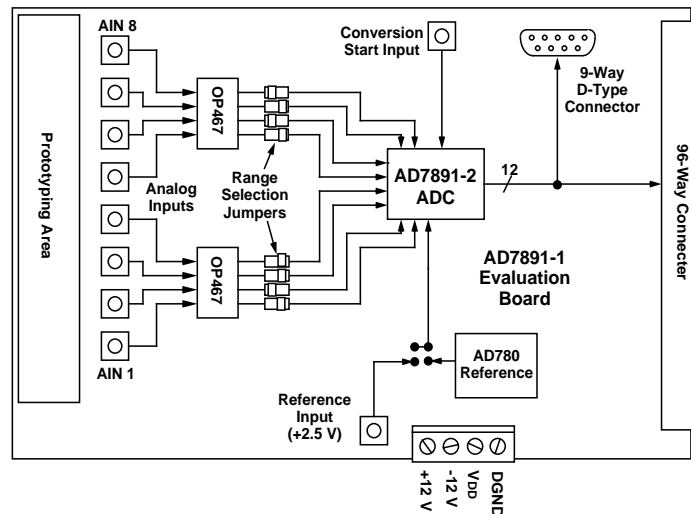

REV. A

Information furnished by Analog Devices is believed to be accurate and reliable. However, no responsibility is assumed by Analog Devices for its use, nor for any infringements of patents or other rights of third parties which may result from its use. No license is granted by implication or otherwise under any patent or patent rights of Analog Devices.

EVAL-AD7891-2CB

Link Options

There are thirty one link options on the evaluation board which must be set for the required operating setup before use. The functions of these options are outlined below.

Link No.	Function
LK1 - LK8	<p>LK1 to LK8 select the voltages applied to the inputs of the quad op-amp buffers. LK1 selects the voltage for channel 1, LK2 selects the voltage for channel 2 etc.</p> <p>In position A, the input is connected to the SMB connector.</p> <p>In position B, the input is connected to AGND. If no voltage is present at the SMB connector then the link should be in position B.</p>
LK9 - LK16	<p>LK9 to LK16 are used to select the voltages applied to the V_{INxA} inputs of the AD7891-2. LK9 selects the voltage that is applied to V_{IN1A}, LK10 selects the voltage applied to V_{IN2A} etc.</p> <p>In position A the buffered input voltage from $AINx$ is connected to V_{INxA}.</p> <p>In position B, V_{INxA} is connected to AGND.</p>
LK17 - LK24	<p>LK17 to LK24 are used to select the voltage applied to the V_{INxB} inputs of the AD7891-2. LK17 selects the voltage that is applied to V_{IN1B}, LK18 selects the voltage that is applied to V_{IN2B} etc.</p> <p>In position A, the buffered reference voltage is applied to V_{INxB}.</p> <p>In position B, the buffered input voltage from $AINx$ is connected to V_{INxB}.</p> <p>In position C, V_{INxB} is connected to AGND.</p>
LK25	<p>This link option selects the reference source for the AD7891 REF OUT/REF IN pin.</p> <p>With this link in position A, the reference connects to the SMB socket, SKT9.</p> <p>In position B, the AD780 +2.5V reference is selected as the reference for the AD7891-2.</p> <p>With this link out, the REF OUT/REF IN pin remains open-circuited, thus the reference source is the AD7891-2's internal reference.</p>
LK26	<p>This link selects the V_{DD} source.</p> <p>In position A, the V_{DD} supply is taken from the external V_{DD} connector.</p> <p>In position B, the V_{DD} supply is taken from the 96 way connector.</p>
LK27	<p>This link selects the +12V source.</p> <p>In position A, the +12V supply is taken from the external +12 V connector.</p> <p>In position B, the +12V supply is taken from the 96 way connector.</p>
LK28	<p>This link selects the -12 V source.</p> <p>In position A, the -12 V supply is taken from the external -12 V connector.</p> <p>In position B, the -12 V supply is taken from the 96 way connector.</p>
LK29	<p>This link option selects the voltage applied to the STANDBY pin of the AD7891-2. The voltage applied to the STANDBY pin can also be controlled from pin 9 of the 9-way D-type socket. If pin 9 of the 9-way D-type socket is used to control the voltage applied to the STANDBY pin then LK29 should be left unconnected.</p> <p>In position A, the STANDBY pin is connected to V_{DD}.</p> <p>In position B, the STANDBY pin is connected to DGND.</p>
LK30	<p>This link option selects the source for the \overline{CONVST} input of the AD7891-2.</p> <p>In position A, the \overline{CONVST} pin is connected to the FL0 pin on the 96-way connector. When using the evaluation board with the EVAL-CONTROL BOARD, there are two program options, one where the \overline{CONVST} signal is generated from the EVAL-CONTROL BOARD; the second where the \overline{CONVST} signal is externally supplied. When the internal \overline{CONVST} program is used, this link must be in position A.</p> <p>In position B, the signal applied to the SMB connector, SKT10 provides the \overline{CONVST} signal for the AD7891-2.</p>
LK31	<p>This link option selects the voltage applied to the MODE pin of the AD7891-2 and hence selects the interface mode used for the part.</p> <p>In position A, the MODE pin is connected to DGND, which selects the serial interface mode.</p> <p>In position B, the MODE pin is connected to V_{DD}, which selects the parallel interface mode.</p>

SET-UP CONDITIONS

Care should be taken before applying power and signals to the evaluation board to ensure that all link positions are as per the required operating mode. Table I shows the position in which all the links are set when the evaluation board is sent out.

Table I. Initial Link and Switch Positions

Link No.	Position	Function.
LK1	A	Input to buffer 1 comes from V_{IN1} SMB connector.
LK2 - LK8	B	Inputs to buffers 2 to 8 connected to AGND.
LK9 - LK16	A	V_{INxA} inputs are connected to relevant AINx buffers
LK17 - LK24	C	V_{INxB} inputs are connected to AGND
LK25	B	Connects the AD780's V_{OUT} pin to the AD7891-2's REF OUT/REF IN pin and thus selects the AD780 as the reference source for the AD7891-2
LK26	B	V_{DD} is supplied from the 96-way connector.
LK27	B	+12 V is supplied from the 96-way connector.
LK28	B	-12 V is supplied from the 96-way connector.
LK29	A	$\overline{\text{STANDBY}}$ pin is connected to V_{DD} and AD7891-2 does not go into $\overline{\text{STANDBY}}$ mode.
LK30	B	Connects the AD7891-2's $\overline{\text{CONVST}}$ pin to the FL0 pin of the edge connector.
LK31	B	MODE pin is connected to V_{DD} and part is configured for its parallel operating mode.

EVALUATION BOARD INTERFACING

Interfacing to the evaluation board is either via a 96-way connector, J1 or a 9-way D-Type connector, J2. J1 is used to connect the evaluation board to the EVAL-CONTROL BOARD. It can also be used for parallel interface connections to the evaluation board when operating the AD7891 in its parallel interface mode without the EVAL-CONTROL BOARD. J2 is used for serial interface connections when operating the AD7891-2 in its serial interface mode. The pinout for the J1 connector is shown in Figure 1 and its pin designations are given in Table II. The pinout for the J2 connector is given in Figure 2 and its corresponding pin designations are given in Table III.

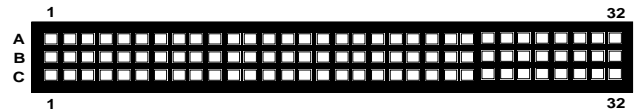

Figure 1. Pin Configuration for the 96-Way Connector, J1

96-Way Connector Pin Description

D0-D11	Data Bit 0 to Data Bit 11. These are three-state TTL-compatible outputs from the AD7891-2. Parallel data from the part is obtained at these pins.
DGND	Digital Ground. These lines are connected to the digital ground plane on the evaluation board. It allows the user to provide the digital supply via the connector along with the other digital signals.
$\overline{\text{RD}}$	Read. This is an active low logic input which is used in conjunction with $\overline{\text{CS}}$ low to enable the data outputs.
$\overline{\text{CS}}$	Chip Select. This is an active low logic input which is used in conjunction with $\overline{\text{RD}}$ low to enable the data outputs and with $\overline{\text{WR}}$ to allow input data to be written to the part.
$\overline{\text{WR}}$	Write Input. This is an active low logic input used in conjunction with $\overline{\text{CS}}$ to latch the multiplexer address and software control information.
FL0	Flag zero. This is a logic input and is connected to the $\overline{\text{CONVST}}$ logic input on the device via LK17. A low to high transition on this input puts the track/hold amplifier into its hold mode and starts a conversion.
$\overline{\text{IRQ2}}$	Interrupt Request 2. This is a logic output and is directly connected to the $\overline{\text{EOC}}$ logic output on the device. This active low logic output indicates the converter status. The end of conversion is signified by a low-going pulse on this line.
AGND	Analog Ground. These lines are connected to the analog ground plane on the evaluation board.
AV_{DD}	Analog +5V Supply. These lines are connected to the V_{DD} supply line on the board.
+12 V	+12 V supply used to power op-amps and voltage reference.
-12 V	-12 V supply used to power op-amps.

EVAL-AD7891-2CB

Table II. 96-Way Connector Pin Functions.

ROW	PIN NO.	MNEMONIC
B	2	D0
B	3	D1
A	4	DGND
B	4	DGND
C	4	DGND
B	5	D2
B	6	D3
B	7	D4
A	9	\overline{RD}
B	9	D5
B	10	D6
C	10	\overline{CS}
B	11	D7
A	12	DGND
B	12	DGND
C	12	DGND
B	13	D8
B	14	D9
B	15	D10
A	16	DGND
B	16	DGND
C	16	DGND
A	17	FL0
B	17	D11
C	17	$\overline{IRQ2}$
A	20	DGND
B	20	DGND
C	20	DGND
A	22	AGND
A	23	AGND
A	24	AGND
A	25	AGND
A	26	AGND
A	29	AGND
B	29	AGND
C	29	AGND
A	31	AV_{SS}
B	31	AV_{SS}
C	31	AV_{SS}
A	32	AV_{DD}
B	32	AV_{DD}
C	32	AV_{DD}

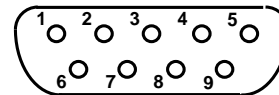

Figure 2. Pin Configuration for D-Type Connector, J2

Table III. J2 Pin Functions

PIN NO.	MNEMONIC
1	SCLK
2	\overline{EOC}
3	\overline{RFS}
4	\overline{TFS}
5	DATA IN
6	DGND
7	DATA OUT
8	V_{DD}
9	$\overline{STANDBY}$

9-Way D-Type Connector Pin Description

- SCLK** Serial Clock Input. When the device is in its serial mode, an external serial clock is applied through this input to obtain serial data from the part.
- \overline{EOC}** End-of-Conversion. This output indicates the status of conversion. A low going pulse on this line signifies the end of a conversion.
- \overline{RFS}** Receive Frame Synchronisation. When the device is in its serial mode, an external \overline{RFS} signal is applied to this input to obtain serial data from the part.
- \overline{TFS}** Transmit Frame Synchronisation. When the part is in serial mode, an external \overline{TFS} signal is applied to this input when serial data is being written to the part
- DATA IN** Serial Data Input. Serial data to the part is applied this input. The serial data should be valid on the falling edge of SCLK for six edges after \overline{TFS} goes low.
- DGND** Digital Ground. This line is connected to the digital ground plane on the evaluation board. It allows the user to provide the digital supply via the connector along with the other digital signals.
- DATA OUT** Serial Data Output. Serial data from the part is obtained at this output. The serial data is clocked out by the rising edge of SCLK and is valid on the falling edge of SCLK for sixteen edges after \overline{RFS} goes low.
- V_{DD}** +5 V Supply. This line is connected to the V_{DD} supply line on the evaluation board. It allows the user to provide the digital supply via the connector along with the other digital signals.
- $\overline{STANDBY}$** Standby Input. When this input is at a logic zero, the AD7891-2 is put into standby mode. Normal operation of the part takes place when $\overline{STANDBY}$ is high.

Note : The remainder of the pins on the 96-way connector are no connects.

SOCKETS

There are ten input sockets relevant to the operation of the AD7891-2 on this evaluation board. The function of these sockets is outlined in Table IV.

Table IV. Socket Functions

Socket	Function
SKT1 - SKT 8	Sub-Minature SMB Socket for $A_{IN1} - A_{IN8}$.
SKT9	Sub-Minature SMB Socket for external reference.
SKT10	Sub-Minature SMB Socket for <u>CONVST</u> input.

CONNECTORS

There are two connectors on the AD7891-2 evaluation board as outlined in Table V.

TABLE V. CONNECTOR FUNCTIONS

Connector	Function
J1	96-Way Connector for Parallel Interface connections.
J2	9-Way D-Type Connector for Serial Interface connections.

OPERATING WITH THE EVAL-CONTROL BOARD

The evaluation board can be operated in a stand-alone mode or operated in conjunction with the EVAL-CONTROL BOARD. This EVAL-CONTROL BOARD is available from Analog Devices under the order entry "EVAL-CONTROL BOARD". When operated with this control board, all supplies and control signals for operating the AD7891-2 are provided by the EVAL-CONTROL BOARD when it is run under control of the AD7891-2 software which is provided with the AD7891-2 evaluation board package. This EVAL-CONTROL BOARD will also operate with all Analog Devices evaluation boards which end with the letters CB in their title.

The 96-way connector on the EVAL-AD7891-2CB plugs directly into the 96-way connector on the EVAL-CONTROL BOARD. The EVAL-CONTROL BOARD is powered from a 12V ac transformer. This is a standard 12V ac 1A transformer. These can also be ordered from Analog Devices under the order entry "EVAL-110VAC-US" for a 110V compatible transformer either "EVAL-220VAC-UK" or "EVAL-220VAC-EU" for a 220V compatible transformer. These transformers are also available for other suppliers including Digikey (110V models) and Campbell Collins (220V models). The EVAL-CONTROL BOARD generates all the required supplies for itself and the EVAL-AD7891-2CB.

Connection between the EVAL-CONTROL BOARD and the serial port of a PC is via a standard RS-232 cable which is provided as part the EVAL-CONTROL BOARD package. Please refer to the manual which accompanies the EVAL-CONTROL BOARD for more details on the EVAL-CONTROL BOARD package.

The CONVST for the EVAL-AD7891-2CB can be provided externally or by the EVAL-CONTROL BOARD. The maximum sampling rate of 500ksp/s is supported when using either source for the CONVST signal.

EVAL-AD7891-2CB

SOFTWARE DESCRIPTION

Included in the EVAL-AD7891-2CB evaluation board package is a PC-compatible disk which contains software for controlling and evaluating the performance of the AD7891-2 when it is operated with the EVAL-CONTROL BOARD. The EVAL-AD7891-2CB Demonstration/Evaluation Software runs under DOS 4.0 or later and requires a minimum of a 386-based machine with 400kB of base RAM and 500kB of free hard disk space. The user interface on the PC is a dedicated program written especially for the AD7891-2.

The disk which accompanies the EVAL-AD7891-2CB contains several files. The user should create a new directory on the main PC drive and label this "AD7891-2". Then, all files on the EVAL-AD7891-2CB disk should be copied into this directory. The Mouse Driver on the PC should be enabled before running the software. If this has not been loaded, the program will not run.

To run the software, simply make the AD7891-2 directory the current directory and type "go". When the evaluation program starts, the user sees the screen shown on Figure 3 (without any FFT or scope waveforms). This is the main screen and it is divided into three parts. The top part provides the main control interface for the AD7891-2 evaluation software. The middle part of the main screen functions as a Digital Storage Oscilloscope and the bottom part of the main screen operates as either a Digital Spectrum Analyzer or a Histogram analyzer.

Each part of the screen has several buttons that can be pressed by using the mouse or the keyboard. To press a button using the mouse, simply use it to move the on-screen pointer to the button to be activated and click. To use the keyboard, simply press the appropriate key as highlighted on the button. Lower case letters must be used. When a button is pressed, it is highlighted on the screen. The next button can be highlighted by using the Tab key or the previous button by holding down the shift key and the Tab key together. The highlighted button can also be pressed by pressing the space bar. Pressing the ESC key halts any operation currently in progress. *In this document, if a button can be activated from the keyboard then the key used is shown in bold in the button name. For example, "no prog" has the "p" highlighted in bold, indicating that the button can be activated by pressing the p key.*

Some buttons have a red indicator. A red indicator on the button means that the function associated with that button is on. Absence of the red indicator light means that the function associated with the button is off. The on/off status of these buttons is changed simply by selecting the button.

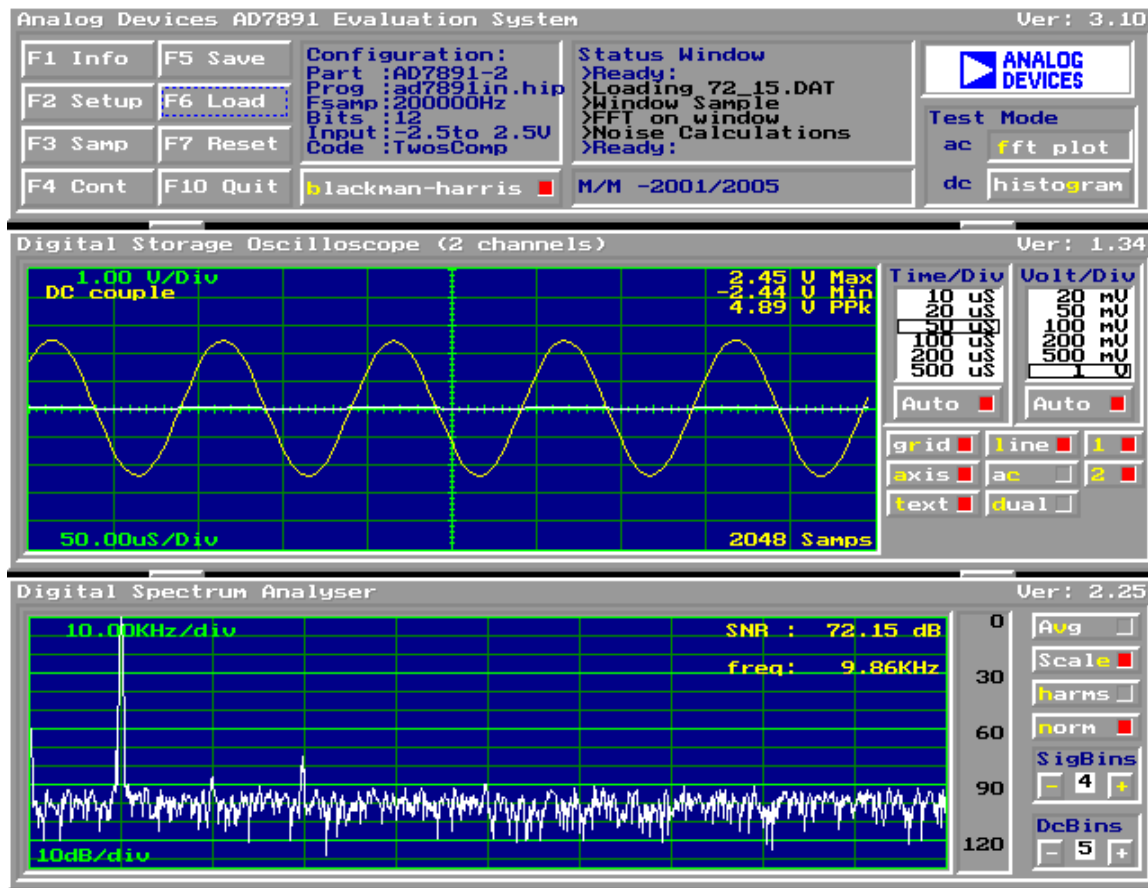

Figure 3. Main Screen

Setting up the EVAL-CONTROL BOARD

When the software is run, the "F2 Setup" button in the top left of the screen should be selected to pop up the setup menu. This menu sets up the EVAL-CONTROL BOARD for use with the EVAL-AD7891-2CB. The Setup Menu is shown in Figure 4.

Firstly, a configuration file must be chosen. The configuration file contains the default configuration information for the EVAL-CONTROL BOARD, the Digital Spectrum Analyzer and the Digital Storage Oscilloscope. It also tells the AD7891-2.EXE software which .HIP file to download to the ADSP-2111. The .HIP file contains the DSP code which is executed by the ADSP-2111. Normally, the "no prog" button is off, so when the configuration file is loaded, the .HIP file is automatically downloaded to the ADSP-2111. However, if the "no prog" button is on, then the .HIP file is not downloaded to the ADSP-2111.

There are two configuration files for the AD7891-2. If an external CONVST pulse is being used, then the configuration file "AD7891EX" must be chosen. The mouse or the keyboard is used to highlight the "AD7891EX" option and the "load device file" button is pressed. The other configuration file option is chosen when using the CONVST signal generated by the EVAL-CONTROL BOARD. The mouse or the keyboard is used to highlight the "AD7891IN" option and, again, the "load device file" button is pressed. See Appendix A for further information about the .CFG files.

After the configuration file is loaded, the sample rate and number of samples can be changed. If the internal CONVST option is in use, then the available CONVST frequencies are limited to frequencies of the form 16 MHz/N, where N is an integer in the range 1 to 65536. If a frequency other than one of these frequencies is chosen, then the EVAL-CONTROL BOARD generates the next lowest available frequency.

The input voltage range and the input voltage offset are shown in the Analog Input "Range" and "Offset". These figures can be altered if required. The input voltage range should be set to 5 V for the ± 2.5 V or 0 to 5V inputs and to 2.5 V for the 0 to 2.5 V input. The offset voltage should be set to the input voltage which causes the ADC to return a code of zero. These figures are used for calculating the Max, Min and PPk (peak to peak) voltage numbers in the oscilloscope window and also for histogram analyzer calculations.

Main Screen

The top left part of the main screen contains eight buttons which are selected using the mouse or by using the function keys from the keyboard. These buttons and the actions they perform are:

- F1:** Info. Activating this button provides information on the software.
- F2:** Setup . Pressing this button pops up the Setup Menu. This menu is described above.
- F3:** Samp. When this key is pressed, the software causes the AD7891-2 to perform a number of conversions as determined by the setup menu (see above). The data from these conversions is then analyzed by the AD7891-2 evaluation software. Another set of samples may be taken by pressing the F3 key again.
- F4:** Cont. Pressing this button causes the software to repeatedly perform conversions and analyze them. Once the conversions and analysis has been done for one set of samples, the software automatically repeats the process. It continues to do this until the ESC key is pressed.



Figure 4. Setup Screen

EVAL-AD7891-2CB

- F5:** Save. This saves a set of samples to a file for use either at a later date or with other software. The samples can be saved either as "volts", "ints" or "binary". The format of all these files is ASCII text. Note that the AD7891 software can only load files saved in the "ints" format. Files saved in the "volts" and "ints" formats can be used with packages such as Mathcad. Files saved in the "binary" format are for viewing purposes only.
- F6:** Load. This allows the user to load data from a file with a .DAT extension. Only data that was saved as ints can be loaded and analyzed. A configuration file must be loaded via the "F2 Setup" menu before the data file can be analyzed. If there is no EVAL-CONTROL BOARD connected to the PC, then the "no prog" button in the "F2 Setup" menu must be on. Once a configuration file has been loaded, the data loaded from the .DAT file is analyzed according to the settings in the "F2 Setup" menu.
- F7:** Reset. Choosing this option resets the EVAL-CONTROL BOARD.
- F10:** Quit. This quits the AD7891-2 evaluation software and returns control to the operating system.

Information Windows

There are three information windows at the top of the main screen. The leftmost window is the configuration window and gives details about part being evaluated. It shows the name of the program which has been downloaded to the EVAL-CONTROL BOARD, the sampling frequency, the number of bits, the analog input range of the part and the output code format of the part. The rightmost large window is the Status window. This window provides feedback to the user as to what operations are currently being performed by the software and also displays error messages. Directly underneath the status window is a small window that shows the maximum and minimum values of the most recently captured samples.

Test Mode

At the top right of the main screen are the Test Mode buttons. These buttons determine what sort of testing is done on the samples captured by the software. Both an ac analysis and dc analysis can be performed. The function of these buttons are:

- fft plot** Choosing this button causes the Digital Spectrum Analyzer to appear at the bottom of the screen.
- histogram:** Choosing this button causes the Histogram Analyzer to be displayed at the bottom of the screen.

There is one other button near the top of the screen, beside the "F10 Quit" button. This is:

- blackman-harris:** When performing a fourier transform of the sampled data, this button determines whether or not the data is windowed by a blackman-harris window before the transform. When this button is on, the data is windowed. When this button is off, the data isn't windowed. See the Digital Spectrum Analyzer section for more details.

Digital Storage Oscilloscope.

When samples of data are captured, they are displayed on the Digital Storage Oscilloscope. If the **blackman-harris** button is turned on then the windowed data is also displayed on the oscilloscope. The 'scope has been designed to act in a similar way as a conventional oscilloscope. To the right of the oscilloscope are several buttons that control the manner in which data is displayed on the 'scope. The timebase for the oscilloscope is automatically chosen by the software if the Time/Div "Auto" button is on. The user can also select the timebase by clicking in the Time/Div window and scrolling up and down through the possible timebases. Similarly, the vertical scale of the oscilloscope is chosen automatically if the Volt/Div "Auto" button is on. The user also has the option of selecting the desired vertical scale in a similar manner to selecting the timebase.

The other buttons associated with the oscilloscope are:

- grid** This button toggles the grid display of the oscilloscope on and off.
- axis** This button toggles the axis display of the oscilloscope on and off
- text** This button toggles the text displayed on the oscilloscope screen on and off.
- line** When the line button is on, the displayed samples are joined together by lines. When this button is off, the samples are displayed as points.
- ac** When this button is on, the dc component of the sampled signal is removed and the signal is displayed. This has the effect of centering the signal vertically on the oscilloscope screen. When this button is on, the dc component is not removed and the signal is displayed with its horizontal axis corresponding to a code of 0. The ac display option is useful for zooming in on a low-level signal that has a large dc offset.
- dual** When the "dual" button is on, the oscilloscope screen is divided into two parts with the sampled data display centered on one horizontal axis and the windowed data display centered on another. When the "dual" button is off, both traces are centered on the same horizontal axis.
- 1** This button toggles the sampled data trace on and off
- 2** This button toggles the windowed data trace on and off.

Histogram Analyzer

The histogram analyzer counts the number of occurrences of each code in the captured samples and displays a histogram of these counts (see Fig. 5). The most frequently occurring code is displayed in the center of the histogram. The analyzer is normally used with a dc input signal and calculates the mean and the standard deviation of the sampled data. The mean and standard deviation are displayed in both volts and in units of the lsb size of the converter. The histogram gives a good indication of the dc noise performance of the ADC. The standard deviation shows directly the noise introduced in the conversion process.

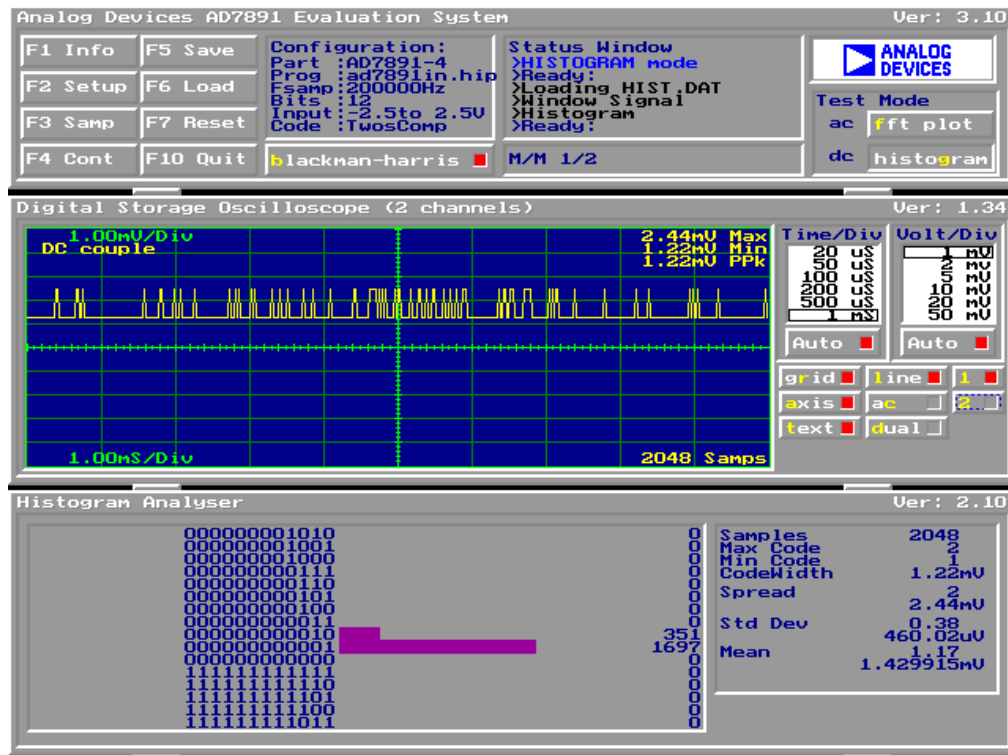

Figure 5. Histogram Screen

Digital Spectrum Analyzer

The Digital Spectrum Analyzer performs a fast fourier transform of the sampled data and displays the magnitude of the results on its screen in decibels (dB). It also calculates the signal to noise ratio of the sampled data, assuming the samples are those of a sine wave. If the "blackman-harris" button near the top of the main screen is on then the data is windowed by a blackman-harris window before the fast fourier transform is performed. Normally, the "blackman-harris" button needs to be on in order to obtain meaningful results from the spectrum analyzer. If the evaluation board is used in a coherent sampling system, ie. one where the conversion start signal applied to the AD7891-2 is synchronized to an input sine wave, in such a way that an integral number of periods of the sine wave are contained in the sampled data, then the blackman-harris window can be turned off.

The buttons to the right of the spectrum analyzer display control the operation of the analyzer. These buttons are:

- Avg** When this button is on, the fourier transforms on each new set of sampled data are averaged so that the noise floor decreases relative to the signal contained in the data.
- Scale** When this button is on, the complete fourier transform from 0 Hz up to fs/2 is displayed in the spectrum analyzer window. When this button is off, the first 510 bins (less for transforms of less than 512 points) of the fourier transform are displayed.
- harms** When this button is on, the harmonics of the input signal are included in the SNR calculation. When this button is off, the harmonics are replaced by average noise in the SNR calculation.

norm When the "norm" button is on, the fourier transformed data is normalized so that the zero dB level is set to the level of the frequency bin with the largest magnitude. The data is displayed on-screen with the largest magnitude bin at the zero dB level. When the "norm" button is off, the data is not normalized. Instead the zero dB level is assigned to the level that the largest magnitude input signal would have and the data is displayed accordingly.

After an FFT has been performed and the frequency spectrum is displayed in the Digital Spectrum Analyser window, the mouse may be used to determine the frequency and dB level of any point in the frequency spectrum. Note that this will only work when one set of samples were taken, it will not work when in the continuous sampling mode. Once the mouse is positioned in the Digital Spectrum Analyser window the cordينات of the mouse in terms of frequency and dBs will be displayed on the right hand side of the window.

When a fourier transform of a windowed sine wave is performed, the power contained in the fundamental frequency is spread out over several frequency bins. To calculate the signal to noise ratio of the signal, the power contained in those frequency bins is summed to give the power of the fundamental. Also, the dc component of the signal is spread over the first few frequency bins. In the SNR calculation, the dc signal must be replaced by the average noise.

The number of frequency bins that are summed to give the power in the fundamental is controlled by the SigBins counter. The range of valid values is 0 to 9. The number contained in the SigBins counter is the number of frequency bins each side of the central peak that are used to calculate the power in the

EVAL-AD7891-2CB

fundamental frequency. The counter is increased by clicking on the SigBins "+" button and decreased by pressing on the SigBins "-" button. As the counter is changed, the SNR is re-calculated and displayed. For a blackman-harris window, the power in the central peak plus the power in four bins each side of the central peak is normally used for SNR calculations. In a coherent sampled data system, all the power from the sine wave is contained in one frequency bin. In such a case the SigBins counter should be set to zero.

The number of low frequency bins that are replaced by average noise in the SNR calculation, is controlled by the DcBins counter. The range of valid values is 0 to 9. The counter is increased by clicking on the DcBins "+" button and decreased by pressing on the DcBins "-" button. As the counter is changed, the SNR is re-calculated and displayed. For a blackman-harris window, the first three to five bins are normally replaced by average noise in the SNR calculation. In a coherent sampled data system, all the dc power is contained in the first frequency bin. In such a case the SigBins counter should be set to one.

APPENDIX A: CONFIGURATION FILE DESCRIPTION

There are two configuration files on the distribution disk that comes with the AD7891-2 evaluation board. They are AD7891IN.CFG, which is used when the EVAL-CONTROL BOARD provides the $\overline{\text{CONVST}}$ signal, and AD7891EX.CFG, which is used when an externally provided $\overline{\text{CONVST}}$ signal is used. They provide initial configuration information to the AD7891-2.EXE program. Normally no changes need to be made to the .CFG files. However sometimes it may be desired to change the initial configuration. This is done by editing the file to make the changes and then saving the changes before running the AD7891-2.EXE program. Here is a listing of the contents of the AD7891IN.CFG file.

```
[DemoController]
Use69=FALSE
AFlags=TRUE
Sports=FALSE
Voltage=5

[EvalBoard]
Part=AD7891-2
Program=ad7891in.hip

NumBits=12

MaxFrequency=600000
DefaultFrequency=200000
DefaultNsamp=256

BinaryCoding=TwosComplement
;BinaryCoding=Binary
;BinaryCoding=DffsetBinary

[AnalogInput]
InputRange=10
InputOffset=0
```

There are three main sections to the configuration file. The name of each section is given in square brackets in the file listing. These sections are [DemoController], [EvalBoard] and [AnalogInput]. Comments are included in the listing by preceding the comment with a semi-colon.

[DemoController] section

This section controls some of the settings of the EVAL-CONTROL BOARD card. **These settings should not be changed.**

[EvalBoard] section

This section tells the AD7891-2.EXE program the name of the part being evaluated, the .HIP program that needs to be downloaded to the ADSP-2111, the number of bits of the ADC, the maximum sampling frequency, the default sampling frequency, the default number of samples to be taken and the form of coding used by the ADC.

The sampling frequencies are in Hertz. There are three valid types of binary coding. These are TwosComplement, Binary and OffsetBinary. Binary and OffsetBinary are interpreted in the same manner in the AD7891-2.EXE program and may be used interchangeably.

[AnalogInput] section

InputRange gives the default voltage range of the input channel. Valid values for InputRange for the AD7891-2 are 5V (for the $\pm 2.5V$ and 0 to 5V ranges) and 2.5 V (for the 0 to 2.5V range). InputOffset is the input voltage that returns a code of zero from the AD7891-2.

COMPONENT LIST

Integrated Circuits

U1-U2	OP467	Quad Op-amp
U3	OP07	Op-amp
U4	AD7891-2	ADC
U5	AD780	2.5 V Reference

Resistors

R1-10	10k Ω Resistor
-------	-----------------------

Links

LK1-31	Shorting Plug
--------	---------------

Capacitors

C2-3, C6, C8-10, C12, C16, C18, C23-24, C26	10 μ F Tantalum Capacitor
C1, C4-5, C&, C11, C13-15, C17, C21-22, C25	0.1 μ F Ceramic Capacitor
C20	10nF Ceramic Capacitor

Sockets

SKT1-10	Sub-Minature BNC Socket
---------	-------------------------

Connectors

J1	9-Way D-Type Connector
J2	96-Way Connector

EVAL-AD7891-2CB

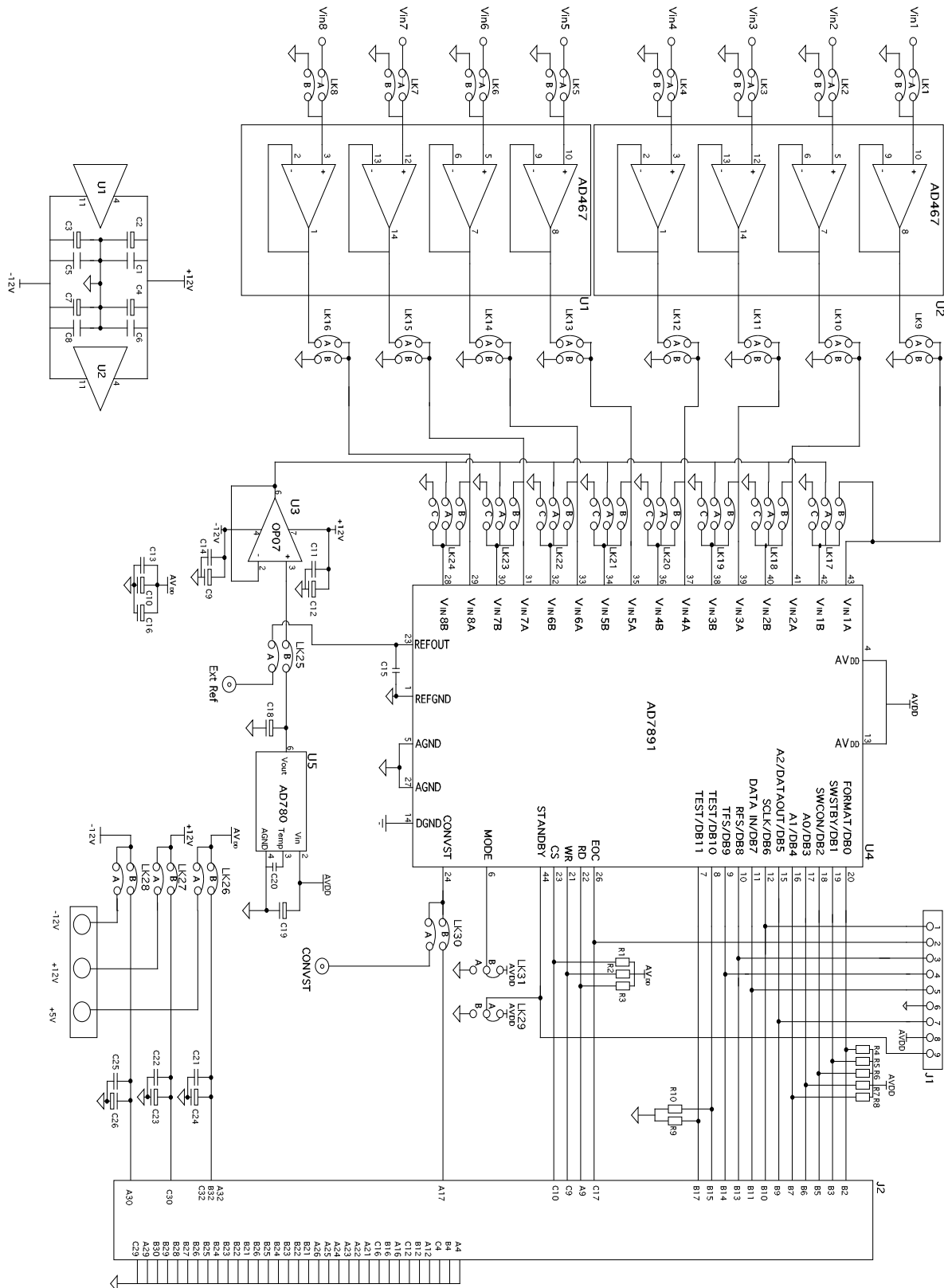

Figure 9. AD7891-2 Evaluation Board Circuit Diagram