

# Pin Selectable Three Phase Power / Energy Metering IC for Stepper Motor / Impulse Counter Applications with Anti Tamper Features



**sames**

## SA2005M

### FEATURES

- Direct drive for electro-mechanical counters or stepper motors
- Selectable dividing ratios for different meter rated conditions
- Per phase energy direction and voltage fail indication
- Precision oscillator on chip

- Meets the IEC 521/1036 Specification requirements for Class 1 AC Watt hour meters
- Operates over a wide temperature range
- Easily adaptable to different signal levels
- Precision voltage reference on chip
- Protected against ESD

### DESCRIPTION

The SAMES SA2005M provides a single chip active energy metering solution for three phase mechanical counter-based meter designs. Very few external components are required and it has direct drive capability for electro-mechanical counters.

The SAMES SA2005M is a CMOS mixed signal integrated circuit that performs three phase power/energy calculations over a range of 1000:1, to an overall accuracy of better than Class 1.

The integrated circuit includes all the required functions for 3-phase power and energy measurement such as oversampling A/D converters for the voltage and current sense inputs, power calculation and energy integration. Internal offsets are eliminated through the use of cancellation procedures.

The SA2005M drives a calibration LED directly. Per phase voltage fail and voltage sequence faults as well as energy direction indication are available as LED outputs. Selectable divider ratios enable various mechanical counter or stepper motor counter resolutions.

A precision oscillator, that replaces an external crystal, is integrated on chip. A voltage reference is integrated on chip.

The SA2005M integrated circuit is available in 24-pin dual in line plastic (DIP-24) and small outline (SOIC-24) package options.

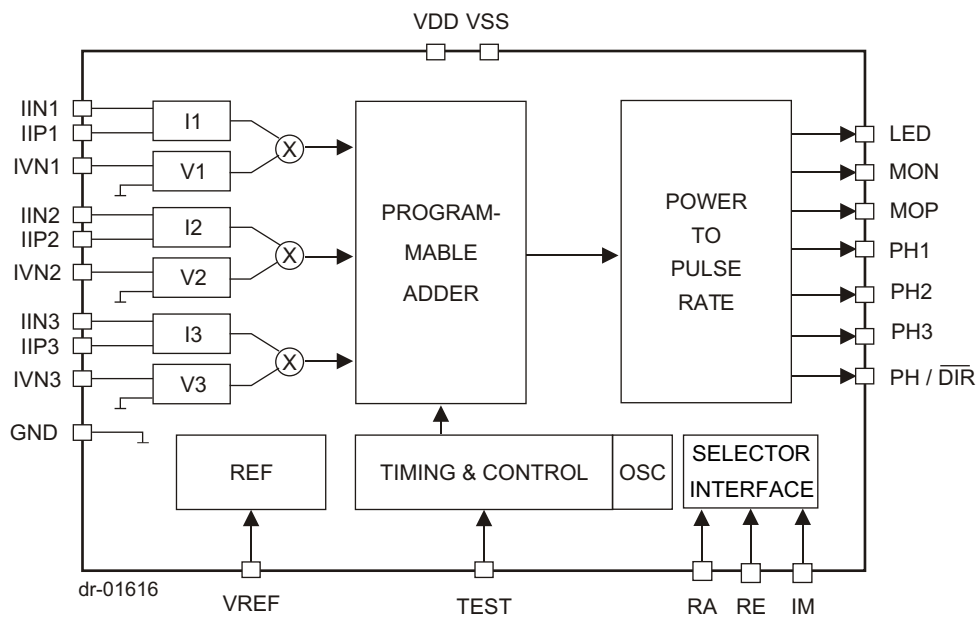

Figure 1: Block diagram

**SA2005M****sames****ELECTRICAL CHARACTERISTICS**(V<sub>DD</sub> = 2.5V, V<sub>SS</sub> = -2.5V, over the temperature range -10°C to +70°C<sup>#</sup>, unless otherwise specified.)

Parameter	Symbol	Min	Typ	Max	Unit	Condition
Operating temp. Range	T <sub>O</sub>	-25		+85	°C	
Supply Voltage: Positive	V <sub>DD</sub>	2.25		2.75	V	
Supply Voltage: Negative	V <sub>SS</sub>	-2.75		-2.25	V	
Supply Current: Positive	I <sub>DD</sub>		15		mA	
Supply Current: Negative	I <sub>SS</sub>		15		mA	
<b>Current Sensor Inputs (Differential)</b>						
Input Current Range	I <sub>II</sub>	-25		+25	µA	Peak value
<b>Voltage Sensor Inputs (Asymmetrical)</b>						
Input Current Range	I <sub>IV</sub>	-25		+25	µA	Peak value
<b>Pin VREF</b>						
Ref. Current	-I <sub>R</sub>	45	50	55	µA	With R = 24k connected to V <sub>SS</sub> Reference to V <sub>SS</sub>
Ref. Voltage	V <sub>R</sub>	1.1		1.3	V	
<b>Digital I/O</b>						
Pin MOP, MON, LED, PH/DIR, PH1, PH2, PH3 Output High Voltage Output Low Voltage	V <sub>OH</sub> V <sub>OL</sub>	V <sub>DD</sub> -1		V <sub>SS</sub> +1	V V	I <sub>OH</sub> = -2mA I <sub>OL</sub> = 5mA
Pins RA, RE, IM, TEST Input Low Voltage Input High Voltage	V <sub>IH</sub> V <sub>IL</sub>	V <sub>DD</sub> -1		V <sub>SS</sub> +1	V V	
Pins RA, RE, IM Pin scan current*	I <sub>IH</sub> -I <sub>IL</sub>	3.1 2		7 4.6	mA mA	V <sub>I</sub> = V <sub>DD</sub> V <sub>I</sub> = V <sub>SS</sub>
Pin TEST Pull down current	I <sub>IH</sub>	48		110	µA	V <sub>I</sub> = V <sub>DD</sub>

#Extended Operating Temperature Range available on request.

\*Switched to pin scan mode for 71µs.

**ABSOLUTE MAXIMUM RATINGS\***

Parameter	Symbol	Min	Max	Unit
Supply Voltage	V <sub>DD</sub> -V <sub>SS</sub>	3.6V	6.0	V
Current on any pin	I <sub>PIN</sub>	-150	+150	mA
Storage Temperature	T <sub>STG</sub>	-40	+125	°C
Operating Temperature	T <sub>O</sub>	-40	+85	°C

\*Stresses above those listed under "Absolute Maximum Ratings" may cause permanent damage to the device. This is a stress rating only. Functional operation of the device at these or any other condition above those indicated in the operational sections of this specification, is not implied. Exposure to Absolute Maximum Ratings for extended periods may affect device reliability.



**PIN DESCRIPTION**

PIN	Designation	Description
20	GND	Analog Ground. The voltage to this pin should be mid-way between $V_{DD}$ and $V_{SS}$ .
6	$V_{DD}$	Positive supply voltage. Typically +5V if a current transformer is used for current sensing.
18	$V_{SS}$	Negative supply voltage. Typically 0V if a current transformer is used for current sensing.
21, 24, 3	IVN1, IVN2, IVN3	Voltage sense inputs. The current into the A/D converter should be set at $14\mu A_{RMS}$ at nominal mains voltage. The voltage sense input saturates at an input current of $\pm 25\mu A$ peak.
23, 22, 2, 1, 5, 4	IIN1, IIP1, IIN2, IIP2, IIN3, IIP3	Inputs for current sensors. The termination resistor voltage from each current transformer is converted to a current of $16\mu A_{RMS}$ at rated conditions. The current sense input saturates at an input current of $\pm 25\mu A$ peak.
19	VREF	This pin provides the connection for the reference current setting resistor. A 24k resistor connected to $V_{SS}$ sets the optimum operating condition.
17	TEST	Test input. For normal operation connect this pin to $V_{SS}$ .
10	LED	Calibration LED output. Refer to section LED Output (LED) for the pulse rate output options.
11, 12	MON, MOP	Motor pulse outputs. These outputs can be used to drive an impulse counter or stepper motor directly.
13	PH / $\overline{DIR}$	Multiplexed Phase or direction driver output.
14, 15, 16	PH1, PH2, PH3	Multiplexed LED drivers for direction and mains fail indication.
7	RA	Rated conditions select input.
8	RE	The RE input selects the calibration LED resolution as well as the summing mode for the programmable adder.
9	IM	The IM inputs selects the counter resolution (Motor drive output).

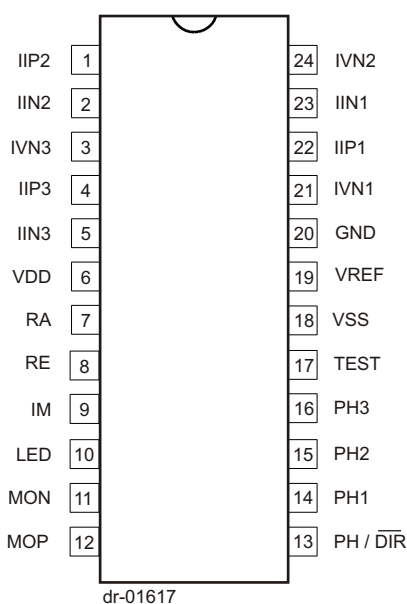
**ORDERING INFORMATION**

Part Number	Package
SA2005MPA	DIP-24
SA2005MSA	SOIC-24

Figure 2: Pin connections: Package: DIP-24, SOIC-24

## FUNCTIONAL DESCRIPTION

The SAMES SA2005M is a CMOS mixed signal analog/digital integrated circuit that performs three phase power/energy calculations across a power range of 1000:1 to an overall accuracy of better than Class 1.

The integrated circuit includes all the required functions for 3-phase power and energy measurement such as oversampling A/D converters for the voltage and current sense inputs, power calculation and energy integration. Internal offsets are eliminated through the use of cancellation procedures.

The integrated circuit includes all the required functions for a three phase mechanical counter-based meter design. A precision oscillator, that replaces an external crystal, is integrated on chip providing a temperature stable time base for the digital circuitry. A temperature stable voltage reference integrated on chip generates the reference current used by the analog circuitry.

Voltage and current are sampled simultaneously by means of a sigma delta modulator type ADC and power is calculated for each individual phase.

The power is fed to a programmable adder that allows the representation of the measured energy to be either total or absolute sum.

The summed power is integrated and divided down to represent integrated energy. Pulses on the LED output and on the mechanical counter driver outputs represent measured amounts of energy. Programmable dividers provide flexible counter as well as calibration LED resolutions.

Outputs for phase fail and voltage sequence faults and energy direction are available.

Calibration of the device is done on the voltage sense inputs of the SA2005M.

The SA2005M may be used in various meter designs by setting the RE, RA and IM pins to the appropriate state. See Input Signals section for the configuration settings. These features enable the meter manufacturer extremely flexible meter designs from a single integrated circuit.

An integrated anti-creep function ensures that no pulses are generated at zero line currents.

## ELECTROSTATIC DISCHARGE (ESD) PROTECTION

The SA2005M integrated circuit's inputs/outputs are protected against ESD.

## POWER CONSUMPTION

The overall power consumption rating of the SA2005M integrated circuit is less than 80mW with a 5V supply.

## INPUT SIGNALS

### ANALOG INPUT CONFIGURATION

The current and voltage sensor inputs are illustrated in figure 3. These inputs are protected against electrostatic discharge through clamping diodes, in conjunction with the amplifiers input configuration. The feedback loops from the outputs of the amplifiers  $A_i$  and  $A_v$  generate virtual shorts on the signal inputs. Exact duplications of the input currents are generated for the analog processing circuitry. The current and voltage sense inputs are identical. Both inputs are differential current driven up to  $\pm 25\mu\text{A}$  peak. One of the voltage sense amplifiers input terminals is internally connected to GND. This configuration is possible because the voltage sense input is much less sensitive to externally induced parasitic signals compared to the current sense inputs.

### Voltage Sense Inputs (IVN1, IVN2, IVN3)

The mains voltages are measured by means of resistor dividers and the divided voltages are converted to currents. The current into each voltage sense input (virtual ground) should be set to  $14\mu\text{A}_{\text{RMS}}$  at rated voltage conditions. The individual mains voltages are divided down to  $14V_{\text{RMS}}$  per phase. The resistors R12, R13 and R14 (figure 8) set the current for the voltage sense inputs. The voltage sense inputs saturate at an input current of  $\pm 25\mu\text{A}$  peak.

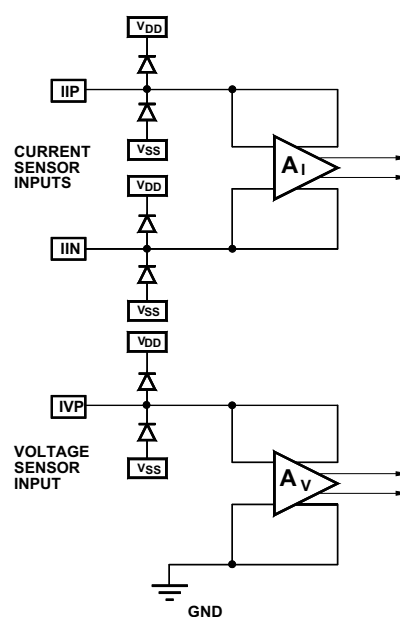

DR-01288

Figure 3: Analog input internal configuration



### Current Sense Inputs (IIN1, IIP1, IIN2, IIP2, IIN3, IIP3)

The current sense inputs connects to a termination resistor connected across the terminals of a current transformer. At rated current the resistor values should be selected for input currents of  $16\mu A_{RMS}$ . Referring to figure 8, the resistors R1 and R2 on current channel 1, resistors R3 and R4 on current channel 2 and resistors R5 and R6 on current channel 3, define the current level into the current sense inputs of the SA2005M. The current sense inputs saturates at an input current of  $\pm 25\mu A$  peak. Resistors R29, R30 and R31 are used as current transformer termination resistors. The voltage drop across the termination resistors should be at least 20mV at rated conditions. Values for the current sense inputs are calculated as follows:

$$R_1 = R_2 = (I_L / 16\mu A_{RMS}) \times R_{29} / 2$$
$$R_3 = R_4 = (I_L / 16\mu A_{RMS}) \times R_{30} / 2$$
$$R_5 = R_6 = (I_L / 16\mu A_{RMS}) \times R_{31} / 2$$

Where:

$$I_L = \text{Line current/CT-ratio}$$

The value of the termination resistors should be less than the resistance of the CT's secondary winding.

### Voltage Reference Connection (VREF)

A bias resistor of 24k provides an optimum bias conditions on chip. Calibration of the SA2005M is done on the voltage sense inputs as described in the Typical Application.

### Rated (RA)

The rated condition select pin allows the metering constants (LED output and Motor Drive output) to remain unchanged for different rated conditions having a 1:2:3 scaling ratio, for example 230V/20A, 230V/40A and 230V/60A. This option allows for the development of different rated meters requiring minimal changes. The only changes to be implemented is the selection of the current sense resistors for the expected rated load currents and the selection of pins RA, RE and IM.

RA Pin	Rated Conditions Multiplying Ratio
VSS	1/3
PH/DIR	2/3
VDD	3/3
Open	Fast LED output. The output is 1252Hz at rated current and voltage inputs.

At a rated condition of 230V/60A (13800W), setting the RA pin to VDD (ratio set to 3/3) and the RE pin to VSS (LED resolution) the LED pulse rate will be 3200 pulses/KWh. With a combination of RA, RE and IM settings various rated condition can easily be met. Refer to the Using the RA, RE, IM inputs section for further information.

### Resolution (RE)

The RE input selects the summing mode for the programmable adder as well as the dividing ratio for the LED output (LED resolution). The following table lists the options available:

RE Pin	Summing Mode	Dividing Ratio (LED Resolution)
VSS	Total sum	1
PH/DIR	Total sum	4
OPEN	Absolute sum	1
VDD	Absolute sum	4

The summing mode is the representation of the measured energy and can be either of the following types:

#### Total sum

This represents the total sum of the energy measured on all three phases flowing through the current sensors. Negative energy flow is taken into consideration.

#### Absolute sum

This represents the sum of the energy measured on all three phases, regardless of the direction of energy flow through the current sensors.

### Impulses (IM)

The IM inputs selects between 1, 10, or 100 dividing ratio for the motor drive outputs (counter resolution). Please note that the device will not perform metering functions while in test mode. Refer to the Using the RA, Re, Im inputs section for further information.

IM Pin	Dividing Ratio (Counter Resolution)
VSS	100 (1P/Kwh)
PH/DIR	10 (10P/Kwh)
VDD	1 (100P/Kwh)
OPEN	Test Mode

### Test Inputs (TEST)

The TEST input is the manufacturers test pin and must be connected to VSS in a metering application.



SA2005M

Using the RA, RE and IM inputs

The following formulas can be used to calculate the LED output and motor pulse rates. Note that for the motor pulse rates shown in the datasheet a MOP pulse followed by a MON pulse is treated as two energy pulses.

LED pulses/kWh = 36.8 x RA x [ (3600 / (Imax x Vnom x 3)) / 1000 ] x (1 / RE)

Where:

- Imax = Meters maximum rated current
Vnom = Meters nominal voltage
RA = 1/3, 2/3 or 3/3 (see Rated RA section)
RE = 1 or 4 (see resolution RE section)

Motor pulses/kWh = 36.8 x RA x [ (3600 / (Imax x Vnom x 3)) / 1000 ] x (1 / ImFactor)

Where:

- Imax = Meters maximum rated current
Vnom = Meters nominal voltage
RA = 1/3, 2/3 or 3/3 (see Rated RA section)
ImFactor depends on IM:
IM = VDD then ImFactor = 16
IM = PH/DIR then ImFactor = 160
IM = VSS then ImFactor = 1600

The following table shows the combinations for some the common rated conditions. IM is selected so that the counter increments to the highest possible rate.

Table with 7 columns: Imax, Vmax, RA, RE, IM, LED Pulse rate (Pulses/kWh), Motor Pulse Rate (Pulses/kWh). Rows include combinations like (10, 230, PH/DIR, PH/DIR or VDD, VDD, 3200, 800).

ANTI-TAMPER CONDITIONS

The SA2005M caters for the following meter tamper conditions, which are indicated as follows:

Table with 3 columns: Method, Description, Result. Rows include Phase Voltages, Phase Failure, no voltage, Phase Sequence Error, Input / Output Terminals Interchanged, Missing Neutral Connection, Return through Earth, Load Imbalance.



### OUTPUT SIGNALS

#### LED Output (LED)

Various LED output pulse rates are available. Refer to the "Using the RA, RE and IM inputs" section. With RA pin open the LED output is 1252Hz at rated conditions. In this mode  $t_{LED}$  is 71uS, for the other pulse rate options  $t_{LED}$  is 10ms. The LED output is active low as shown in figure 4.

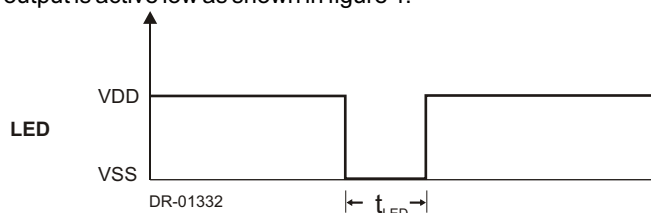

Figure 4: LED pulse output

An integrated anti-creep function prevents any output pulses if the measured power is less than 0.01% of the meters rated current.

#### Motor Output (MOP, MON)

The motor pulse width is fixed at 142ms. The MON pulse will follow the MOP pulse within double the pulse width time. This prevents the motor armature is in the wrong position after a power failure. Both MOP and MON outputs are active high. A low voltage stepper may be driven directly from the device by connecting it between the MOP and MON pins, alternatively an impulse counter may be driven directly by connecting it between MOP and V<sub>SS</sub>. The motor drive waveforms are shown in figure 5.

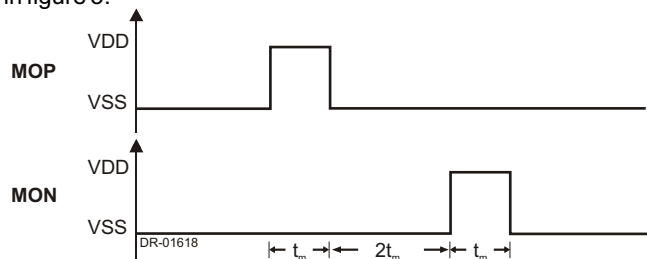

Figure 5: Motor drive on MON and MOP pins of device

#### Multiplex Output (PH/DIR)

The PH/DIR output enables either direction or voltage information on the phase LED driver outputs (PH1, PH2 and PH3). This multiplex output switches between logic 0 and 1 at a frequency of approximately 113Hz. A logic 0 enables energy direction information on the LED driver outputs and a logic 1 enables voltage information.

The PH/DIR output is used in conjunction with the LED driver outputs to display information about each individual phase, see figure 6.

#### Phase LED Drivers (PH1, PH2, PH3)

The LED driver outputs present either direction information or voltage information. The three LED driver outputs are used in conjunction with the PH/DIR output to display information about each individual phase (refer to figure 6) as follows:

##### PH/DIR = 0 (Direction indication)

When PH/DIR is low (logic 0) energy direction information for each individual phase is available on PH1, PH2 and PH3. A logic 1 indicates reverse energy flow and a logic 0 indicates positive energy flow. Reverse energy flow is defined as the condition where the voltage sense input and the current sense inputs are out of phase (greater than 90 degrees). Positive energy flow is defined as the condition where the voltage sense and current sense inputs are in phase.

##### PH/DIR = 1 (Voltage fail / phase sequence error)

When PH/DIR is high (logic 1) voltage information is available on PH1, PH2 and PH3. A logic 1 on any of these pins indicates a voltage failure, the SA2005M does not detect a zero crossing on the applicable voltage sense input. Referring to figure 6 the voltage fail LED will be on when the voltage phase is present and off when the voltage phase is missing.

In the case of a phase sequence error all three LED driver outputs PH1, PH2 and PH3 will pulse with a repetition rate of approximately 1Hz.

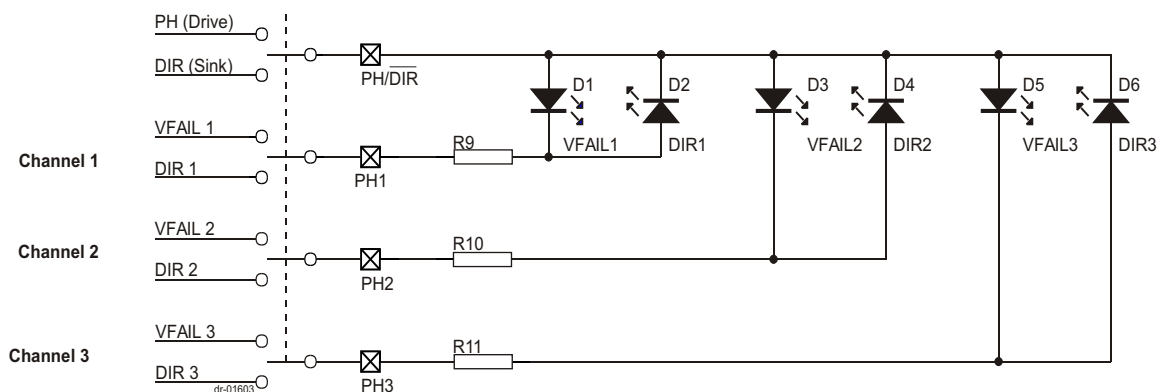

Figure 6: Multiplexing of the LED Drivers



## TYPICAL APPLICATION

The analog (metering) interface described in this section is designed for measuring 230V/60A with precision better than Class 1.

The most important external components for the SA2005M integrated circuit are the current sense resistors, the voltage sense resistors and the bias setting resistor. The resistors used in the metering section should be of the same type so temperature effects are minimized.

### Current Input IIN1, IIP1, IIN2, IIP2

Two current transformers are used to measure the current in the live and neutral phases. The output of the current transformer is terminated with a low impedance resistor. The voltage drop across the termination resistor is converted to a current that is fed to the differential current inputs of the SA2005M.

### CT Termination Resistor

The voltage drop across the CT termination resistor at rated current should be at least 20mV. The CTs have low phase shift and a ratio of 1:2500. The CT is terminated with a 3.6 resistor giving a voltage drop of 86.4mV across the termination resistor at rated conditions ( $I_{max}$  for the meter).

### Current Sensor Input Resistors

The resistors R1 and R2 define the current level into the current sense inputs of phase one of the SA2005M. The resistor values are selected for an input current of 16μA on the current inputs of the SA2005M at rated conditions. For a 60A meter at 2500:1 CT the resistor values are calculated as follows:

$$\begin{aligned} R1 = R2 &= (I_L / 16\mu A) \times R_{SH} / 2 \\ &= 60A / 2500 / 16\mu A \times 3.6 / 2 \\ &= 2.7k \end{aligned}$$

$I_L$  = Line current

RSH = CT Termination resistor

2500 = CT ratio

The three current channels are identical so R1 = R2 = R3 = R4=R5=R6.

### Voltage Input IVP

The voltage input of the SA2005M (IVP) is driven with a current of 14μA at nominal mains voltage. This voltage input saturates at approximately 17μA. At a nominal voltage current of 14μA allows for 20% overdriving. The mains voltage is divided with a voltage divider to 14V that is fed to the voltage input pins via a 1M resistor.

### Voltage Divider

The voltage divider for phase one is calculated for a voltage drop of 14V. Equations for the voltage divider in figure 4 are:

$$R_B = R_{20} + R_{23} + R_{26}$$

$$R_B = R_{12} \parallel (R_{17} + P1)$$

A 5k trimpot will be used in the voltage channel for meter calibration. The center position on the pot is used in the calibration P1 = 2.5k .

Combining the two equations gives:

$$(R_A + R_B) / 230V = R_B / 14V$$

Values for resistors R17 = 22k , P1 = 2.5k and R12 = 1M is chosen.

Substituting the values result in:

$$R_B = 23.914k$$

$$R_A = R_B \times (230V / 14V - 1)$$

$$R_A = 368.96k .$$

Standard resistor values for R24, R25 and R26 are chosen to be 130k

Standard resistor values for R18, R19, R20, R21, R22 and R23 are chosen to be 120k

The capacitor C1 is used to compensate for phase shift between the voltage sense inputs and the current sense inputs of the device, in cases where CTs with phase errors are used. The phase shift caused by the CT may be corrected by inserting a capacitor in the voltage divider circuit. To compensate for a phase shift of 0.18 degrees the capacitor value is calculated as follows:

$$C = 1 / (2 \times \text{Mains frequency} \times R_{12} \times \tan(\text{Phase shift angle}))$$

$$C = 1 / (2 \times 50 \times 1M \times \tan(0.18 \text{ degrees}))$$

$$C = 1.013\mu F$$

### Reference Voltage Bias resistor

R7 defines all on chip and reference currents. With R7 = 24k optimum conditions are set. Device calibration is done on the voltage input of the device.

### Device setup

The resistor values calculated above is for a 60A rated meter so RA must be set to VDD, according to the description under Input Signals. The RE and IM inputs of the device must be set to the appropriate states for the meter to function correctly.



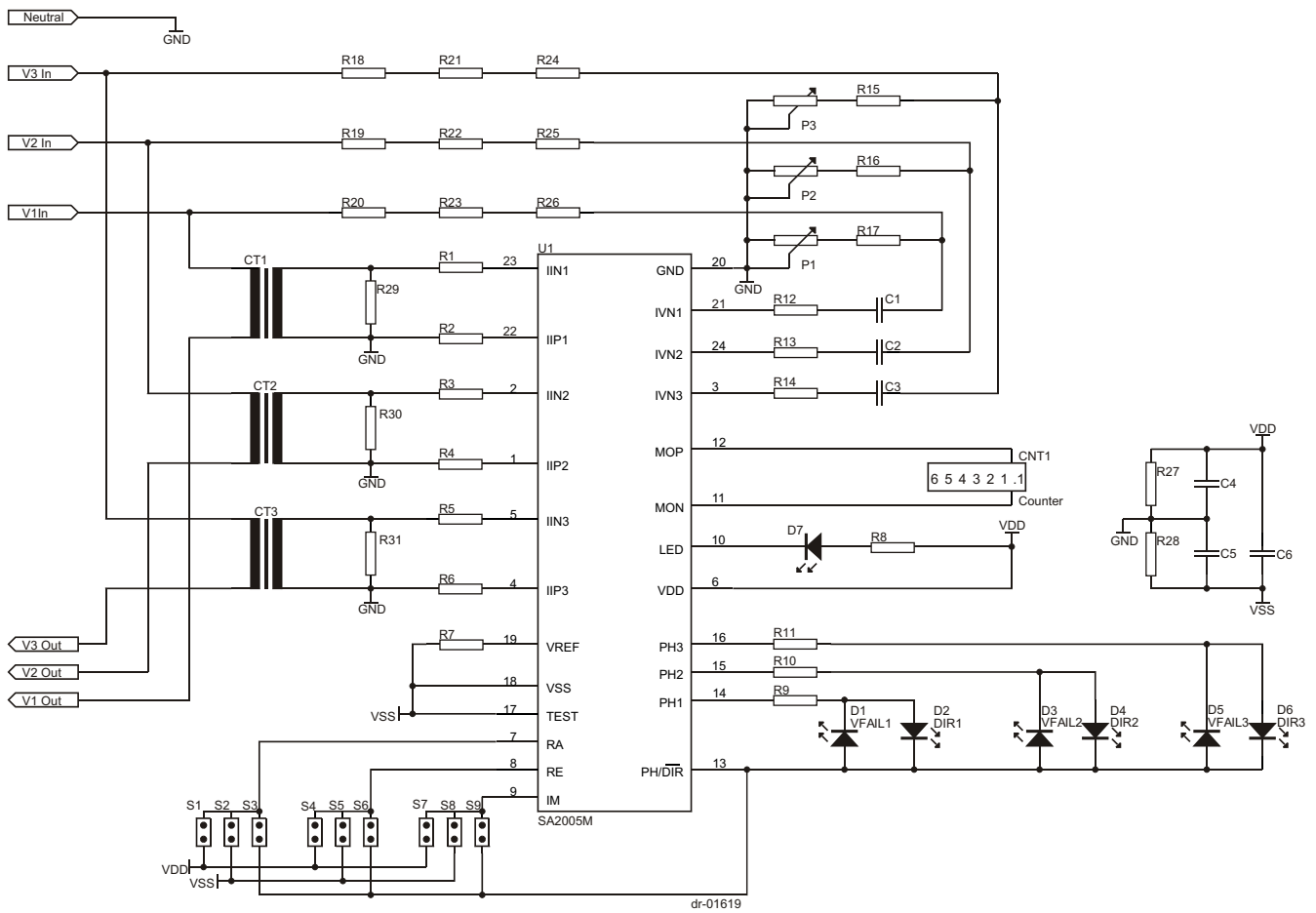

Figure 8: Typical application circuit

**SA2005M****Parts List for Application Circuit: Figure 8**

Symbol	Description	Detail
U1	SA2005M	DIP-24 / SOIC-24
R1	Resistor, 2.7k, 1/4W, 1%, metal	Note 1
R2	Resistor, 2.7k, 1/4W, 1%, metal	Note 1
R3	Resistor, 2.7k, 1/4W, 1%, metal	Note 1
R4	Resistor, 2.7k, 1/4W, 1%, metal	Note 1
R5	Resistor, 2.7k, 1/4W, 1%, metal	Note 1
R6	Resistor, 2.7k, 1/4W, 1%, metal	Note 1
R7	Resistor, 24k, 1/4W, 1%, metal	
R8	Resistor, 1k, 1/4W, 5%, carbon	
R9	Resistor, 1k, 1/4W, 5%, carbon	
R10	Resistor, 1k, 1/4W, 5%, carbon	
R11	Resistor, 1k, 1/4W, 5%, carbon	
R12	Resistor, 1M, 1/4W, 1%, metal	
R13	Resistor, 1M, 1/4W, 1%, metal	
R14	Resistor, 1M, 1/4W, 1%, metal	
R15	Resistor, 22k, 1/4W, 1%, metal	
R16	Resistor, 22k, 1/4W, 1%, metal	
R17	Resistor, 22k, 1/4W, 1%, metal	
R18	Resistor, 120k, 1/4W, 1%, metal	
R19	Resistor, 120k, 1/4W, 1%, metal	
R20	Resistor, 120k, 1/4W, 1%, metal	
R21	Resistor, 120k, 1/4W, 1%, metal	
R22	Resistor, 120k, 1/4W, 1%, metal	
R23	Resistor, 120k, 1/4W, 1%, metal	
R24	Resistor, 130k, 1/4W, 1%, metal	
R25	Resistor, 130k, 1/4W, 1%, metal	
R26	Resistor, 130k, 1/4W, 1%, metal	
R27	Resistor, 1k, 1/4W, 1%, metal	
R28	Resistor, 1k, 1/4W, 1%, metal	
R29	Resistor, 3.6 , 1/4W, 1%, metal	Note 1
R30	Resistor, 3.6 , 1/4W, 1%, metal	Note 1
R31	Resistor, 3.6 , 1/4W, 1%, metal	Note 1
C1	Capacitor, 1 $\mu$ F, 16V, electrolytic	Note 2
C2	Capacitor, 1 $\mu$ F, 16V, electrolytic	Note 2
C3	Capacitor, 1 $\mu$ F, 16V, electrolytic	Note 2
C4	Capacitor, 220nF	
C5	Capacitor, 220nF	
C6	Capacitor, 820nF	Note 3
D1	3mm Light emitting diode	Direction indicator
D2	3mm Light emitting diode	V1 Fail indicator
D3	3mm Light emitting diode	Direction indicator
D4	3mm Light emitting diode	V2 Fail indicator
D5	3mm Light emitting diode	Direction indicator
D6	3mm Light emitting diode	V3 Fail indicator
D7	3 mm Light emitting diode	Calibration LED
CNT1	Mechanical stepper motor counter	
CT1	Current Transformer, TZ76	2500:1
CT2	Current Transformer, TZ76	2500:1
CT3	Current Transformer, TZ76	2500:1

**Note 1:** Resistor (R1 to R6) values are dependent on the selection of the termination resistors (R29 to R31) and CT combination

**Note 2:** Capacitor values may be selected to compensate for phase errors caused by the current transformers.

**Note 3:** Capacitor C6 to be positioned as close as possible to supply pins  $V_{DD}$  and  $V_{SS}$  of U1 as possible.



sames

SA2005M

NOTES:

**DISCLAIMER:**

The information contained in this document is confidential and proprietary to South African Micro-Electronic Systems (Pty) Ltd ("SAMES") and may not be copied or disclosed to a third party, in whole or in part, without the express written consent of SAMES. The information contained herein is current as of the date of publication; however, delivery of this document shall not under any circumstances create any implication that the information contained herein is correct as of any time subsequent to such date. SAMES does not undertake to inform any recipient of this document of any changes in the information contained herein, and SAMES expressly reserves the right to make changes in such information, without notification, even if such changes would render information contained herein inaccurate or incomplete. SAMES makes no representation or warranty that any circuit designed by reference to the information contained herein, will function without errors and as intended by the designer.

Any sales or technical questions may be posted to our e-mail address below:  
**[energy@sames.co.za](mailto:energy@sames.co.za)**

For the latest updates on datasheets, please visit our web site:  
**<http://www.sames.co.za>**.

**SOUTH AFRICAN MICRO-ELECTRONIC SYSTEMS (PTY) LTD**

**Tel:** (012) 333-6021  
**Tel: Int** +27 12 333-6021  
**Fax:** (012) 333-8071  
**Fax: Int** +27 12 333-8071

**P O BOX 15888  
33 ELAND STREET  
LYNN EAST 0039  
REPUBLIC OF SOUTH AFRICA**

**33 ELAND STREET  
KOEDOESPOORT INDUSTRIAL AREA  
PRETORIA  
REPUBLIC OF SOUTH AFRICA**