

Features and Benefits

- Absolute Integrated Pressure sensor
- Less than 1% error range overall
- Programmable through the connector (3 pins)
- Trimmable offset and sensitivity
- Ratiometric output
- Rail-to-Rail output
- Output proportional to the applied pressure
- Diagnostics of broken supply wires and broken sensor
- Output protected against short-circuits at both battery terminals
- On-chip Signal Conditioning (single die solution)
- Different pressure ranges available

Application Examples

- Automotive applications (MAP, T-MAP, HVAC, ...)
- Industrial applications
- Barometric Air Pressure

Ordering Information

Part No.	Temperature Suffix	Package Code	Option	Description
MLX90808	L (-40 °C to 150 °C)	UF (die on foil)	- 2	3 to 7 Bar Pressure Span

1 Functional Diagram

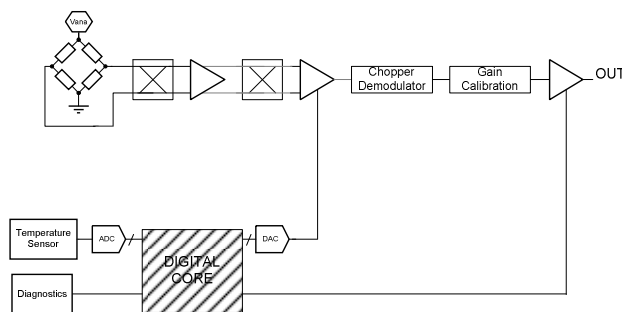

2 General Description

The MLX90808 is an integrated absolute pressure sensor realised in CMOS technology. It consists of an analog signal chain that interacts with the digital core and on-chip temperature sensor in order to provide uniform overall sensing characteristics after calibration and to cancel the temperature related parameter drifts. The output is proportional to the applied pressure with an adjustable slope and offset. The chip is ratiometric and goes rail-to-rail with a 1mA source and sink capability.

Table of Contents

1 Functional Diagram	1
2 General Description	1
3 Absolute Maximum Ratings	3
4 General Electrical Specifications	3
5 Diagnostic features	4
6 Detailed General Description	4
7 Unique Features	5
8 Application Information	5
9 Programming and Calibration	6
9.1 Programming of the Temporary Memory of 90808	6
9.2 Zapping of the 90808	7
10 Disclaimer	8

3 Absolute Maximum Ratings

Parameter	Symbol	Min Value	Max Value	Units
Supply Voltage (overvoltage)	V _{DD}	-14	16	V
Supply Voltage (operating)	V _{DD}	4.5	5.5	V
Supply Current, I _{DD} with V _{DD} = 16 V	I _{DD}		25	mA
Output Voltage, V _{out}	V _{out}	-0.5	16	V
Supply current with output shorted to 0V .. 16V	I _{DD}		100	mA
Supply Current limit, reverse polarity	I _{DD}		160	mA
Programming Temperature Range (ZAP cells)	T _P	-20	100	°C
Operating Temperature Range	T _A	-40	140	°C
Storage Temperature Range	T _S	- 50	150	°C
ESD Sensitivity (AEC Q100 002)		-2	2	kV

Table 1: Absolute maximum ratings

Exceeding the absolute maximum ratings may cause permanent damage. Exposure to absolute-maximum-rated conditions for extended periods may affect device reliability.

4 General Electrical Specifications

DC Operating Parameters T_A = -40 °C to 140 °C, V_{DD} = 5V (unless otherwise specified)

Parameter	Symbol	Test Conditions	Min	Typ	Max	Units
Supply Voltage	V _{dd}	Operating	4.5	5	5.5	V
Supply Current	I _{dd}	V _{dd} = 5 V ± 10% , excluding output current	4	7	10	mA
Output Current Capability	I _{out}	V _{dd} = 5 V	1			mA
output @ low pressure	V _{out}	V _{dd} = 5 V	0.46	0.5	0.54	V
output @ full scale pressure	V _{out}	V _{dd} = 5 V	4.46	4.5	4.54	V
Low Clamping level	V _{out}		6.5		8.5	% V _{od}
High Clamping level	V _{out}		91		93.5	% V _{od}
Linearity error	V _{out}		-0.5		0.5	% V _{od}
Ratiometricity error	V _{out}		-0.3		0.3	% V _{od}
Programming Supply	V _{cc prog}		10		10.5	V
Zapping Supply	V _{zap}		15.5		16	V
Zapping Temperature	T _{zap}		- 20		100	°C
Lifetime			15			Year
Power-up time		T = 0 °C ... 85 °C		3.5		ms
Power-up time		T < 0 °C or T > 85 °C		5		ms
Response time 0% / 63%	T _{rp}			1		ms
Response time 10% / 90%	T _{rp 10 - 90}			1.5		ms
Stabilization time	T _s			3		ms
Pressure accuracy					1	% FS

Table 2: Electrical specifications

5 Diagnostic features

DC Operating Parameters $T_A = -40^{\circ}\text{C}$ to 140°C , $V_{DD} = 5\text{ V}$ (unless otherwise specified)

Parameter	Symbol	Test Conditions	Min	Typ	Max	Units
Output when sensor is broken		Sensor broken			2	% V_{dd}
Output when V_{dd} is broken		Pull up > 4k7			4	% V_{dd}
Output when V_{dd} is broken		Pull down			0	% V_{dd}
Output when V_{ss} is broken		Pull down > 10k Ω	96			% V_{dd}
Output when V_{ss} is broken		Pull up	100			% V_{dd}

Table 3: Diagnostic features

6 Detailed General Description

This chip integrates a pressure sensor and the associated signal conditioning on the same die. The supply voltage V_{DD} directly supplies the pressure sensor.

The pressure sensing element consists of a square diaphragm realized in the silicon chip by backside etching. Due to its small thickness this diaphragm reacts to a pressure difference at both of its side by cambering. The internal strain increases, in particular at the border of the diaphragm. Here, the piezo-resistive elements have been implanted into the silicon diaphragm, which act as transducer.

The piezo-resistive elements react to pressure induced changes of strain by changes in their resistance. Four resistors are placed at all four borders of the square diaphragm. They are arranged in a Wheatstone-bridge.

A chopped instrumentation stage amplifies the differential output signal of the sensor. The gain of this amplifier can be adjusted with 3 bits. After the input stage, there is a 3 bit programmable coarse offset which is followed by a differential to single-ended conversion. The reference voltage for this stage is generated by a 10 bit DAC and varies linearly with temperature in order to perform the offset and offset drift compensation. A digital hardware multiplier calculates this compensation. The temperature signal, serving as input for this multiplier, is generated from the ADC of the output signal of the internal temperature sensor.

The chopped signal is demodulated with a switched capacitor stage. The buffered output serves as reference for a 10 bit DAC to perform the span and span drift compensation. The DAC is controlled by the digital part.

Finally the signal is given out by a class AB rail-to-rail amplifier capable of sourcing and sinking large currents.

A 3-point temperature and 2-point pressure calibration is required (room temperature, a low temperature and a high temperature), to achieve an error less than $\pm 1\%$ over the complete pressure and temperature range (the output error is referred to the output span).

PTC (Programming Through Connector) protocol is used to perform calibration. The programming of the sensor chip is carried out via the analog connections (i.e. supply, ground, signal out). No additional pins are necessary for calibration.

The output circuit is protected against short circuit to GND, V_{bat} (16V) and V_{dd} .

7 Unique Features

Diagnostic Limits

Diagnostic of broken sensor: The output will be forced to ground (or a very low level) when the sensor membrane breaks.

Diagnostic of broken wires: The output will be forced to ground (or a very low level) when the supply wire breaks, even when a pull-up is still connected to the output pin.

The output will be forced to the supply voltage (or a very high level) when the ground wire breaks, even when a pull-down is still connected to the output pin.

Output Protection

The output is protected against short-circuits at either battery terminals. The output can handle voltages between -0.5V and 16V (independent of supply voltage).

Memlock Function

The memory consists of ZAP cells. When all calibration parameters are programmed, the chip can be locked. This to avoid unwanted that data be written into the memory cells.

Once the chip is locked in a normal application, we can not read the zap contents and it is not possible to unlock afterwards, unless the MOW pin is used. This can be done by apply a supply between 2.5V and 3.5V on the MOW pin, then we can read back the content of the memory cells and zap another cell if necessary.

Clamping Levels

The user can enable the clamping of the output to ensure that the output can not enter the fault band in normal application.

8 Application Information

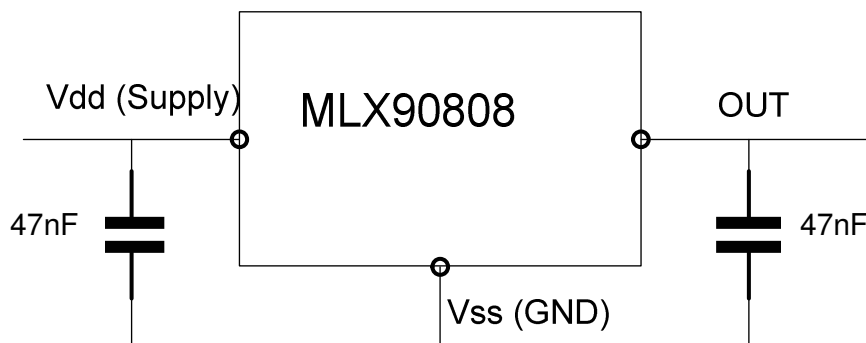

Very few off-chip components are needed (only 2 decoupling capacitors, not higher than 100 nF). Only 3 pins are used (Vdd, Vss, Out), see pad layout drawing in paragraph 9. Calibration and Programming is made through the OUT pin.

9 Programming and Calibration

9.1 Programming of the Temporary Memory of 90808

The temporary memory consists of a shift register of flip flops. It is used to search for the correct calibration settings. Mode 1 (TC[5:0]=01h) is used for this purpose. Afterwards these settings can be put in the permanent memory. The programming is done through the connector: you only need the application pins (supply, ground and output). You can enable the programming by forcing the supply high enough (VCC_T). You can input the data through the OUT pin. The data is Pulse Width modulated. At the end of the programming, we keep OUT high until VCC has reached his normal level (VCC_N). Thereafter we disconnect OUT. It is not necessary to do a power-down before the next settings are programmed.

Timings

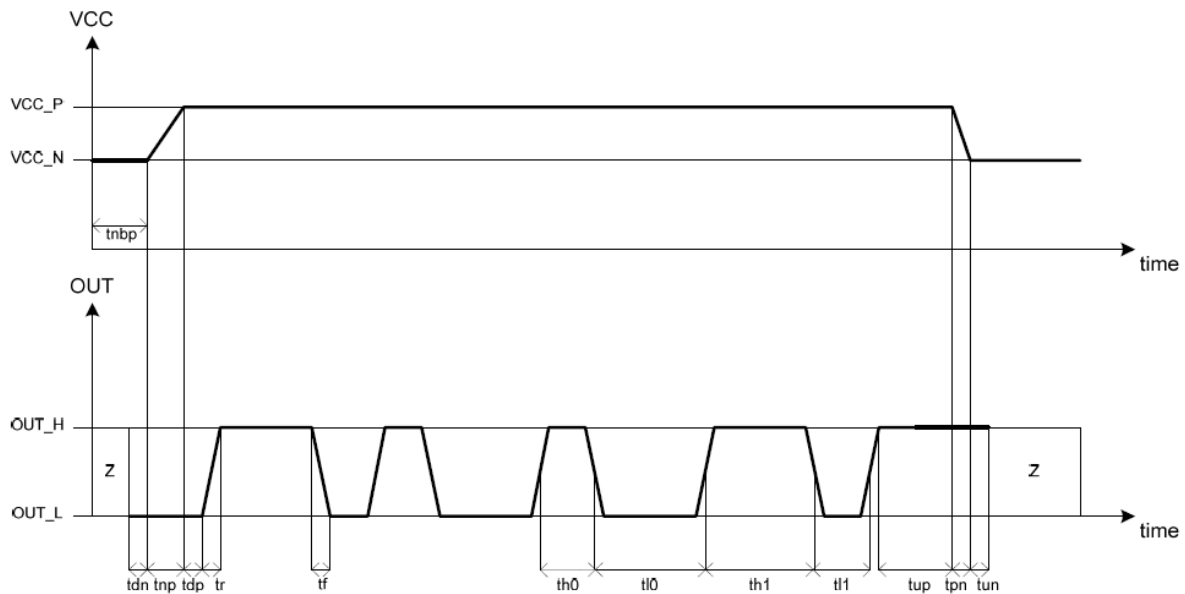

9.2 Zapping of the 90808

The permanent memory of the 90808 is built with zap cells. The data output of an unprogrammed zap cell is 0. The data output is 1 when the cell is zapped. It is not possible to reprogram a zap cell to 0. Only 1 bit can be zapped at a time.

You should use the normal mode (TC[5:0]=00h) and program 1 bit to '1' in the temporary memory. Afterwards you need to increase the supply voltage (VCC_Z) to be able to zap the bit. The zapping starts when OUT goes high (OUT_Z). There will flow a high current of approximately 200mA during the zapping. The memlock-bit should be zapped as last bit, because it disables the programming.

The zap cells can also be read out by using mode 5 (TC[5:0]=05h). One bit should be set to 1 in the temporary memory. The supply current should be measured at the normal supply voltage. A low current (ICC_R0) indicates that the zap cell is not programmed. A high current (ICC_R1) indicates that the zap cell is programmed.

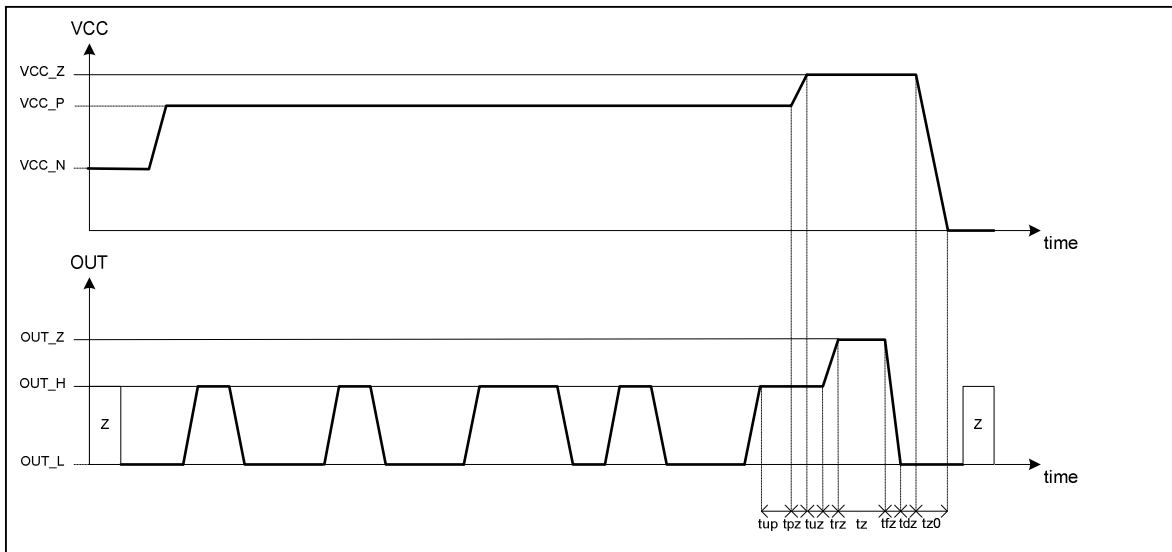

10 Disclaimer

Devices sold by Melexis are covered by the warranty and patent indemnification provisions appearing in its Term of Sale. Melexis makes no warranty, express, statutory, implied, or by description regarding the information set forth herein or regarding the freedom of the described devices from patent infringement. Melexis reserves the right to change specifications and prices at any time and without notice. Therefore, prior to designing this product into a system, it is necessary to check with Melexis for current information. This product is intended for use in normal commercial applications. Applications requiring extended temperature range, unusual environmental requirements, or high reliability applications, such as military, medical life-support or life-sustaining equipment are specifically not recommended without additional processing by Melexis for each application.

The information furnished by Melexis is believed to be correct and accurate. However, Melexis shall not be liable to recipient or any third party for any damages, including but not limited to personal injury, property damage, loss of profits, loss of use, interrupt of business or indirect, special incidental or consequential damages, of any kind, in connection with or arising out of the furnishing, performance or use of the technical data herein. No obligation or liability to recipient or any third party shall arise or flow out of Melexis' rendering of technical or other services.

© 2005 Melexis NV. All rights reserved.

For the latest version of this document, go to our website at
www.melexis.com

Or for additional information contact Melexis Direct:

Europe, Africa, Asia:
Phone: +32 1367 0495
E-mail: sales_europe@melexis.com

America:
Phone: +1 603 223 2362
E-mail: sales_usa@melexis.com

ISO/TS 16949 and ISO14001 Certified