150mA ULTRA LOW SUPPLY CURRENT LDO REGULATOR

NO.EA-150-070727

OUTLINE

The RP104x Series are CMOS-based voltage regulator ICs with high output voltage accuracy, extremely low supply current and low ON-resistance. Each of these ICs consists of a voltage reference unit, an error amplifier, resistor-net for voltage setting, a current limit circuit and a chip enable circuit.

These ICs perform with ultra low supply current (Typ.1.0 μ A), which prolong the battery life.

Since the packages for these ICs are PLP1010-4, SOT-23-5 and SC-82AB, therefore high density mounting of the ICs on boards is possible.

FEATURES

- Supply Current Typ. 1.0 μ A
(Except the current through CE pull down circuit)
- Standby Current Typ. 0.1 μ A
- Dropout Voltage..... Typ. 0.24V ($I_{OUT}=150\text{mA}$, $V_{OUT}=2.8\text{V}$)
- Temperature-Drift Coefficient of Output Voltage Typ. $\pm 40\text{ppm}/^\circ\text{C}$
- Line Regulation Typ. 0.02%/V
- Output Voltage Accuracy $\pm 0.8\%$
- Packages..... PLP1010-4, SOT-23-5, SC-82AB
- Output Voltage..... 1.2V, 1.3V, 1.5V, 1.8V, 1.85V, 1.9V, 2.0V, 2.5V
2.6V, 2.7V, 2.8V, 2.85V, 2.9V, 3.0V, 3.2V, 3.3V
- Built-in Fold Back Protection Circuit..... Typ. 40mA (Current at short mode)
- Ceramic capacitors are recommended to be used with this IC 0.1 μ F or more

APPLICATIONS

- Power source for portable communication equipment.
- Power source for electrical appliances such as cameras, VCRs and camcorders.
- Power source for battery-powered equipment.

BLOCK DIAGRAMS

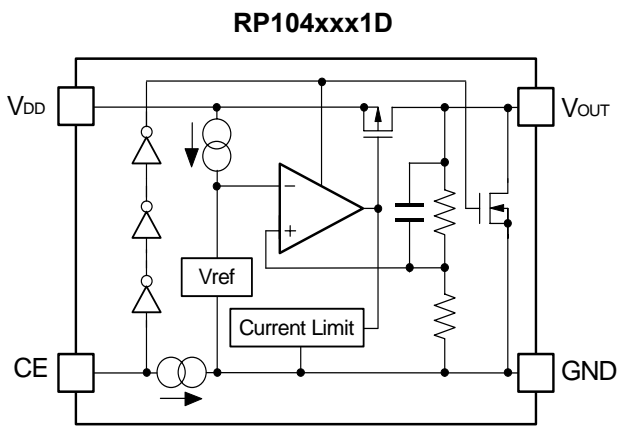
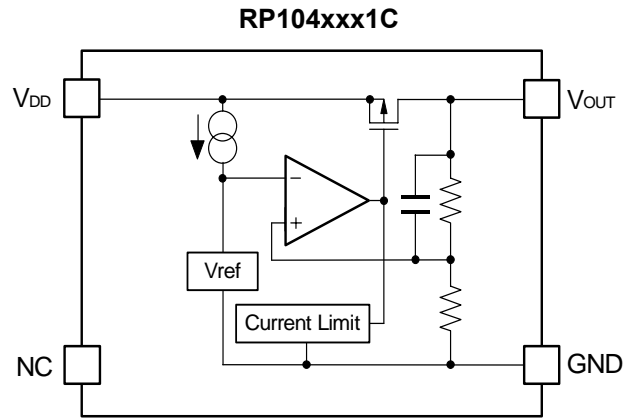
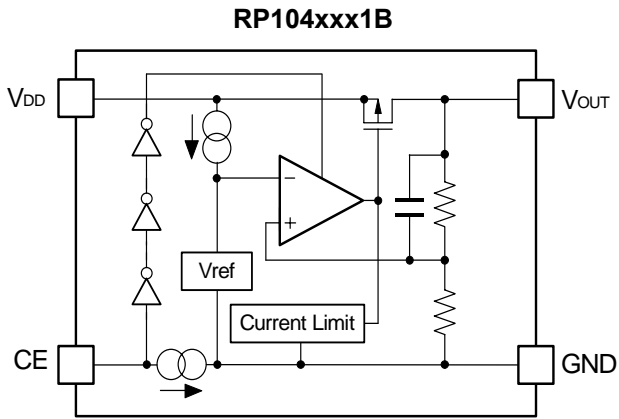

SELECTION GUIDE

The output voltage, chip enable circuit, auto discharge function*, and the taping type for the ICs can be selected at the user's request.

The selection can be made with designating the part number as shown below;

RP104xxx1x-xx-x ←Part Number
 ↑ ↑ ↑ ↑ ↑
 a b c d e

Code	Contents
a	Designation of Package Type: K: PLP1010-4 N: SOT-23-5 Q: SC-82AB
b	Setting Output Voltage (V _{OUT}): The following 16 kinds of voltage are standard. 1.2V, 1.3V, 1.5V, 1.8V, 1.85V, 1.9V, 2.0V, 2.5V, 2.6V, 2.7V, 2.8V, 2.85V, 2.9V, 3.0V, 3.2V, 3.3V Exceptions: 1.85V=RP104x181x5-xx-x, 2.85V=RP104x281x5-xx-x
c	Designation of Mask Option B: active high, without auto discharge function* at OFF state. C: without chip enable circuit. D: active high, with auto discharge function* at OFF state.
d	Designation of Taping Type: Ex. TR (refer to Taping Specifications; TR type is the standard direction.)
e	Designation of composition of pin plating: -F: Lead free plating (SOT-23-5, SC-82AB) None: Au plating (PLP1010-4)

*) When the mode is into standby with CE signal, auto discharge transistor turns on, and it makes the turn-off speed faster than normal type.

PIN CONFIGURATIONS

• PLP1010-4

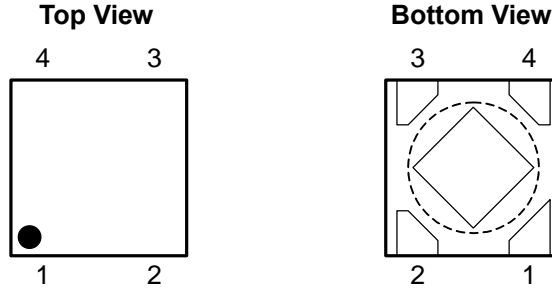

• SOT-23-5

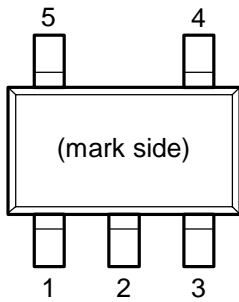

• SC-82AB

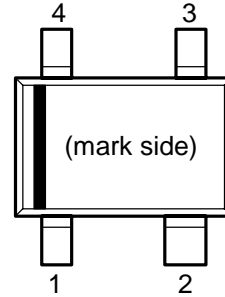

PIN DESCRIPTIONS

• PLP1010-4*

Pin No.	Symbol	Description
1	V _{OUT}	Output Pin
2	GND	Ground Pin
3	CE / NC	Chip Enable Pin ("H" Active) or No Connection
4	V _{DD}	Input Pin

*) Tab in the  parts have GND level.
 (They are connected to the back side of this IC.)
 Do not connect to other wires or land patterns.

• SOT-23-5

Pin No.	Symbol	Description
1	V _{DD}	Input Pin
2	GND	Ground Pin
3	CE / NC	Chip Enable Pin ("H" Active) or No Connection
4	NC	No Connection
5	V _{OUT}	Output Pin

• SC-82AB

Pin No.	Symbol	Description
1	CE / NC	Chip Enable Pin ("H" Active) or No Connection
2	GND	Ground Pin
3	V _{OUT}	Output Pin
4	V _{DD}	Input Pin

ABSOLUTE MAXIMUM RATINGS

Symbol	Item	Rating	Unit
V_{IN}	Input Voltage	6.0	V
V_{CE}	Input Voltage (CE Pin)	6.0	V
V_{OUT}	Output Voltage	-0.3 to $V_{IN}+0.3$	V
I_{OUT}	Output Current	200	mA
P_D	Power Dissipation (PLP1010-4)*	400	mW
	Power Dissipation (SOT-23-5)*	420	
	Power Dissipation (SC-82AB)*	380	
T_{opt}	Operating Temperature Range	-40 to 85	°C
T_{stg}	Storage Temperature Range	-55 to 125	°C

*) For Power Dissipation, please refer to PACKAGE INFORMATION to be described.

ELECTRICAL CHARACTERISTICS

● RP104xxx1B/C/D

V_{IN} =Set $V_{OUT}+1V$ for V_{OUT} options greater than 1.5V. $V_{IN}=2.5V$ for $V_{OUT} \leq 1.5V$.

$I_{OUT}=1mA$, $C_{IN}=C_{OUT}=0.1\mu F$, unless otherwise noted.

 values indicate $-40^{\circ}C \leq T_{opt} \leq 85^{\circ}C$, unless otherwise noted.

$T_{opt}=25^{\circ}C$

Symbol	Item	Conditions	Min.	Typ.	Max.	Unit	
V_{OUT}	Output Voltage	$T_{opt}=25^{\circ}C$	$V_{OUT} > 2.0V$	$\times 0.992$		$\times 1.008$	V
			$V_{OUT} \leq 2.0V$	-16		+16	mV
		$-40^{\circ}C \leq T_{opt} \leq 85^{\circ}C$	$V_{OUT} > 2.0V$	$\times 0.985$		$\times 1.015$	V
			$V_{OUT} \leq 2.0V$	-30		+30	mV
I_{OUT}	Output Current		150			mA	
$\frac{\Delta V_{OUT}}{\Delta I_{OUT}}$	Load Regulation	$1mA \leq I_{OUT} \leq 150mA$		10	20	mV	
V_{DIF}	Dropout Voltage	$I_{OUT}=150mA$	$1.2V \leq V_{OUT} < 1.5V$		0.76	1.05	V
			$1.5V \leq V_{OUT} < 1.7V$		0.53	0.80	
			$1.7V \leq V_{OUT} < 2.0V$		0.44	0.65	
			$2.0V \leq V_{OUT} < 2.5V$		0.34	0.50	
			$2.5V \leq V_{OUT} < 2.8V$		0.28	0.40	
			$2.8V \leq V_{OUT} \leq 3.3V$		0.24	0.32	
I_{SS}	Supply Current	$I_{OUT}=0mA$		1.0	1.5	μA	
$I_{standby}$	Standby Current	$V_{CE}=0V$		0.1	1.0	μA	
$\frac{\Delta V_{OUT}}{\Delta V_{IN}}$	Line Regulation	Set $V_{OUT}+0.5V \leq V_{IN} \leq 5.0V$		0.02	0.10	%/V	
V_{IN}	Input Voltage*		1.7		5.25	V	
$\frac{\Delta V_{OUT}}{\Delta T_{opt}}$	Output Voltage Temperature Coefficient	$-40^{\circ}C \leq T_{opt} \leq 85^{\circ}C$		± 40		ppm/ $^{\circ}C$	
I_{lim}	Short Current Limit	$V_{OUT}=0V$		40		mA	
I_{PD}	CE Pull-down Current			0.3		μA	
V_{CEH}	CE Input Voltage "H"		1.5			V	
V_{CEL}	CE Input Voltage "L"				0.3	V	
R_{LOW}	Low Output Nch Tr. ON Resistance (of D version)	$V_{IN}=4.0V$ $V_{CE}=0V$		30		Ω	

*) When Input Voltage is 5.5V, the total operational time must be within 500hrs.

TYPICAL APPLICATION

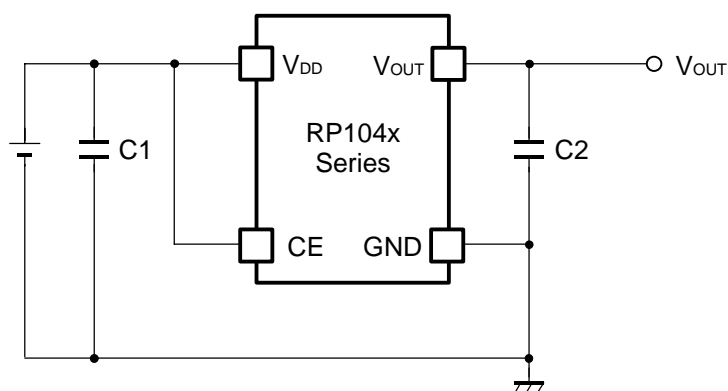

(External Components)

C2 0.1 μ F MURATA: GRM155B31C104KA87B

TECHNICAL NOTES

When using these ICs, consider the following points:

Phase Compensation

In these ICs, phase compensation is made for securing stable operation even if the load current is varied. For this purpose, use a capacitor C2 with good frequency characteristics and ESR (Equivalent Series Resistance). (Note: If additional ceramic capacitors are connected with parallel to the output pin with an output capacitor for phase compensation, the operation might be unstable. Because of this, test these ICs with as same external components as ones to be used on the PCB.)

PCB Layout

Make V_{DD} and GND lines sufficient. If their impedance is high, noise pickup or unstable operation may result. Connect a capacitor C1 with a capacitance value as much as 0.1 μ F or more between V_{DD} and GND pin, and as close as possible to the pins.

Set external components, especially the output capacitor C2, as close as possible to the ICs, and make wiring as short as possible.

TEST CIRCUITS

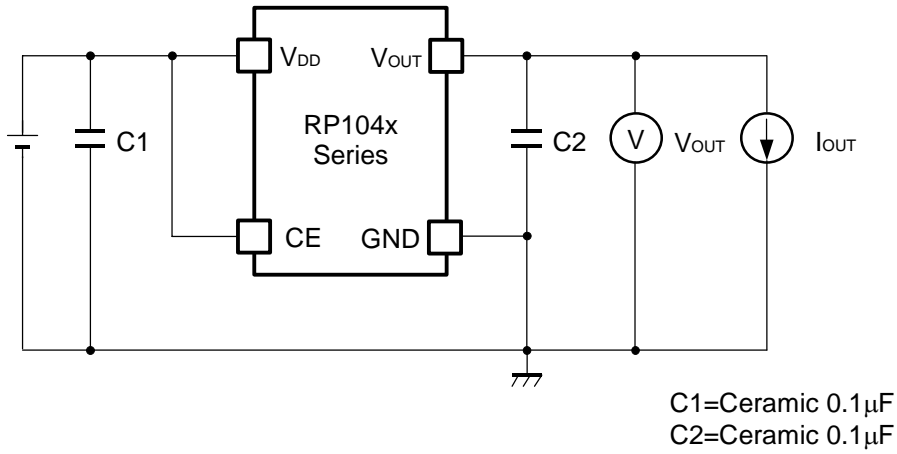

Basic Test Circuit

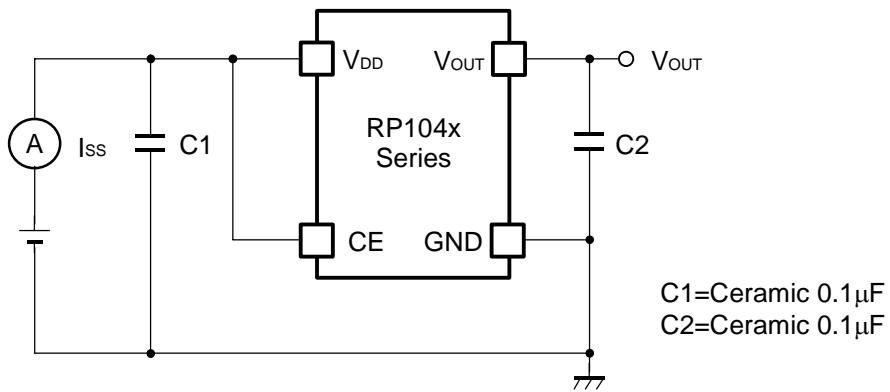

Test Circuit for Supply Current

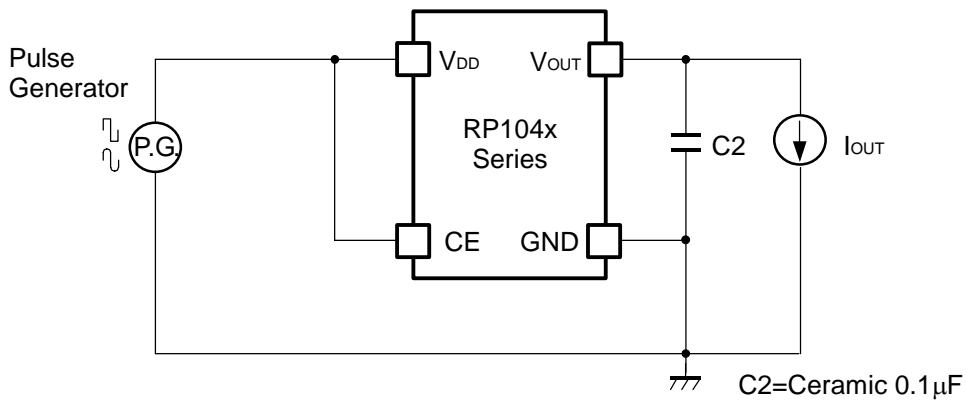

Test Circuit for Ripple Rejection

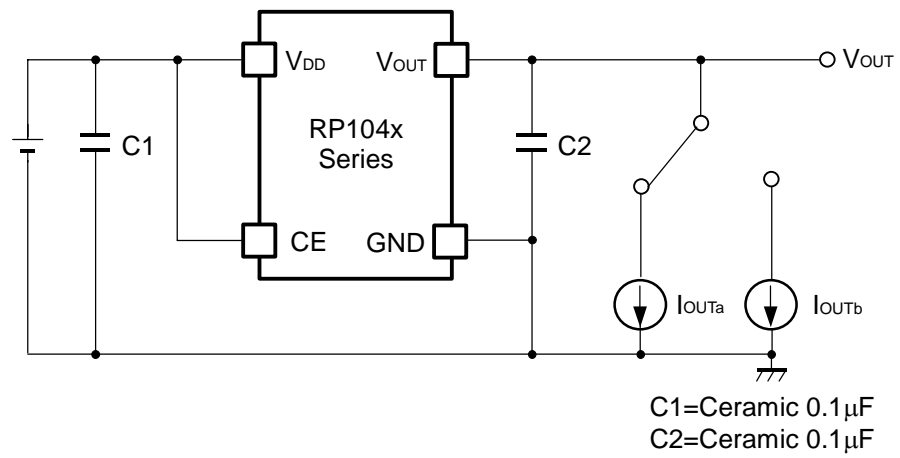

Test Circuit for Load Transient Response

TYPICAL CHARACTERISTICS

1) Output Voltage vs. Output Current (C1=Ceramic 0.1 μ F, C2=Ceramic 0.1 μ F, T_{opt}=25°C)

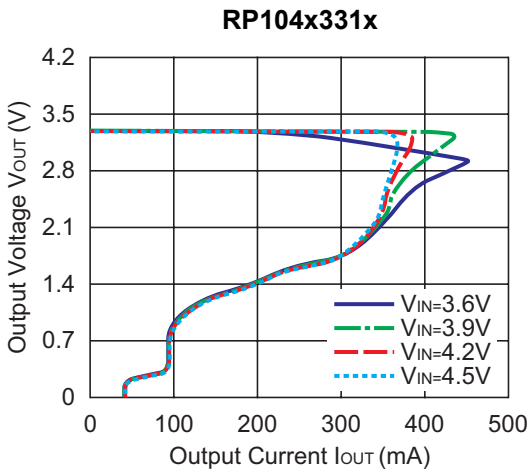
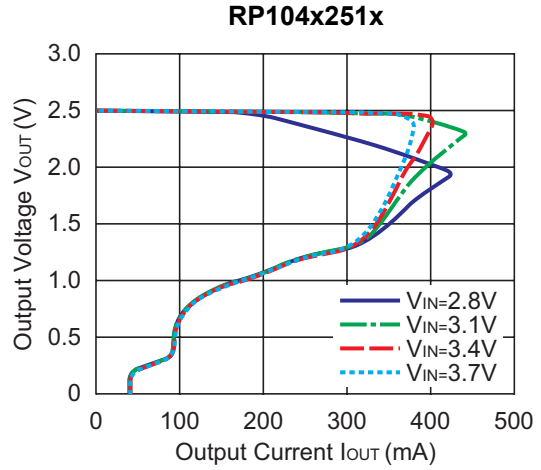
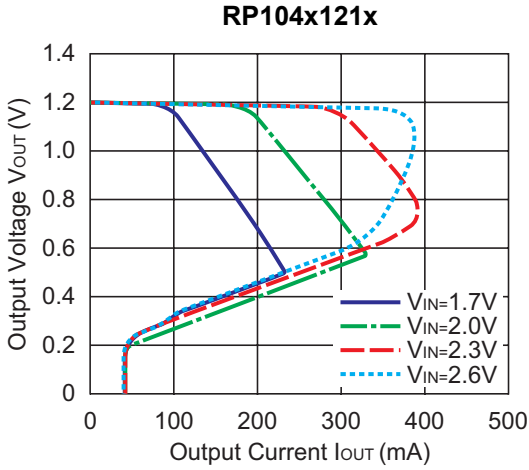

2) Output Voltage vs. Input Voltage (C1=Ceramic 0.1 μ F, C2=Ceramic 0.1 μ F, T_{opt}=25°C)

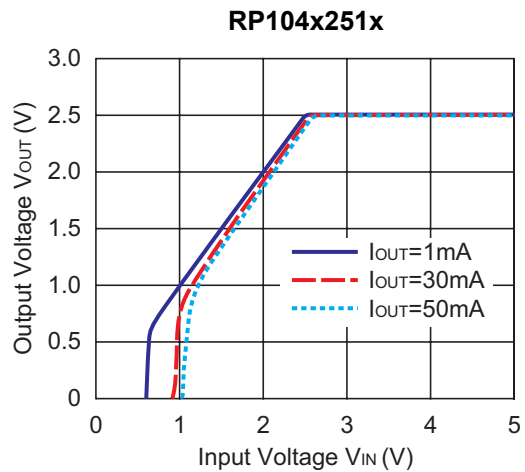
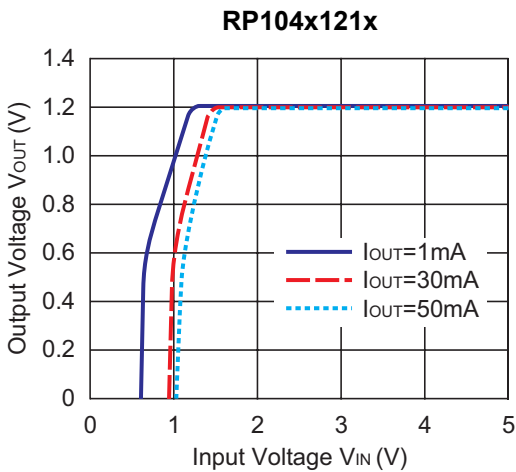

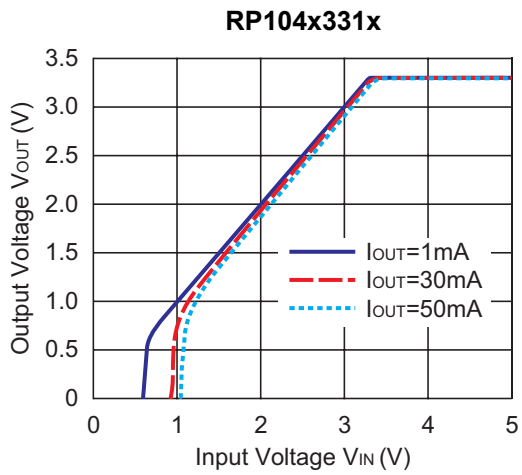

3) Supply Current vs. Input Voltage (C1=Ceramic 0.1 μ F, C2=Ceramic 0.1 μ F, T_{opt}=25°C)

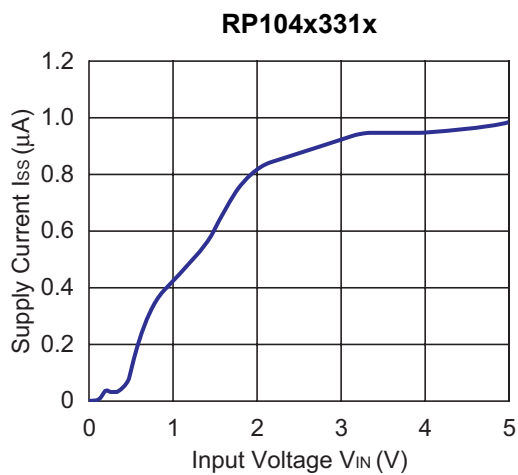
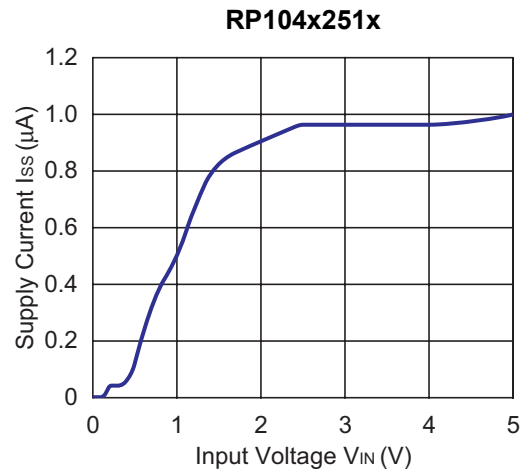
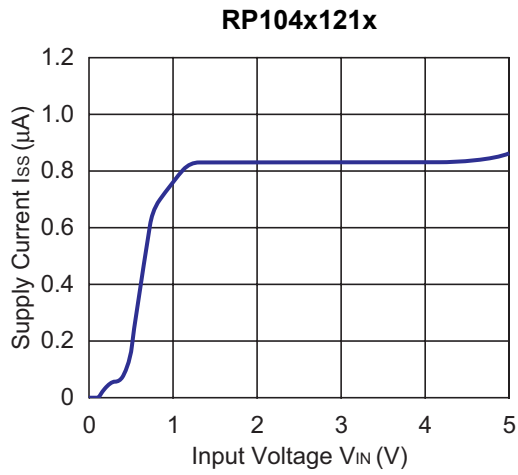

RP104x

4) Output Voltage vs. Temperature (C1=Ceramic 0.1 μ F, C2=Ceramic 0.1 μ F, I_{OUT}=1mA)

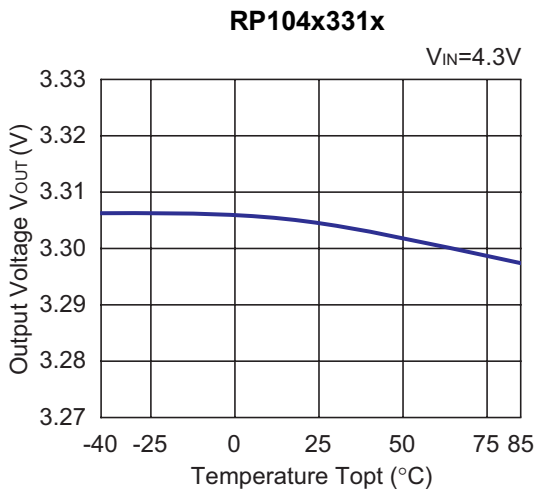
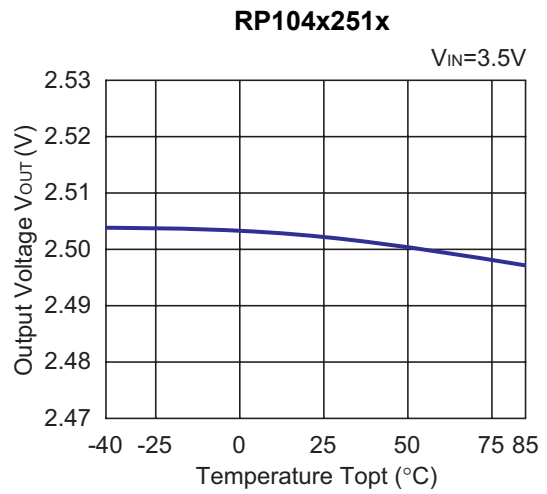
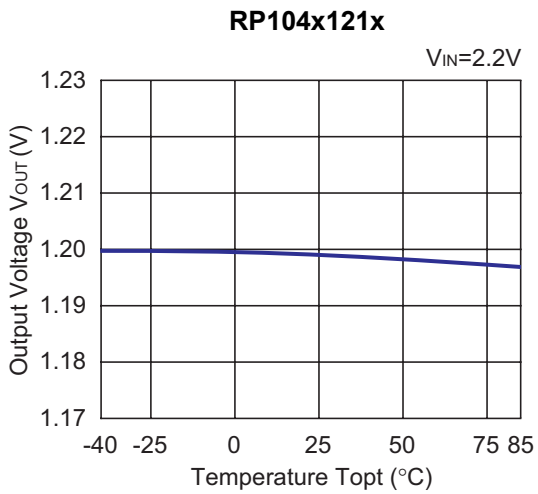

5) Supply Current vs. Temperature (C1=Ceramic 0.1 μ F, C2=Ceramic 0.1 μ F)

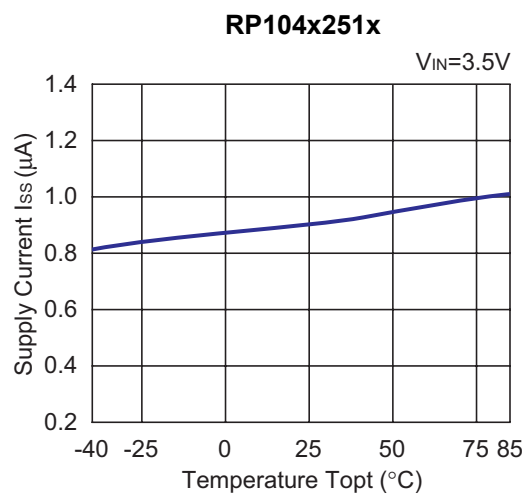
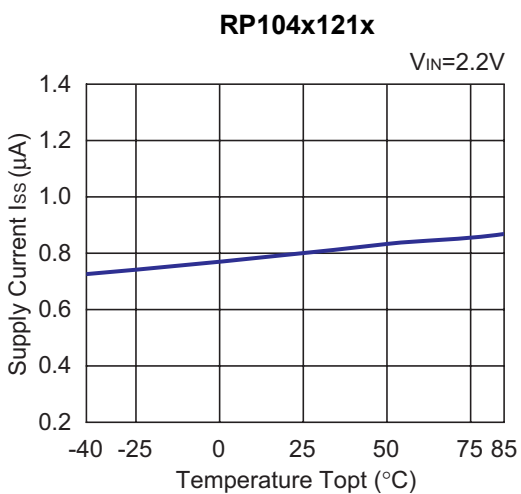

RP104x331x

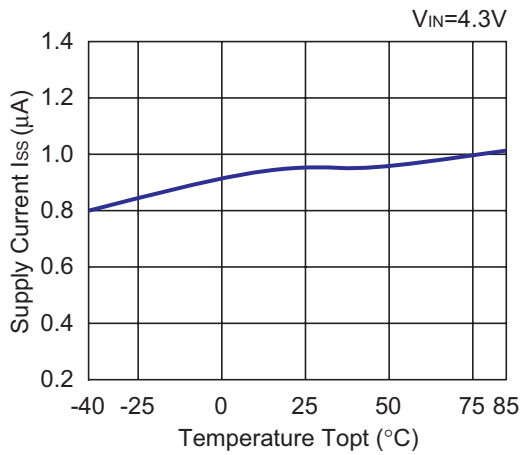

6) Dropout Voltage vs. Output Current (C1=Ceramic 0.1µF, C2=Ceramic 0.1µF, $T_{opt}=25^{\circ}C$)

RP104x121x

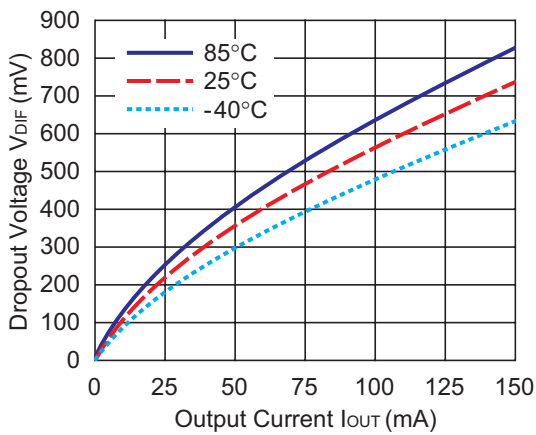

RP104x251x

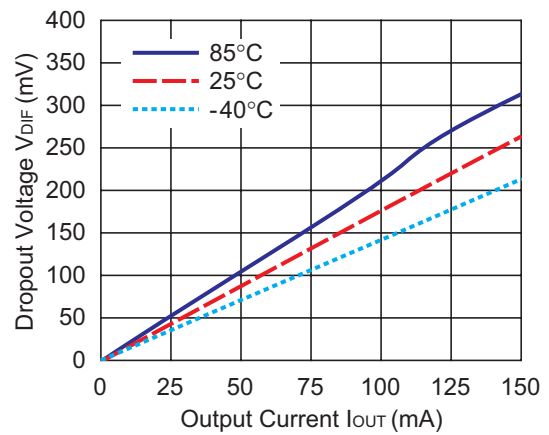

RP104x331x

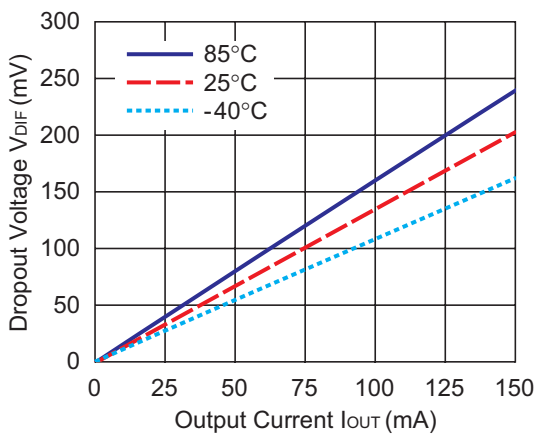

7) Dropout Voltage vs. Set Output Voltage (C1=Ceramic 0.1 μ F, C2=Ceramic 0.1 μ F, T_{opt}=25°C)

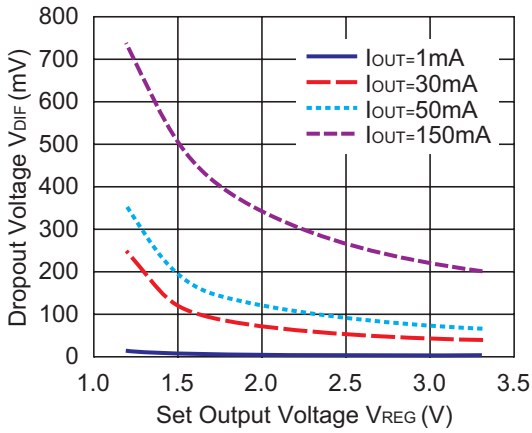

8) Ripple Rejection vs. Input Bias Voltage (C1=none, C2=Ceramic 0.1 μ F, T_{opt}=25°C)

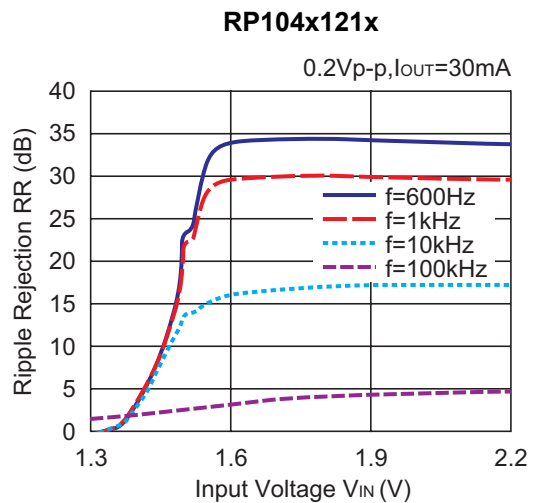
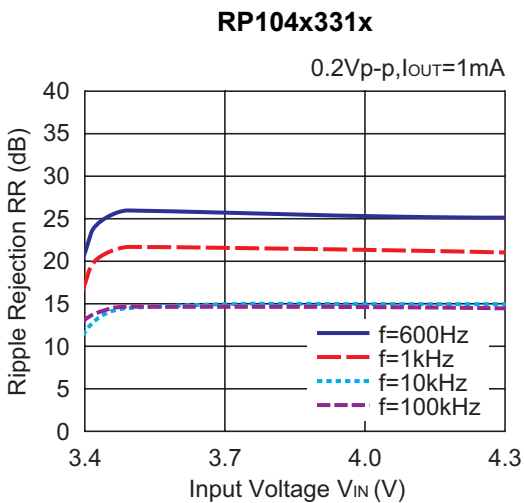
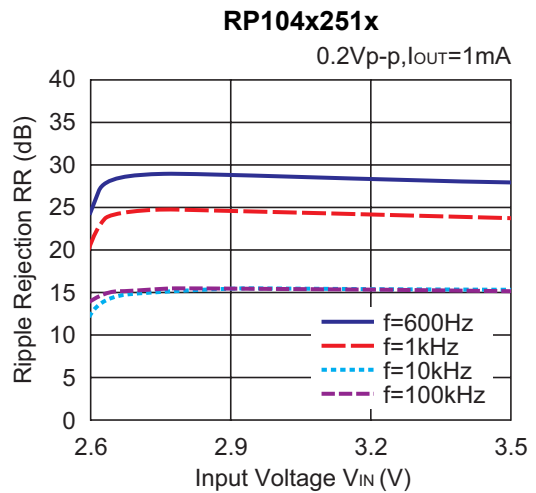
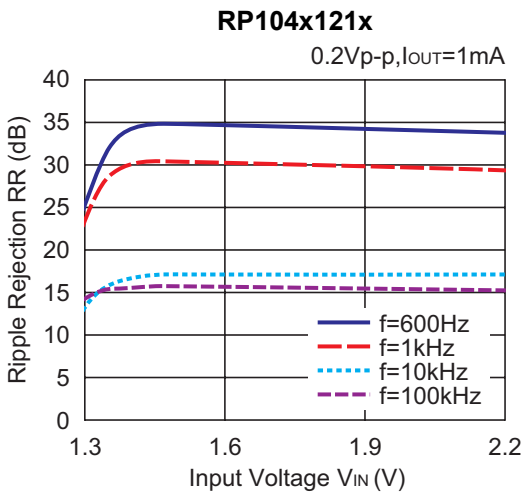

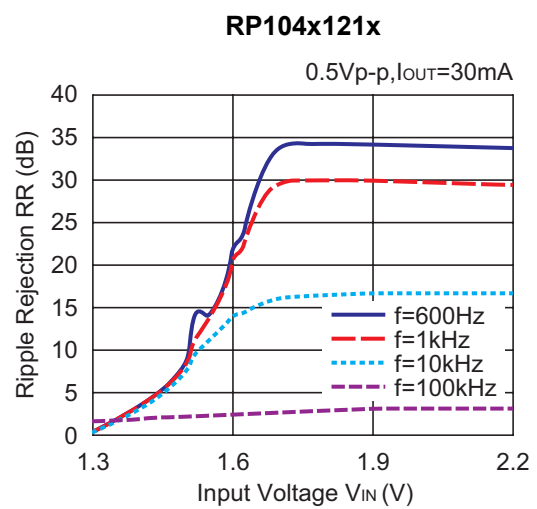
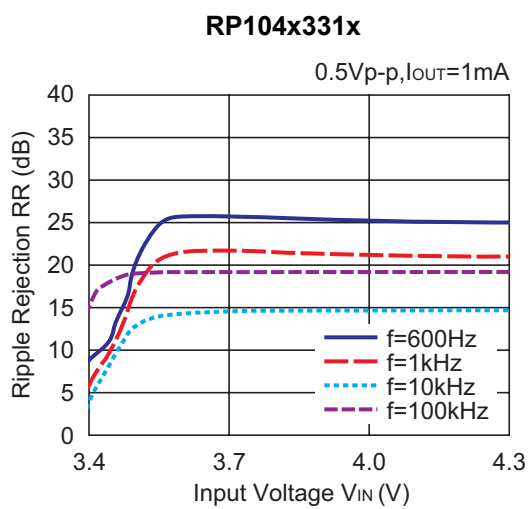
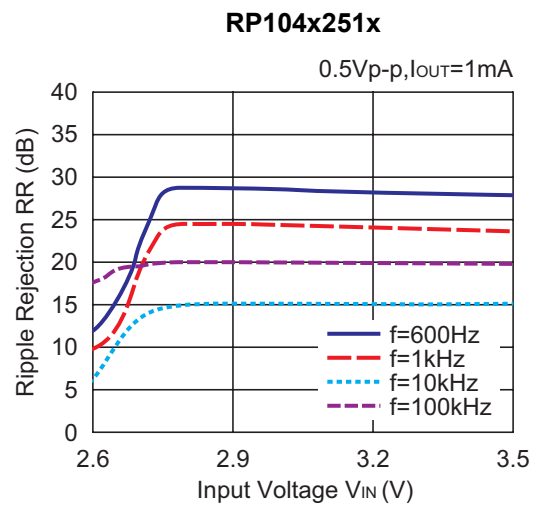
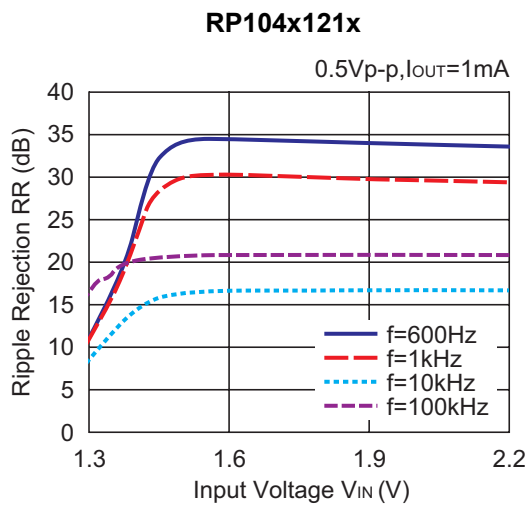
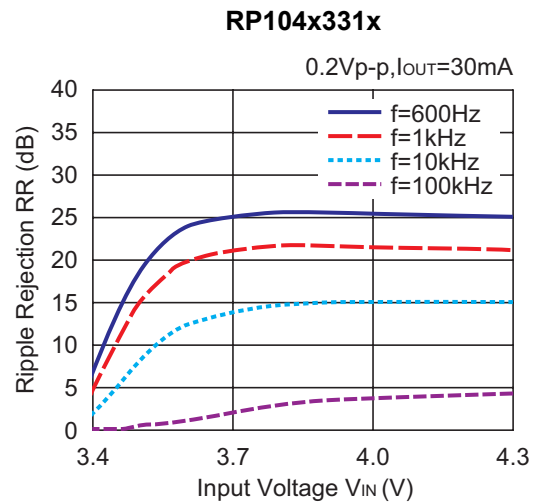
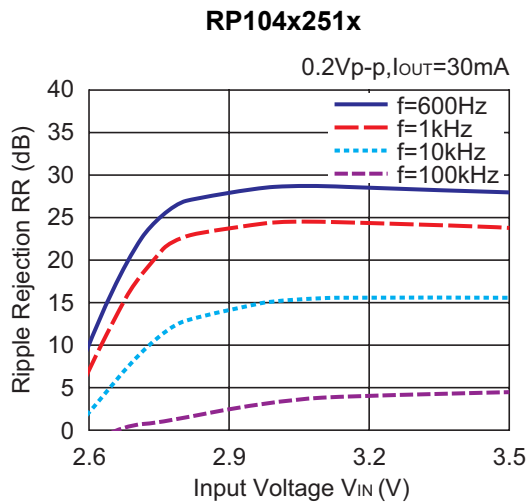

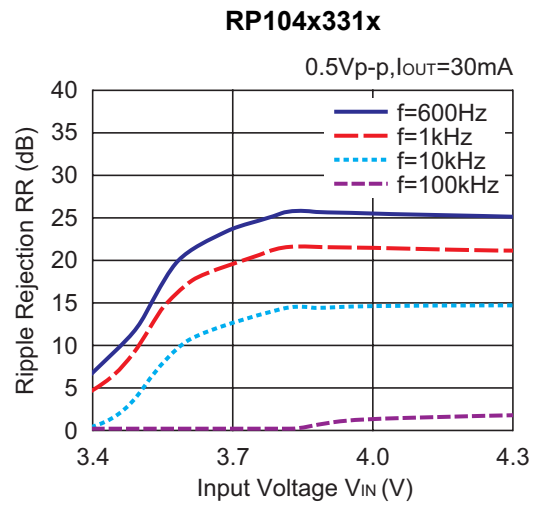
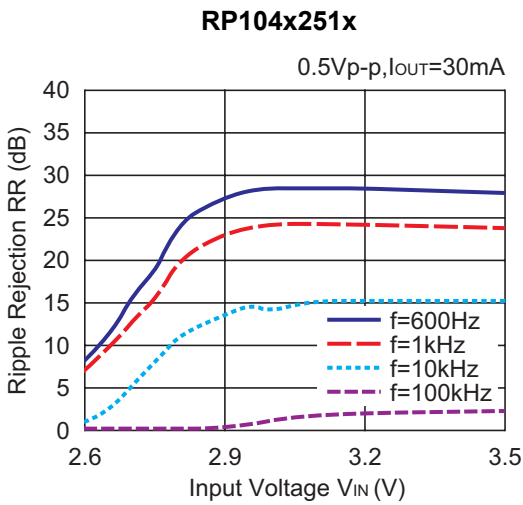

9) Ripple Rejection vs. Frequency (C1=none, C2=Ceramic 0.1μF, T_{opt}=25°C)

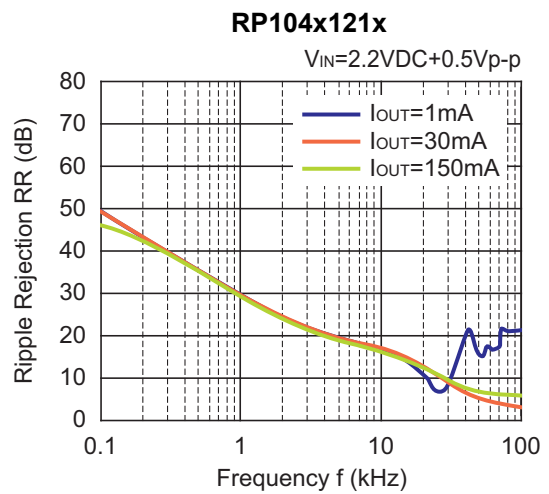
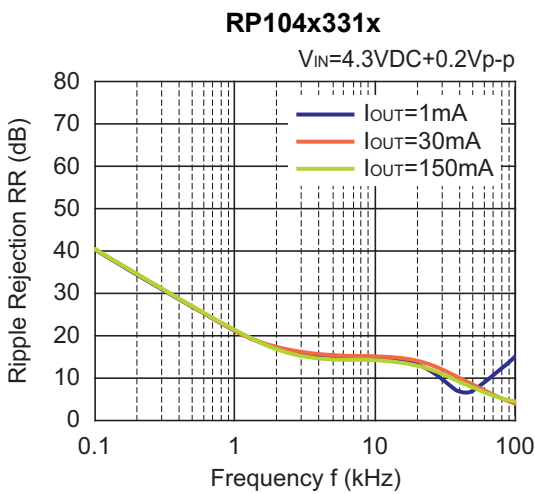
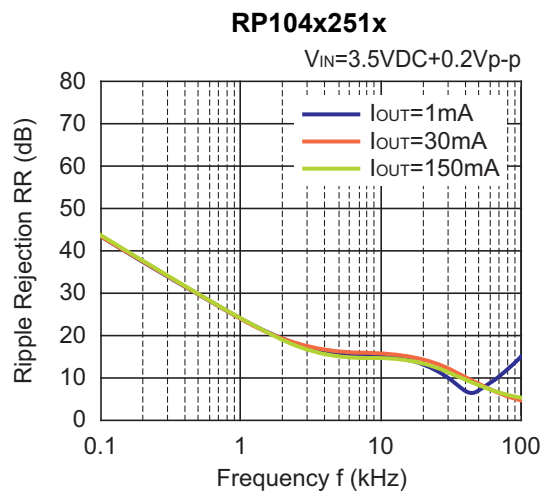
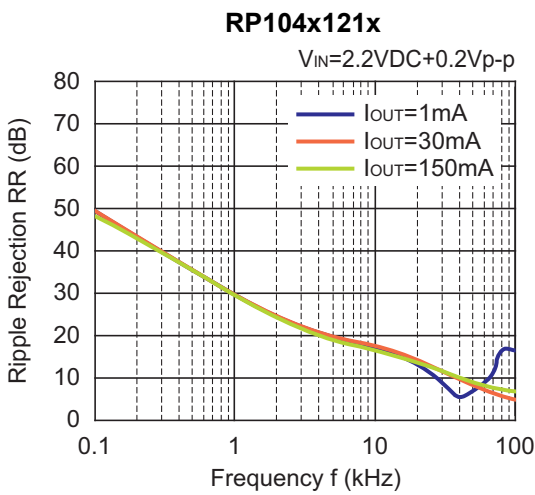

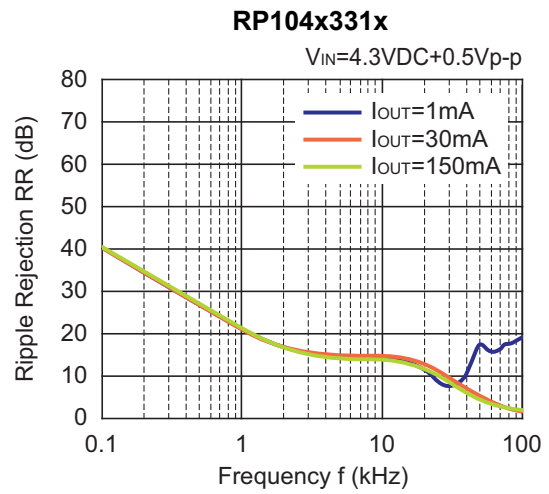
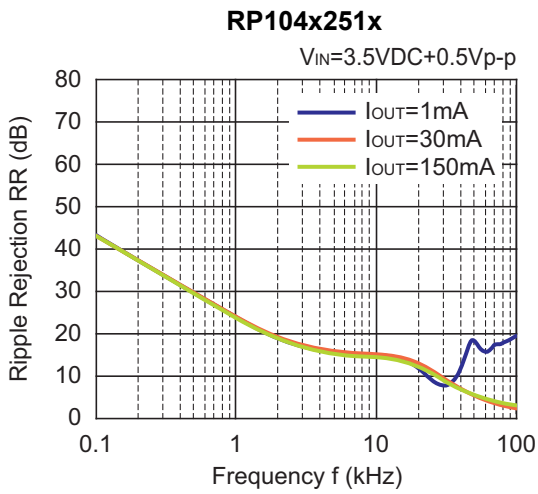

10) Input Transient Response ($C1=none$, $I_{OUT}=30mA$, $T_{opt}=25^{\circ}C$)

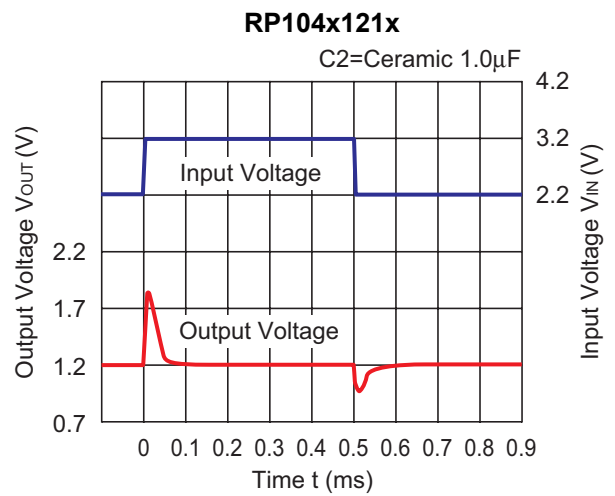
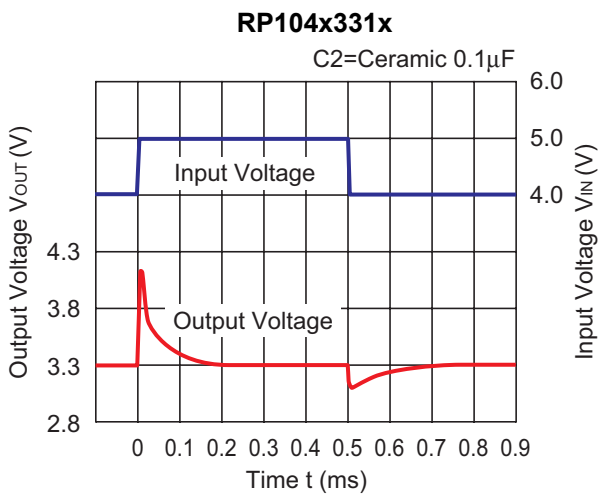
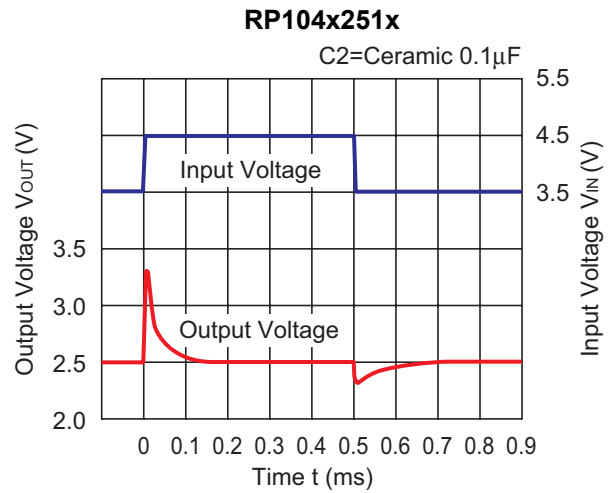
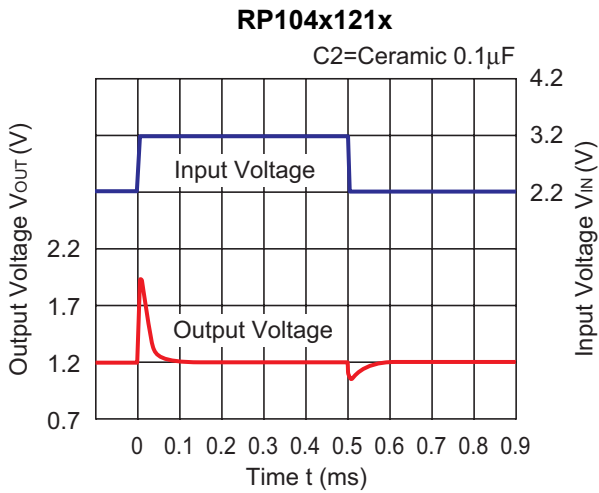

RP104x251x

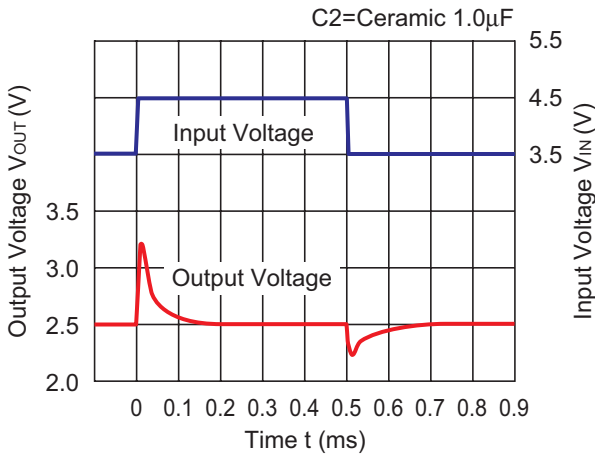

RP104x331x

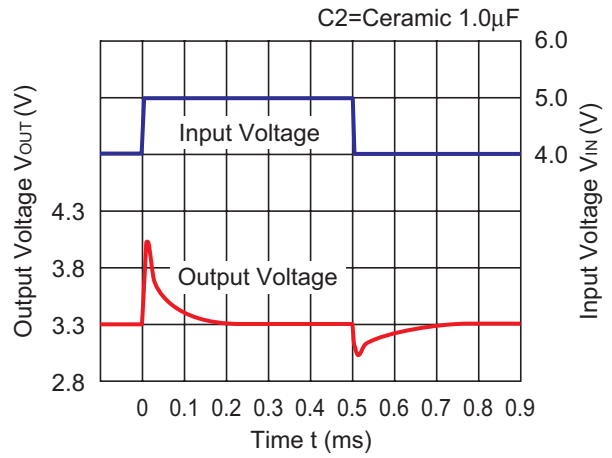

11) Load Transient Response (C1=Ceramic 0.1 μ F, T_{opt}=25°C)

RP104x121x

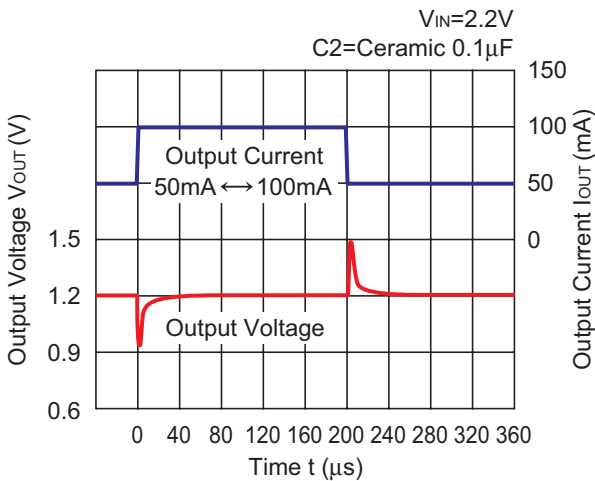

RP104x251x

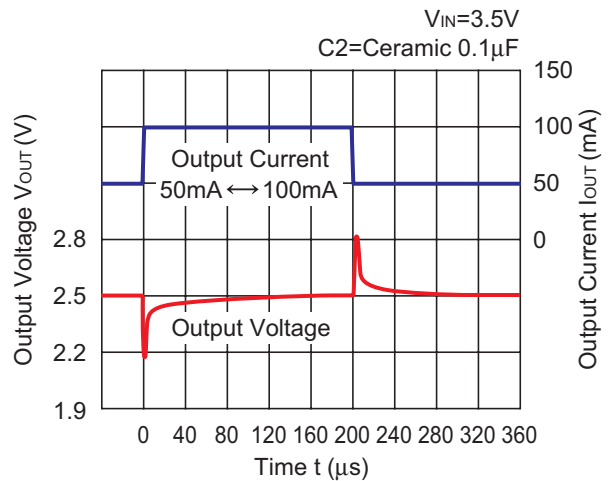

RP104x331x

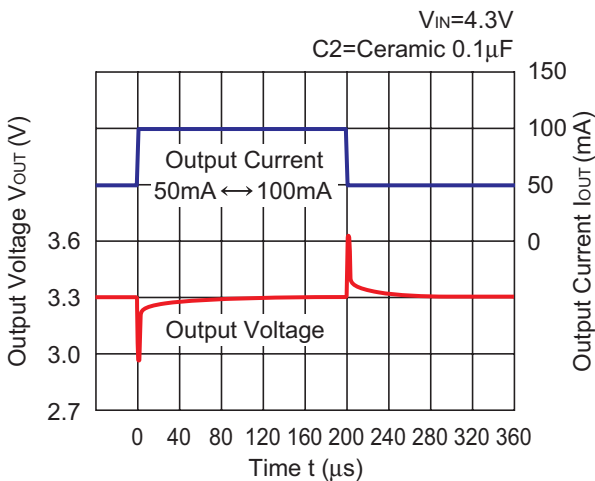

RP104x121x

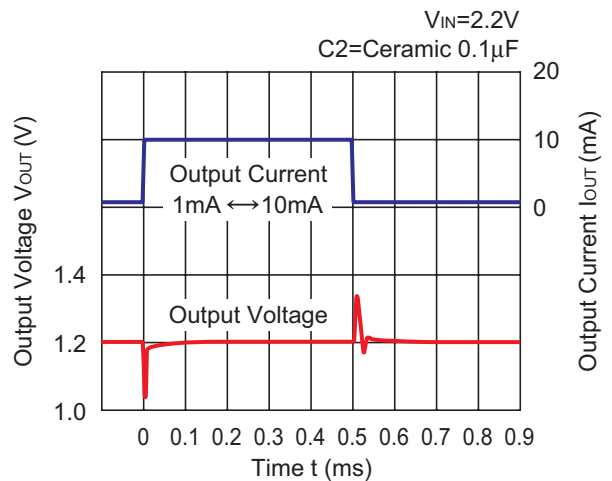

RP104x251x

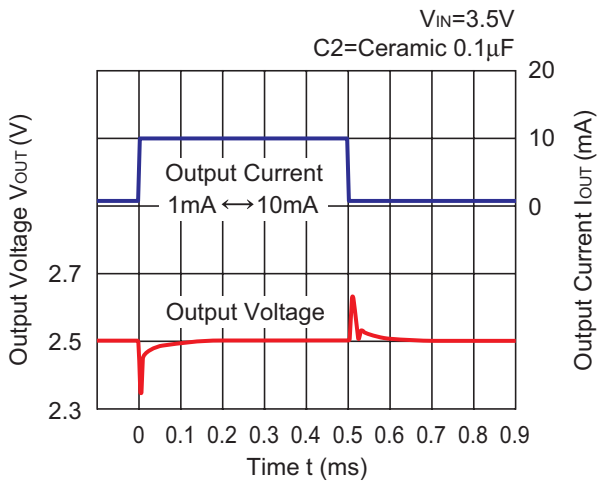

RP104x331x

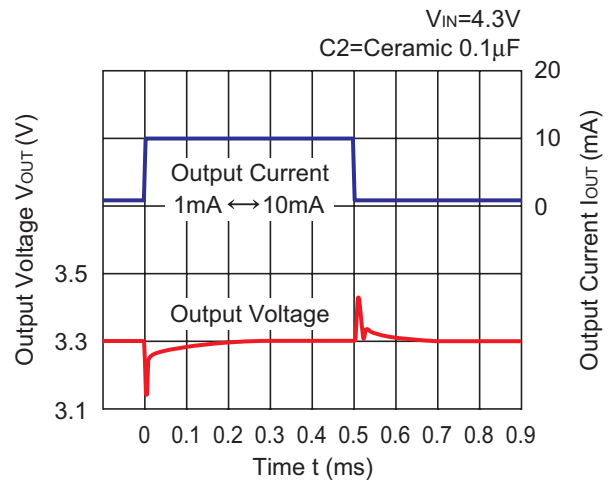

RP104x121x

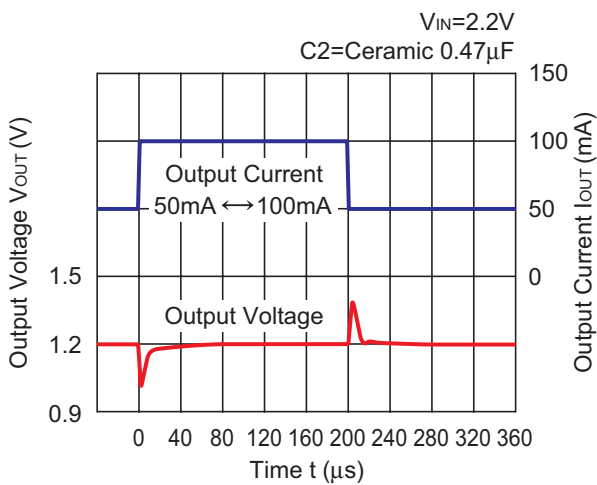

RP104x251x

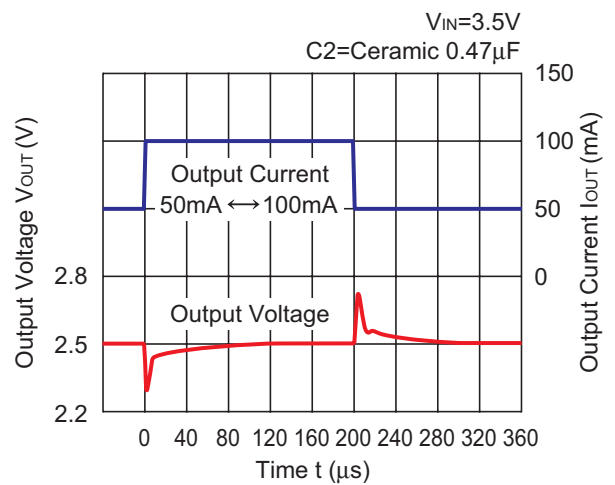

RP104x331x

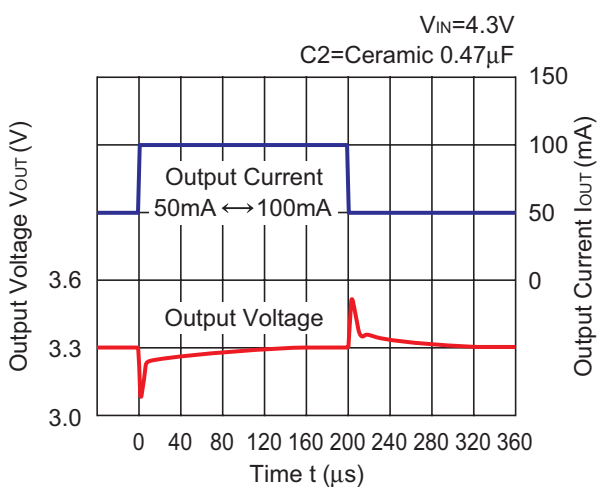

RP104x121x

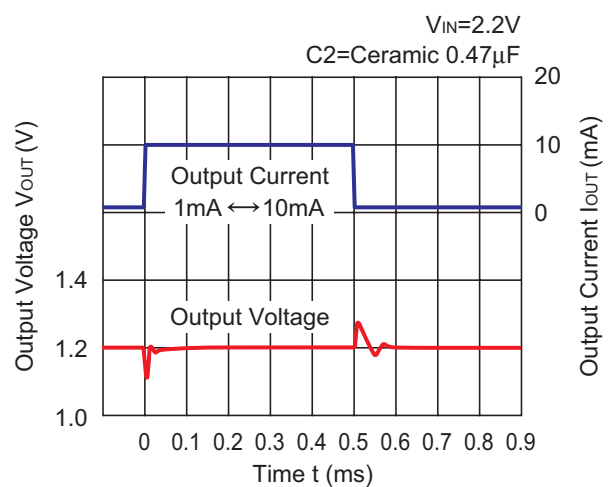

RP104x251x

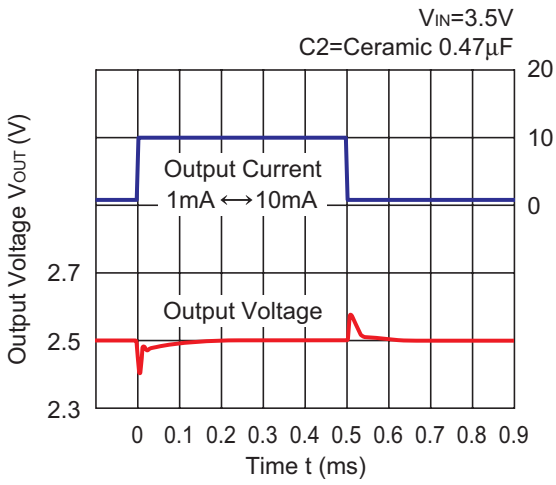

RP104x331x

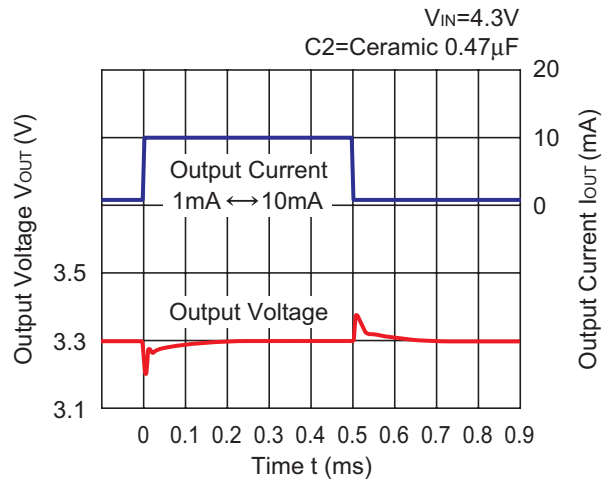

RP104x121x

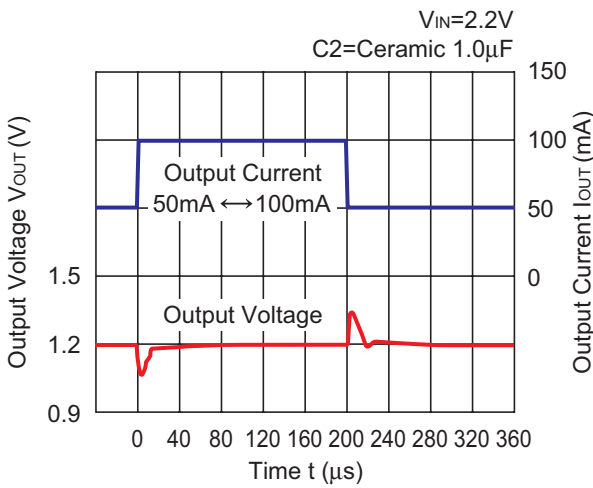

RP104x251x

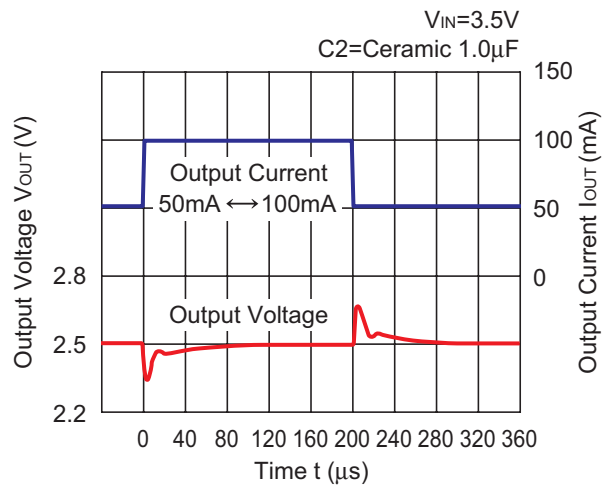

RP104x331x

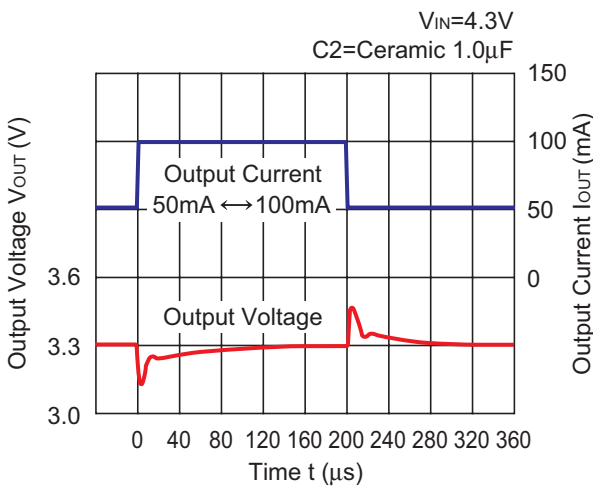

RP104x121x

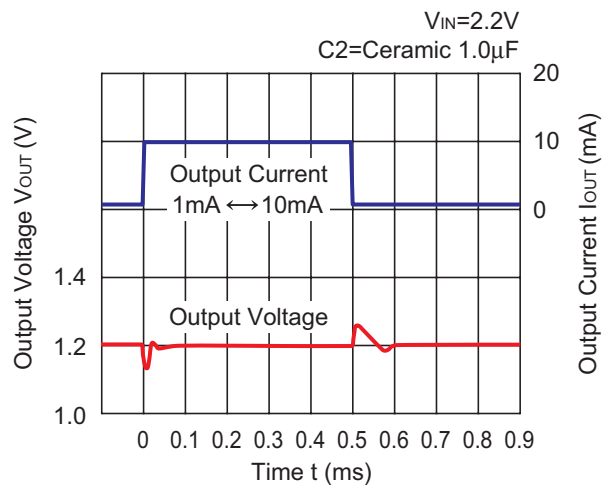

RP104x251x

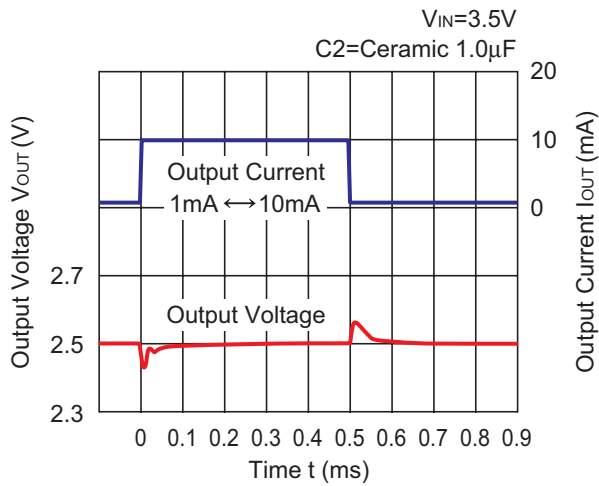

RP104x331x

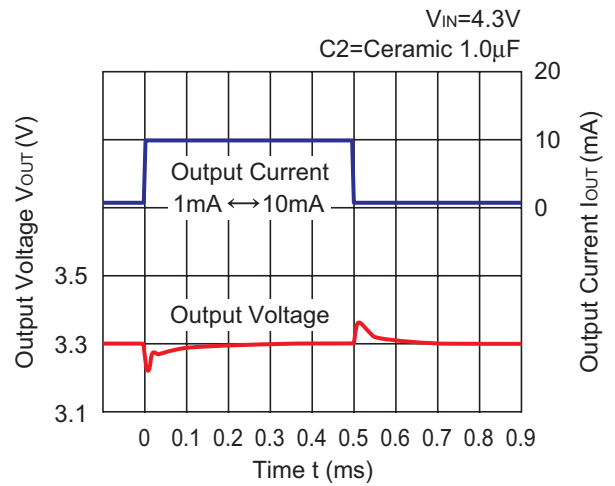

12) Turn On Speed with CE pin (C1=Ceramic 0.1 μF , C2=Ceramic 0.1 μF , $T_{opt}=25^{\circ}C$)

RP104x121B/D

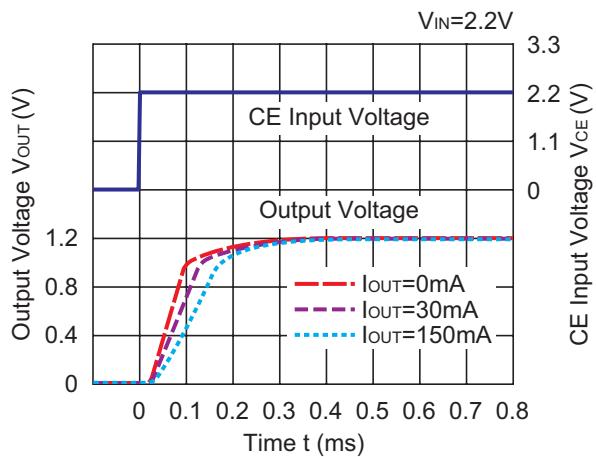

RP104x251B/D

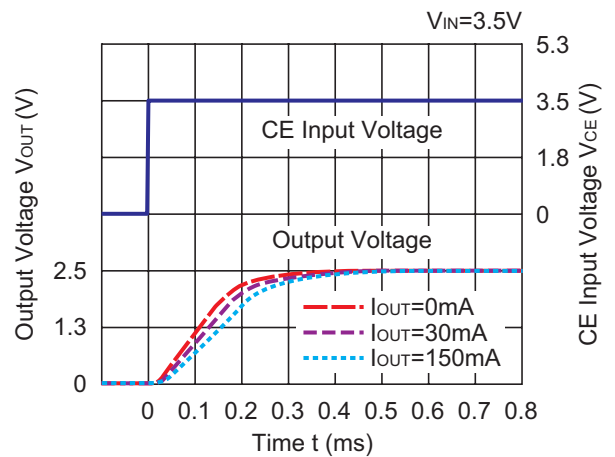

RP104x331B/D

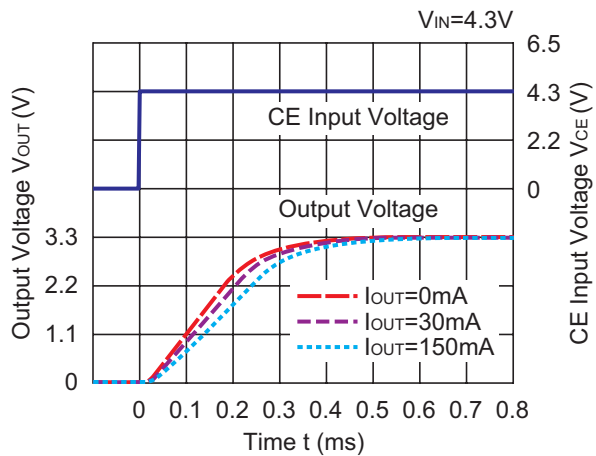

13) Turn Off Speed with CE pin (D Version) (C1=Ceramic 0.1μF, C2=Ceramic 0.1μF, T_{opt}=25°C)

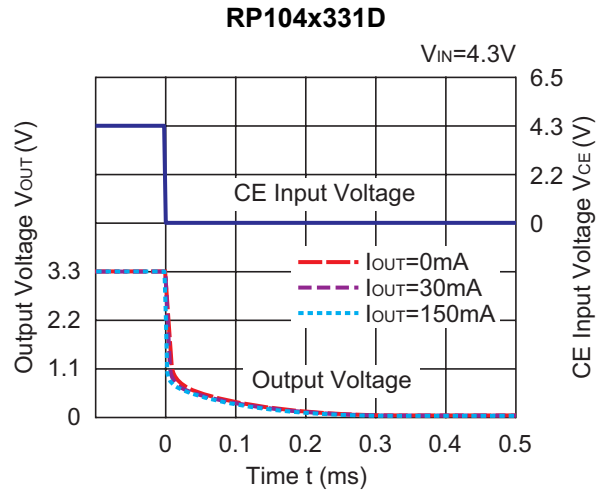
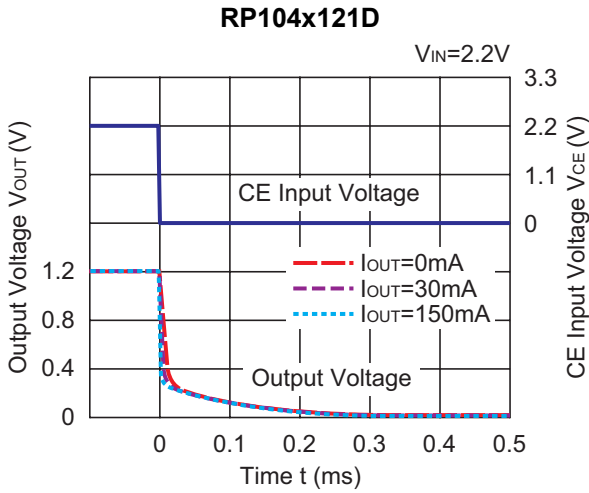

14) Turn On Speed of C Version (C1=Ceramic 0.1μF, C2=Ceramic 0.1μF, V_{IN}=5.0V, T_{opt}=25°C)

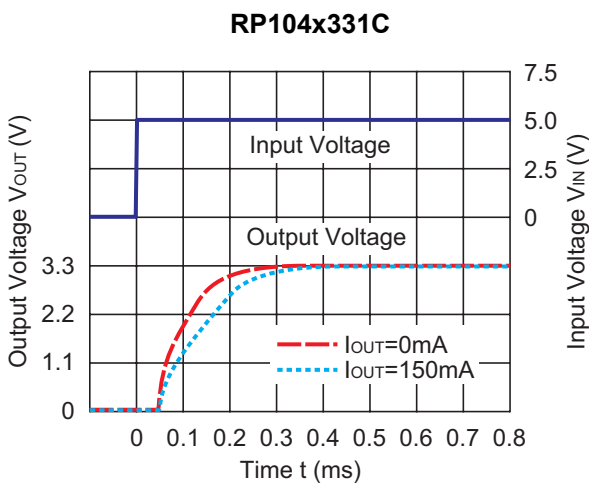
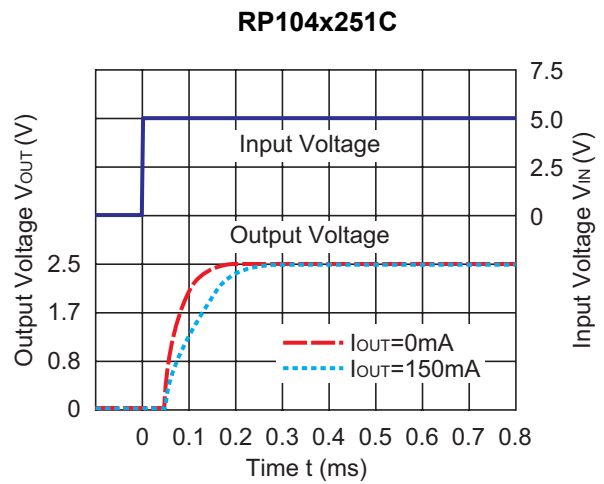
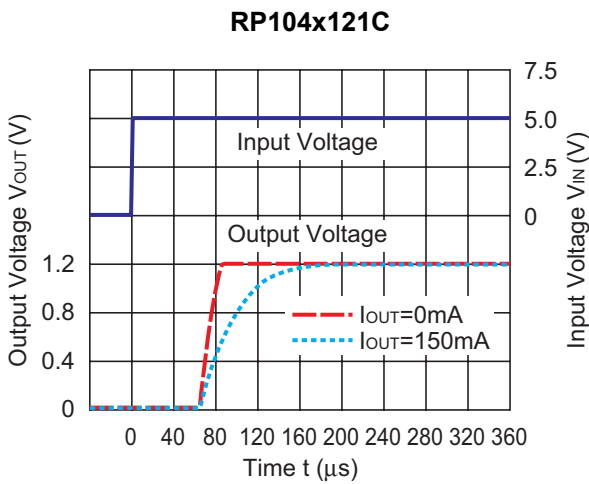

ESR vs. Output Current

When using these ICs, consider the following points:

The relations between I_{OUT} (Output Current) and ESR of an output capacitor are shown below.
 The conditions when the white noise level is under $40\mu\text{V}$ (Avg.) are marked as the hatched area in the graph.

Measurement conditions

Frequency Band : 10Hz to 2MHz

Temperature : -40°C to 85°C

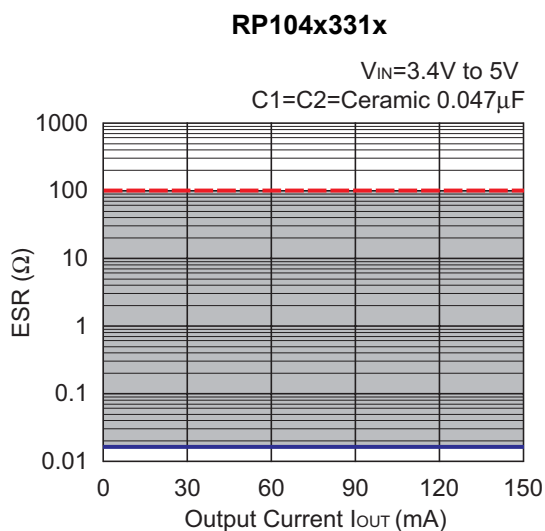
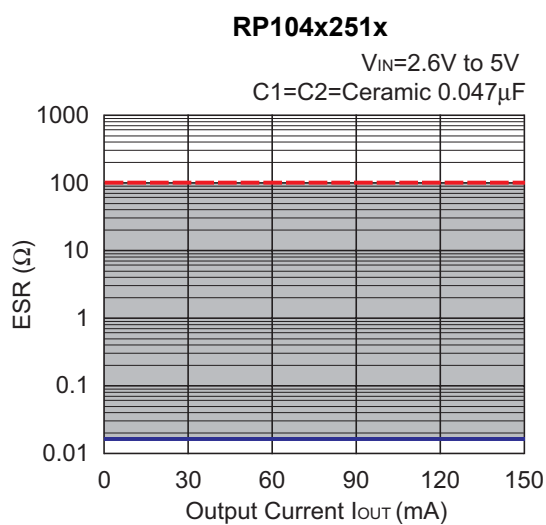
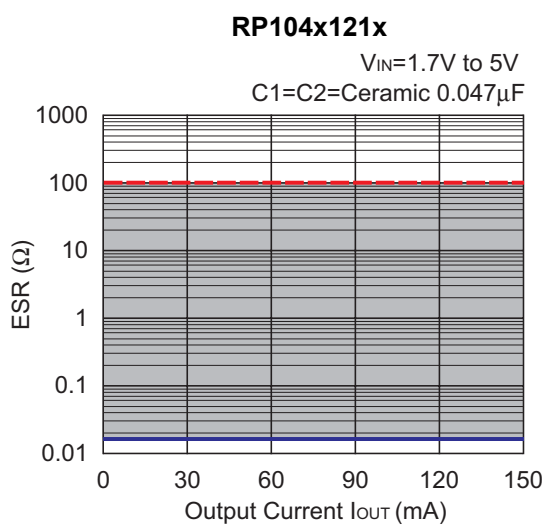

• PLP1010-4

Unit: mm

PACKAGE DIMENSIONS

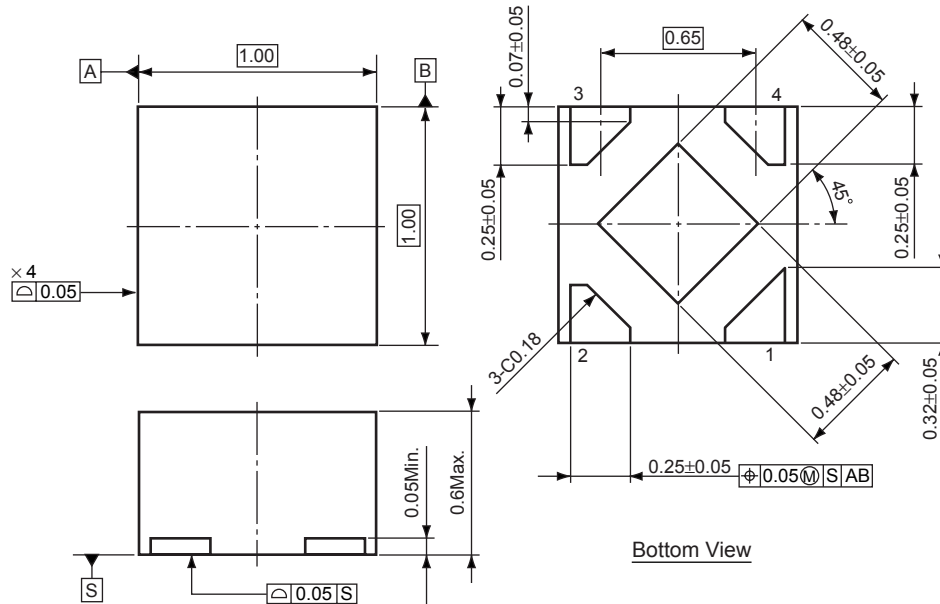

TAPING SPECIFICATION

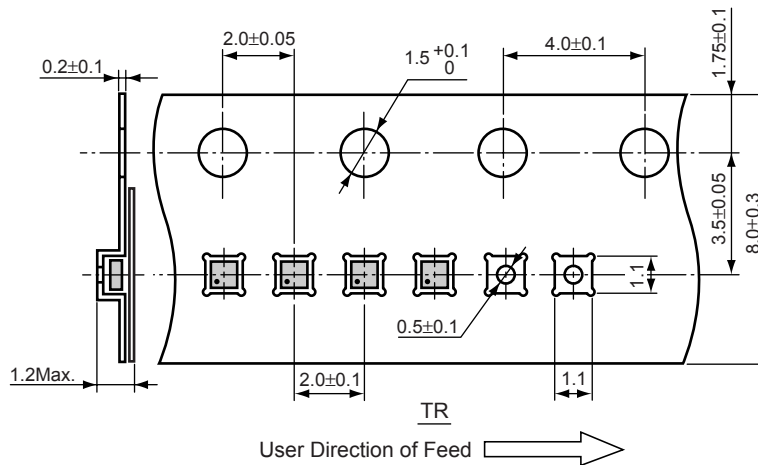

TAPING REEL DIMENSIONS REUSE REEL (EIAJ-RRM-08Bc)

(1reel=10000pcs)

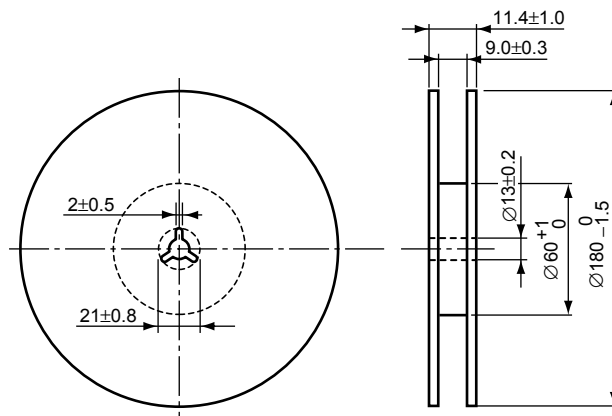

POWER DISSIPATION (PLP1010-4)

This specification is at mounted on board. Power Dissipation (P_D) depends on conditions of mounting on board. This specification is based on the measurement at the condition below:

Measurement Conditions

	Standard Land Pattern
Environment	Mounting on Board (Wind velocity=0m/s)
Board Material	Glass cloth epoxy plastic (Double sided)
Board Dimensions	40mm × 40mm × 1.6mm
Copper Ratio	Top side : Approx. 50% , Back side : Approx. 50%
Through-hole	φ0.54mm × 24pcs

Measurement Result ($T_{opt}=25^{\circ}\text{C}, T_{jmax}=125^{\circ}\text{C}$)

	Standard Land Pattern
Power Dissipation	400mW
Thermal Resistance	$\theta_{ja}=(125-25^{\circ}\text{C})/0.4\text{W}=250^{\circ}\text{C/W}$
Thermal Resistance	$\theta_{jc}=67^{\circ}\text{C/W}$

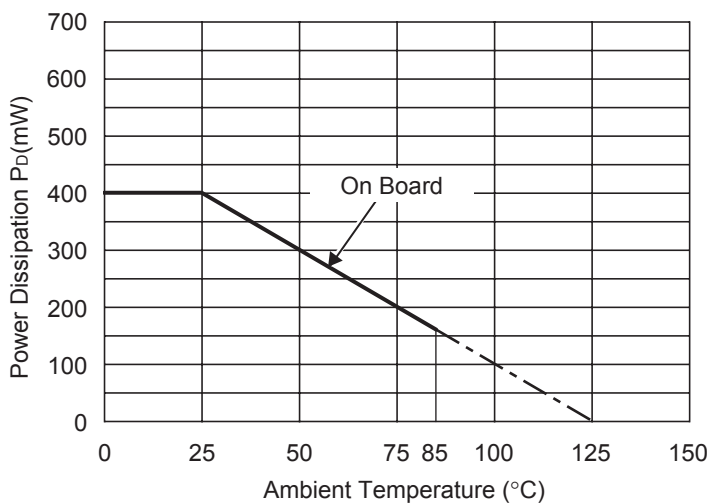

Power Dissipation

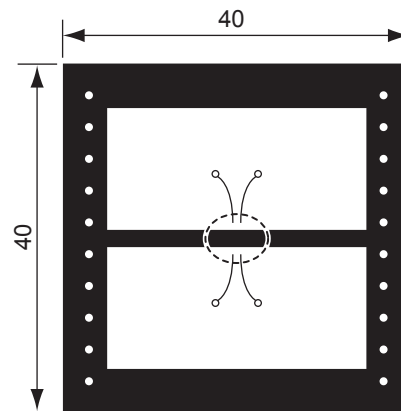

Measurement Board Pattern

○ IC Mount Area (Unit : mm)

RECOMMENDED LAND PATTERN

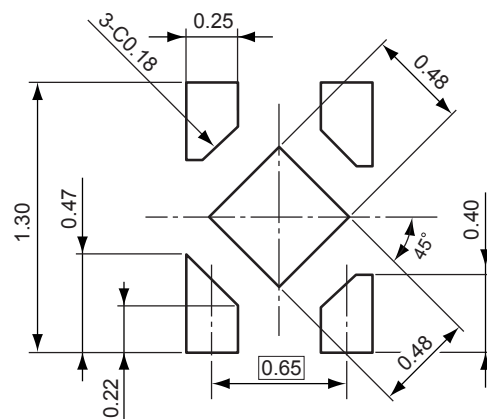

(Unit: mm)

- SOT-23-5 (SC-74A)

Unit: mm

PACKAGE DIMENSIONS

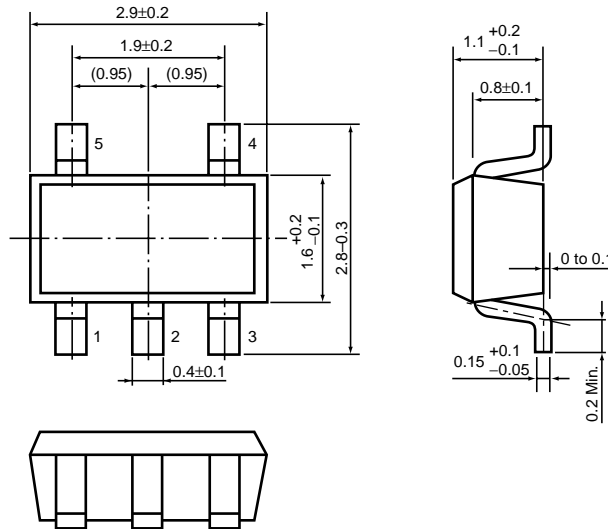

TAPING SPECIFICATION

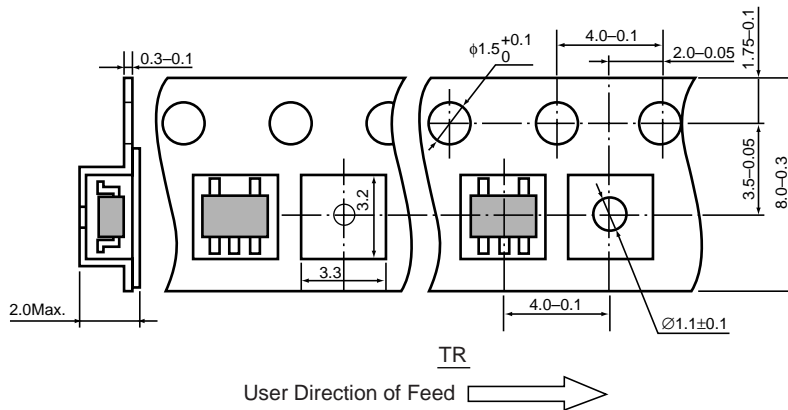

TAPING REEL DIMENSIONS REUSE REEL (EIAJ-RRM-08Bc)

(1reel=3000pcs)

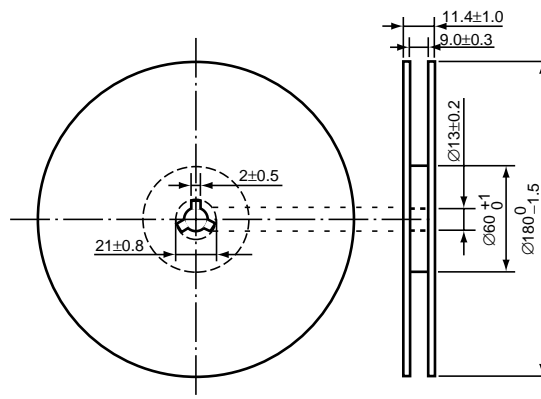

POWER DISSIPATION (SOT-23-5)

This specification is at mounted on board. Power Dissipation (P_D) depends on conditions of mounting on board. This specification is based on the measurement at the condition below:

(Power Dissipation (SOT-23-5) is substitution of SOT-23-6.)

Measurement Conditions

	Standard Land Pattern
Environment	Mounting on Board (Wind velocity=0m/s)
Board Material	Glass cloth epoxy plactic (Double sided)
Board Dimensions	40mm × 40mm × 1.6mm
Copper Ratio	Top side : Approx. 50% , Back side : Approx. 50%
Through-hole	φ0.5mm × 44pcs

Measurement Result

($T_{opt}=25^{\circ}C, T_{jmax}=125^{\circ}C$)

	Standard Land Pattern	Free Air
Power Dissipation	420mW	250mW
Thermal Resistance	$\theta_{ja}=(125-25^{\circ}C)/0.42W=263^{\circ}C/W$	400 $^{\circ}C/W$

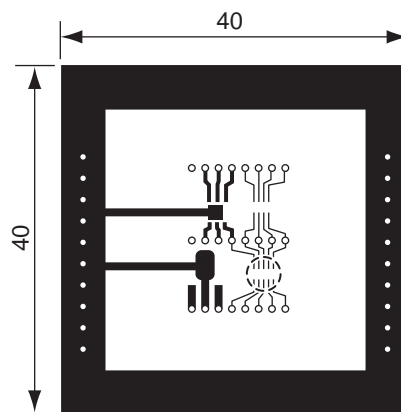
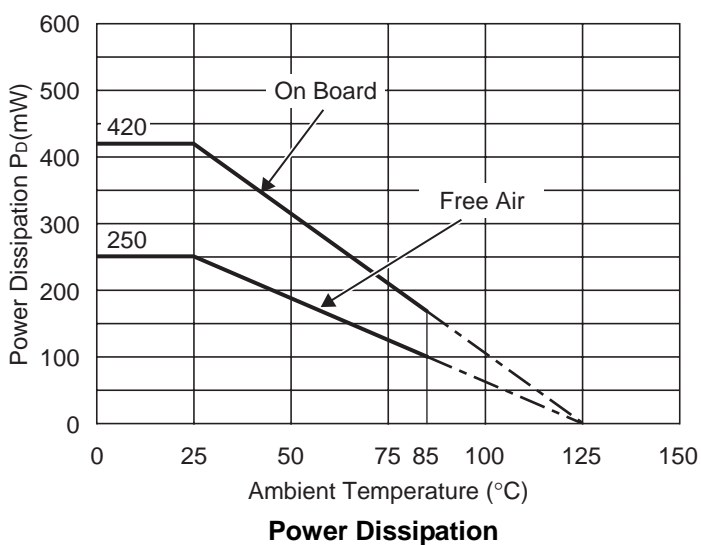

Measurement Board Pattern

○ IC Mount Area Unit : mm

RECOMMENDED LAND PATTERN

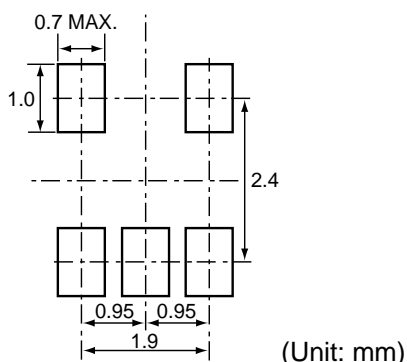

• SC-82AB

Unit: mm

PACKAGE DIMENSIONS

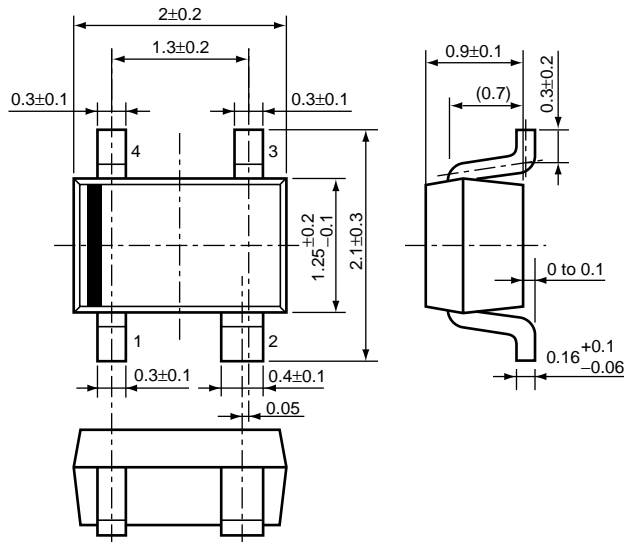

TAPING SPECIFICATION

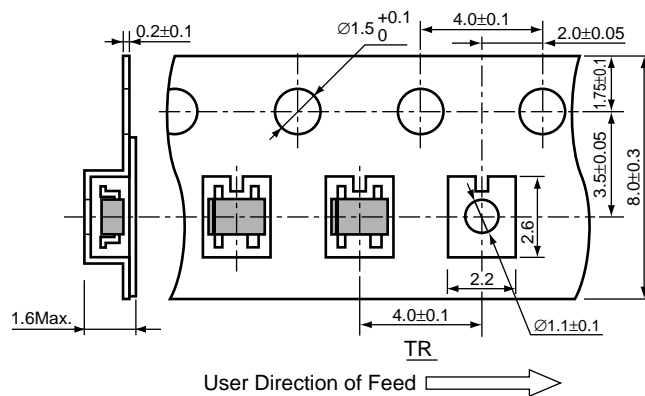

TAPING REEL DIMENSIONS

(1 reel=3000pcs)

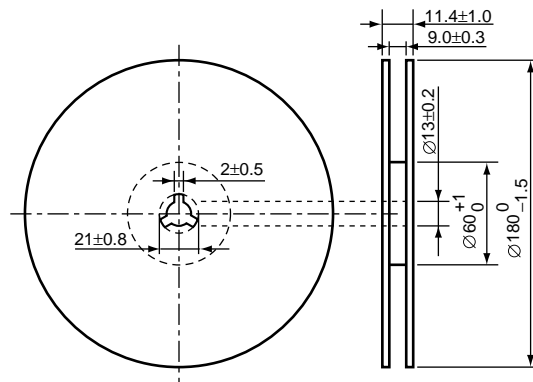

POWER DISSIPATION (SC-82AB)

This specification is at mounted on board. Power Dissipation (P_D) depends on conditions of mounting on board. This specification is based on the measurement at the condition below:

Measurement Conditions

	Standard Land Pattern
Environment	Mounting on Board (Wind velocity=0m/s)
Board Material	Glass cloth epoxy plactic (Double sided)
Board Dimensions	40mm × 40mm × 1.6mm
Copper Ratio	Top side : Approx. 50% , Back side : Approx. 50%
Through-hole	φ0.5mm × 44pcs

Measurement Result

($T_{opt}=25^{\circ}\text{C}$, $T_{jmax}=125^{\circ}\text{C}$)

	Standard Land Pattern	Free Air
Power Dissipation	380mW	150mW
Thermal Resistance	$\theta_{ja}=(125-25^{\circ}\text{C})/0.38\text{W}=263^{\circ}\text{C/W}$	667 $^{\circ}\text{C/W}$

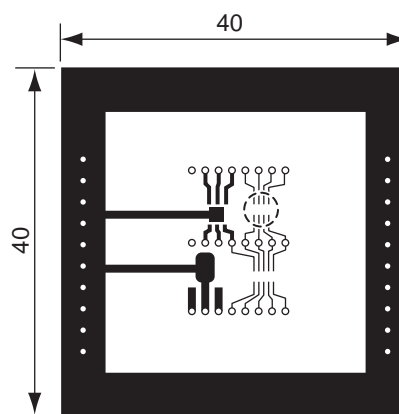
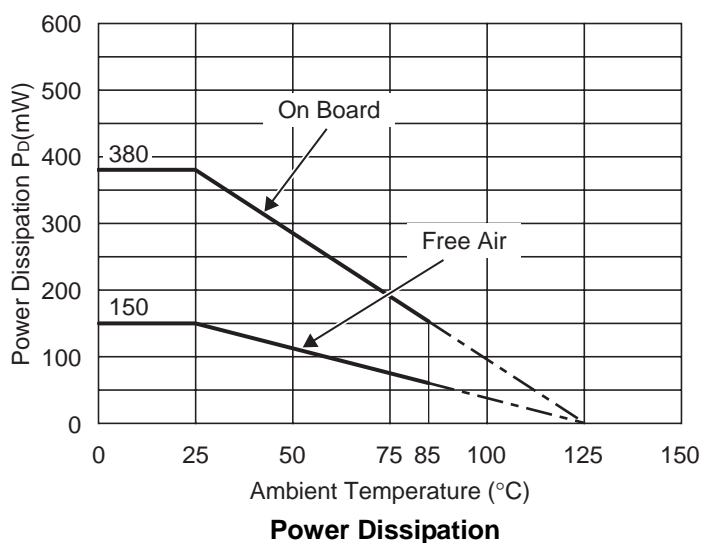

Measurement Board Pattern

○ IC Mount Area (Unit : mm)

RECOMMENDED LAND PATTERN

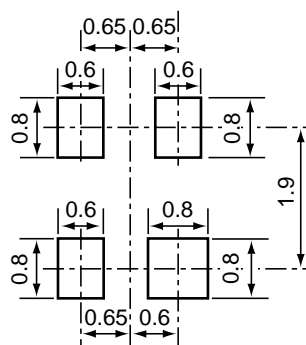

(Unit: mm)

RP104K SERIES MARK SPECIFICATION

● **PLP1010-4**

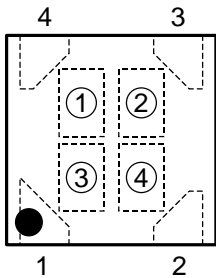

①, ② : Product Code (Refer to Part Number vs. Product Code)

③, ④ : Lot Number

● **Part Number vs. Product Code**

Part Number	Product Code		Part Number	Product Code		Part Number	Product Code	
	①	②		①	②		①	②
RP104K121B	A	A	RP104K121C	B	A	RP104K121D	C	A
RP104K131B	A	B	RP104K131C	B	B	RP104K131D	C	B
RP104K151B	A	C	RP104K151C	B	C	RP104K151D	C	C
RP104K181B	A	D	RP104K181C	B	D	RP104K181D	C	D
RP104K181B5	A	E	RP104K181C5	B	E	RP104K181D5	C	E
RP104K191B	A	F	RP104K191C	B	F	RP104K191D	C	F
RP104K201B	A	G	RP104K201C	B	G	RP104K201D	C	G
RP104K251B	A	H	RP104K251C	B	H	RP104K251D	C	H
RP104K261B	A	J	RP104K261C	B	J	RP104K261D	C	J
RP104K271B	A	K	RP104K271C	B	K	RP104K271D	C	K
RP104K281B	A	L	RP104K281C	B	L	RP104K281D	C	L
RP104K281B5	A	M	RP104K281C5	B	M	RP104K281D5	C	M
RP104K291B	A	N	RP104K291C	B	N	RP104K291D	C	N
RP104K301B	A	P	RP104K301C	B	P	RP104K301D	C	P
RP104K321B	A	Q	RP104K321C	B	Q	RP104K321D	C	Q
RP104K331B	A	R	RP104K331C	B	R	RP104K331D	C	R

RP104N SERIES MARK SPECIFICATION

• SOT-23-5

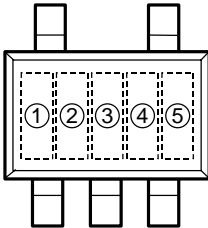

①, ②, ③ : Product Code (Refer to Part Number vs. Product Code)

④, ⑤ : Lot Number

• Part Number vs. Product Code

Part Number	Product Code			Part Number	Product Code			Part Number	Product Code		
	①	②	③		①	②	③		①	②	③
RP104N121B	9	0	A	RP104N121C	9	1	A	RP104N121D	9	2	A
RP104N131B	9	0	B	RP104N131C	9	1	B	RP104N131D	9	2	B
RP104N151B	9	0	C	RP104N151C	9	1	C	RP104N151D	9	2	C
RP104N181B	9	0	D	RP104N181C	9	1	D	RP104N181D	9	2	D
RP104N181B5	9	0	E	RP104N181C5	9	1	E	RP104N181D5	9	2	E
RP104N191B	9	0	F	RP104N191C	9	1	F	RP104N191D	9	2	F
RP104N201B	9	0	G	RP104N201C	9	1	G	RP104N201D	9	2	G
RP104N251B	9	0	H	RP104N251C	9	1	H	RP104N251D	9	2	H
RP104N261B	9	0	J	RP104N261C	9	1	J	RP104N261D	9	2	J
RP104N271B	9	0	K	RP104N271C	9	1	K	RP104N271D	9	2	K
RP104N281B	9	0	L	RP104N281C	9	1	L	RP104N281D	9	2	L
RP104N281B5	9	0	M	RP104N281C5	9	1	M	RP104N281D5	9	2	M
RP104N291B	9	0	N	RP104N291C	9	1	N	RP104N291D	9	2	N
RP104N301B	9	0	P	RP104N301C	9	1	P	RP104N301D	9	2	P
RP104N321B	9	0	Q	RP104N321C	9	1	Q	RP104N321D	9	2	Q
RP104N331B	9	0	R	RP104N331C	9	1	R	RP104N331D	9	2	R

RP104Q SERIES MARK SPECIFICATION

• SC-82AB

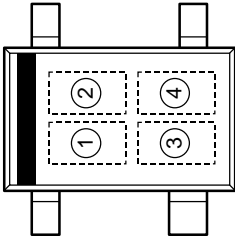

①, ② : Product Code (Refer to Part Number vs. Product Code)

③, ④ : Lot Number

• Part Number vs. Product Code

Part Number	Product Code		Part Number	Product Code		Part Number	Product Code	
	①	②		①	②		①	②
RP104Q121B	L	0	RP104Q121C	N	0	RP104Q121D	R	0
RP104Q131B	L	1	RP104Q131C	N	1	RP104Q131D	R	1
RP104Q151B	L	2	RP104Q151C	N	2	RP104Q151D	R	2
RP104Q181B	L	3	RP104Q181C	N	3	RP104Q181D	R	3
RP104Q181B5	L	4	RP104Q181C5	N	4	RP104Q181D5	R	4
RP104Q191B	L	5	RP104Q191C	N	5	RP104Q191D	R	5
RP104Q201B	L	6	RP104Q201C	N	6	RP104Q201D	R	6
RP104Q251B	L	7	RP104Q251C	N	7	RP104Q251D	R	7
RP104Q261B	L	8	RP104Q261C	N	8	RP104Q261D	R	8
RP104Q271B	L	9	RP104Q271C	N	9	RP104Q271D	R	9
RP104Q281B	M	0	RP104Q281C	P	0	RP104Q281D	S	0
RP104Q281B5	M	1	RP104Q281C5	P	1	RP104Q281D5	S	1
RP104Q291B	M	2	RP104Q291C	P	2	RP104Q291D	S	2
RP104Q301B	M	3	RP104Q301C	P	3	RP104Q301D	S	3
RP104Q321B	M	4	RP104Q321C	P	4	RP104Q321D	S	4
RP104Q331B	M	5	RP104Q331C	P	5	RP104Q331D	S	5