

SMD-50

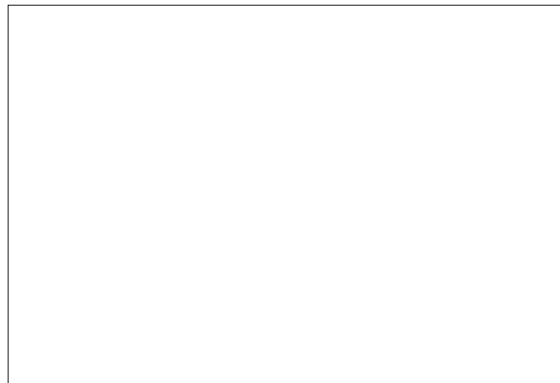

Rectifier Diode



Type	V_{RRM}	$I_{FAVM} (T_c, ^\circ C)$	I_{FRMS}	I_{FSM}	i^2t	V_{FM}	I_{FM}	V_{FO}	r_F	T_{VJM}	R_{thJC}
	V	A	A	A	kA^2s	V	A	V	$m\Omega$	$^\circ C$	K/W
SMD-50	100-1200	50 (140)	78	800	3.2	1.40	220	0.77	4.3	150	1.0

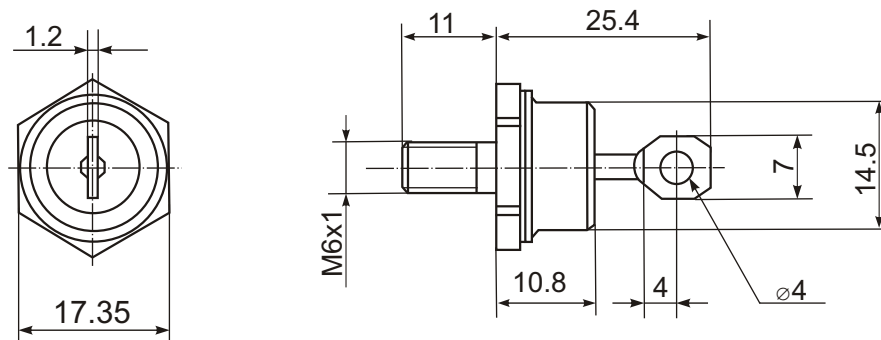

SMD-50



SMD-50R



Features:

- Hermetic metal case with ceramic insulator
- Capacity of supporting high surge current
- International standard case

Typical Applications:

- AC/DC converters
- DC power supplies
- Machine tool controls