

Features and Benefits

- Soft Switching for low noise
- Low supply voltage: 1.8V to 6.5V
- Full Bridge driver
- High sensitivity integrated Hall sensor
- Low power consumption
- Reverse voltage protection
- Locked rotor protection and auto-restart
- Thermal protection and auto-restart
- Tachometer output signal (US168) or Alarm output signal (US169)

Applications Examples

- 3V / 5V Low Noise BLDC Cooling Fans
- Low Voltage / Low Power BLDC Motors
- Notebook DC Fans / Blowers
- Automotive Low Noise Climate Control Fans
- Micro-Motors

Ordering Information

Part No.	Temperature Code	Package Code
US168	E (-40°C to 85°C)	SE (TSOT-5L)
US169	E (-40°C to 85°C)	SE (TSOT-5L)

1 Functional Diagram

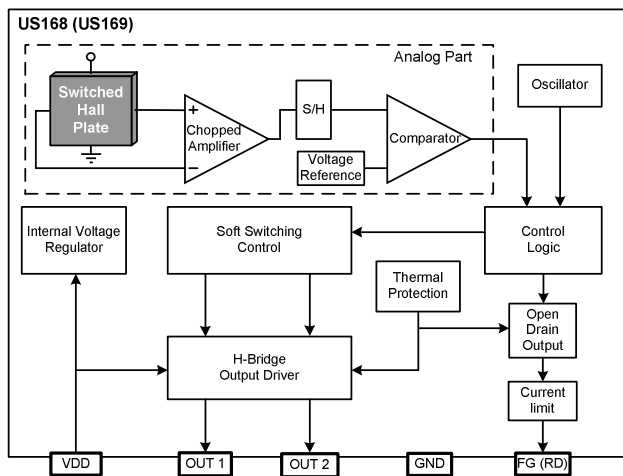

2 General Description

The US168/169 is a one-chip solution for driving single-coil brushless DC fans and motors.

The use of Melexis Soft Switching concept lowers the acoustic and electrical motor noise and provides smoother operation.

The device includes reverse voltage protection, locked rotor protection and thermal protection. Therefore, the IC robustness perfectly suits for consumer and automotive-on-board applications.

Tachometer (FG) or Alarm (RD) open-drain output is available. It makes easier the connectivity with external interface such as hardware monitoring or Super I/O IC.

Delivered in a thin and reliable TSOT package, it allows smaller and competitive single-coil fan or motor design, avoiding the need of external components.

Table of Contents

1 Functional Diagram	1
2 General Description.....	1
3 Glossary of Terms	3
4 Absolute Maximum Ratings.....	3
5 Pin Definitions and Descriptions.....	3
6 General Electrical Specifications	4
7 Magnetic Specifications	4
8 Outputs Behaviour vs. Magnetic Pole.....	4
9 Detailed General Description.....	5
10 Unique Features.....	6
11 Typical Performance Graphs	7
11.1 R_{ON} vs. T_A	7
11.2 R_{ON} vs. V_{DD}	7
11.3 Magnetic Parameters vs. T_A	7
11.4 Magnetic Parameters vs. V_{DD}	7
11.5 Slope duration vs. T_A	7
11.6 Slope duration vs. V_{DD}	7
11.7 I_{DD} vs. V_{DD}	8
11.8 V_{OL} vs. T_A	8
11.9 Power dissipation graph	8
11.10 Recommended maximum continuous output current vs. V_{DD}	8
12 Test Circuits.....	9
12.1 Supply Current.....	9
12.2 Full Bridge ON Resistance	9
12.3 Output Switching Slope Duration.....	9
12.4 Soft Switching Threshold Voltage.....	9
12.5 FG/RD Output Low Voltage.....	9
12.6 FG/RD Output Current Limit.....	9
12.7 FG/RD Output Leakage Current.....	9
12.8 Thermal Protection	9
13 Application Information.....	10
14 Application Comments.....	10
15 Standard information regarding manufacturability of Melexis products with different soldering processes.....	11
16 ESD Precautions	11
17 Package Information.....	12
18 Disclaimer.....	13

3 Glossary of Terms

Gauss, milliTesla (mT),	Units of magnetic flux density : 10 Gauss = 1mT
Single-coil motor	DC motor with only one coil driven by a Full-Bridge.
Full-Bridge (H-Bridge)	Two push-pull output drivers that can source or sink current.
Peak output current	The current flowing in the coil at start-up, only limited by the coil resistance R_{COIL} and the output driver resistance R_{DSON} .
Continuous output current	Average absolute value of the output current when the fan is spinning
Locked rotor	The state when the fan is not spinning due to mechanical blockage.
FG	Frequency Generator
RD	Rotation Detection

4 Absolute Maximum Ratings

Parameter	Symbol	Value	Units	
Supply Voltage	V_{DD}	-7 to 7	V	
Voltage on FG (RD) pin	$V_{FG} (V_{RD})$	-6 to 7	V	
Peak Output Current	I_{OUTp}	500	mA	
Continuous Output Current	Multi-layer (1S2P) PCB	I_{OUTc}	350	mA
	Single-layer (1S0P) PCB	I_{OUTc}	300	mA
Operating Temperature Range	T_A	-40 to 85	°C	
Junction Temperature	T_J	125	°C	
Storage Temperature Range	T_S	-50 to 150	°C	
Magnetic Flux Density	B	Unlimited	mT	
ESD Sensitivity (Global) ⁽¹⁾	-	1500	V	
ESD Sensitivity on all pins except FG/RD ⁽¹⁾	-	5000	V	

Table 1: Absolute maximum ratings

Note 1: Human Body Model according JESD22-A114 standard – 100pF capacitor discharged through 1.5kΩ resistor into each pin.

Exceeding the absolute maximum ratings may cause permanent damage. Exposure to absolute-maximum-rated conditions for extended periods may affect device reliability.

5 Pin Definitions and Descriptions

Pin Number	Pin Name	Function
1	OUT1	Coil Driver 1
2	GND	Ground pin
3	VDD	Power Supply pin
4	FG (RD)	Tachometer (Alarm) open drain output
5	OUT2	Coil Driver 2

Table 2: Pin description US168 (US169)

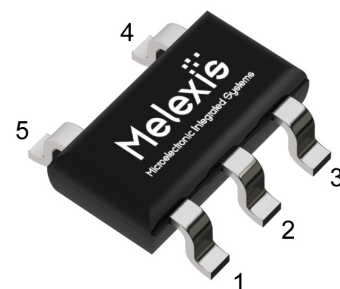

6 General Electrical Specifications

Operating Parameters at $T_A = 25^\circ\text{C}$, $V_{DD} = 3\text{V} / 5\text{V}$ (unless otherwise specified)

Parameter	Symbol	Test Conditions	Min	Typ	Max	Units
Supply Voltage	V_{DD}	Operating	1.8	-	6.5	V
Supply Current	I_{DD}	No load on OUT1/OUT2		1.3	2.5	mA
Output ON Resistance (Full Bridge)	R_{ON}	$V_{DD} = 5\text{V}$	$T_A = 25^\circ\text{C}$	2.2	3.8	Ω
			$T_A = 85^\circ\text{C}$	2.7	4.7	Ω
		$V_{DD} = 3\text{V}$	$T_A = 25^\circ\text{C}$	2.7	4.7	Ω
			$T_A = 85^\circ\text{C}$	3.3	5.9	Ω
FG / RD Output Low Voltage	V_{OL}	$I_{OL} = 4\text{mA}$		0.35	0.5	V
FG / RD Output Leakage Current	I_{LEAK}	$V_{DD} = 6.5\text{V}$			10	μA
FG / RD Output Current Limit	I_{FGLIM}	$V_{DD} = 5\text{V}$		16		mA
Soft Switching Threshold Voltage	V_{DDsw}			1.8	2.5	V
Output Switching Slope Duration	T_{SW}	$V_{DD} = 5\text{V}$		150		μs
Output Switching Slope Duration	T_{SW}	$V_{DD} = 3\text{V}$		230		μs
Locked Rotor ON Time	T_{ON}			0.4		s
Locked Rotor OFF Time	T_{OFF}			2.4		s
Thermal Protection Shutdown	T_{SD}	Note 2		160		$^\circ\text{C}$
Thermal Protection Release	T_{REL}	Note 2		130		$^\circ\text{C}$
Thermal Protection Hysteresis	T_{HYST}	Note 2		30		$^\circ\text{C}$
Sensing Propagation Delay ⁽³⁾	T_{SENSE}			37		μs
Package Thermal Resistance	R_{TH}	Multi-layer JEDEC test board		195		$^\circ\text{C}/\text{Watt}$
		1-layer JEDEC test board		301		

Table 3: Electrical specifications

Note 2: Guaranteed by design

Note 3: The sensing propagation delay represents the delay from the magnetic field change ($B > B_{OP}$ or $B < B_{RP}$) to the beginning of the output change.

7 Magnetic Specifications

DC Operating Parameters at $T_A = 25^\circ\text{C}$, $V_{DD} = 3\text{V} / 5\text{V}$ (unless otherwise specified)

Parameter	Symbol	Test Conditions	Min	Typ	Max	Units
Operate point	B_{OP}		0	3	5	mT
Release point	B_{RP}		-5	-3	0	mT
Hysteresis	B_{HYST}		2	6	10	mT

Table 4: Magnetic specifications

8 Outputs Behaviour vs. Magnetic Pole

Parameter	Test conditions	OUT1	OUT2	FG
South pole	$B > B_{OP}$	High	Low	Low
North pole	$B < B_{RP}$	Low	High	High

Table 5: Outputs behaviour vs. magnetic pole

Note : The magnetic pole is applied facing the branded side of the package.

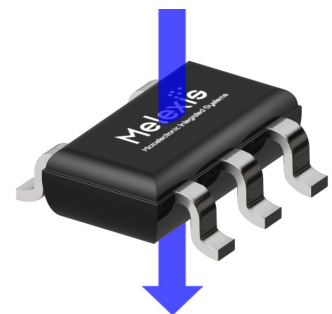

9 Detailed General Description

The US168/169 is an efficient one-chip solution for driving Brushless DC fans and motors. The IC includes Hall-effect sensor, chopping amplifier for offset cancellation, digital control circuitry and full bridge output driver.

The US168 has an open-drain tachometer FG output that follows the Hall signal.

In the US169, the open-drain alarm output RD is active low during normal spinning of the motor. It goes high when the magnetic flux switching frequency drops below nearly 1Hz (30RPM for 2 pole-pair fan).

Reverse voltage protection is integrated on the V_{DD} pin.

The FG/RD open drain output has an internal current limit. It can be activated if a low-ohmic pull-up resistor is used or if the FG/RD output is short connected to a supply voltage.

The built-in locked rotor protection automatically shuts off the coil current when the rotor is mechanically blocked for more than 0.4 second. The fan tries to restart every 2.8 seconds until the rotor is released. This on/off cycling reduces the average current by factor of 7. It is enough to prevent fans from overheating or damage.

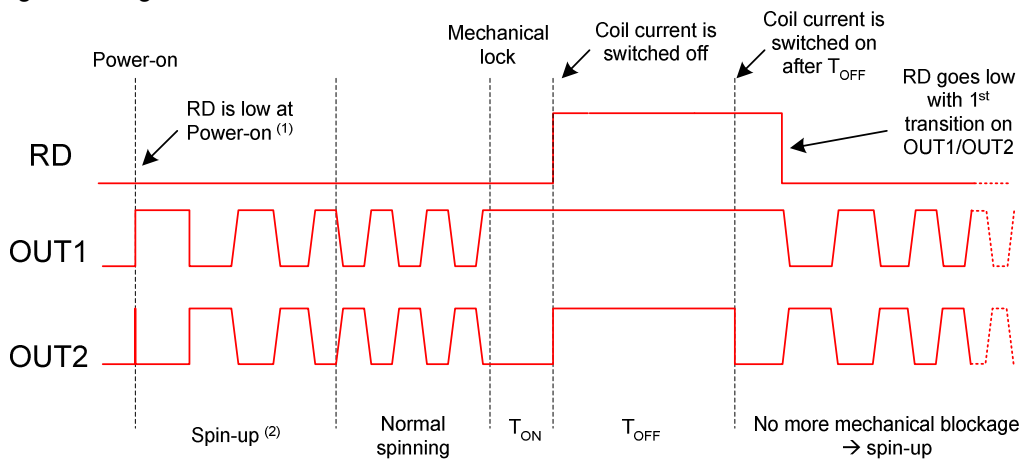

Notes:

1. At Power-on, RD is low. If no transition occurs on OUT1/OUT2 before TON time, RD goes high.
2. The spin-up is the acceleration from the zero speed to maximal speed. It depends on the motor characteristics.
3. Waveform of OUT1 and OUT2 when VDD greater than VDDsw
4. FG (not represented) is high during locked rotor condition

In case the junction temperature T_J exceeds T_{SD} , the thermal protection stops the current flowing through the full bridge by setting the outputs OUT1 and OUT2 low and setting the output FG (RD) high.

The IC stays in this state until the junction temperature decreases below T_{REL} .

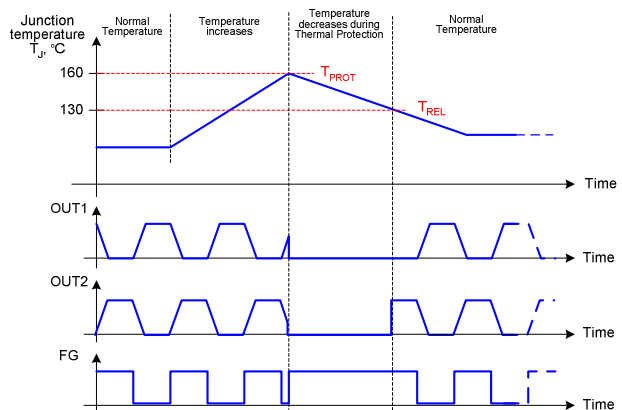

10 Unique Features

The US168/169 provides an efficient solution for low noise applications.

The Soft Switching concept reduces the acoustic and electrical motor noise with a smooth transition of the coil current when V_{DD} is greater than V_{DDsw} .

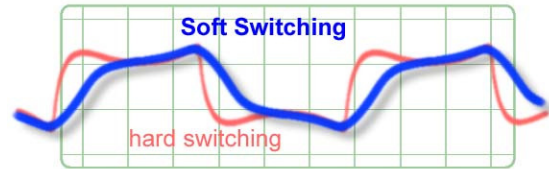

Soft Switching coil current compared to hard switching

The smooth current switching is realized by a precise control of the H-Bridge output voltages, as shown on the figures below:

- (A) $V_{OUT1} > V_{OUT2}$ - the coil current flows from OUT1 to OUT2.
- (B) V_{OUT1} decreases while V_{OUT2} increases, thus reducing smoothly the coil current.
At a certain moment, the coil current equals zero.
 V_{OUT1} further decreases while V_{OUT2} increases, so the coil current starts flowing in the opposite direction.
- (C) $V_{OUT1} < V_{OUT2}$ - the coil current flows from OUT2 to OUT1.

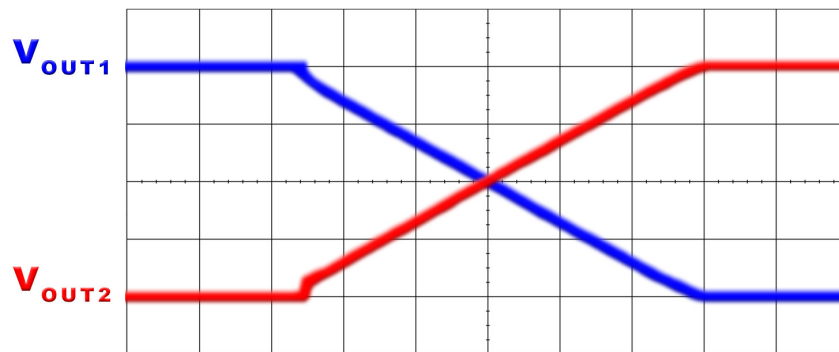

Soft Switching Output Voltages

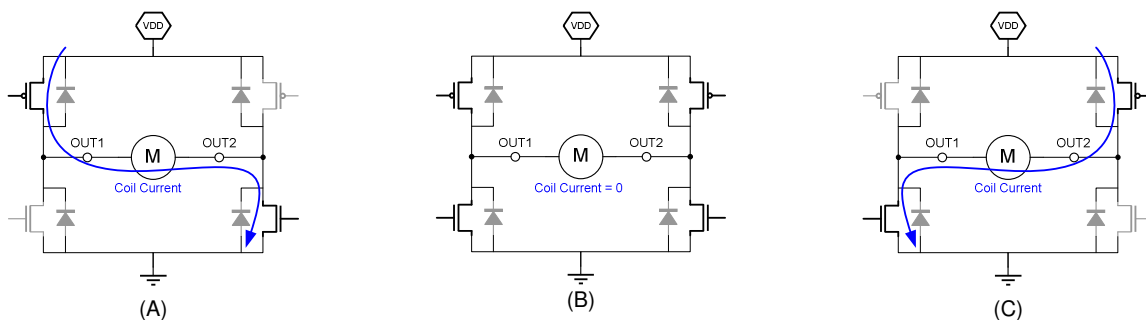

This technique used in a Full Bridge allows producing efficient motor with very low audible noise. Moreover, Soft Switching approach versus traditional hard switching helps reducing the Electro Magnetic Interference (EMI) generated by the coil.

11 Typical Performance Graphs

11.1 R_{ON} vs. T_A

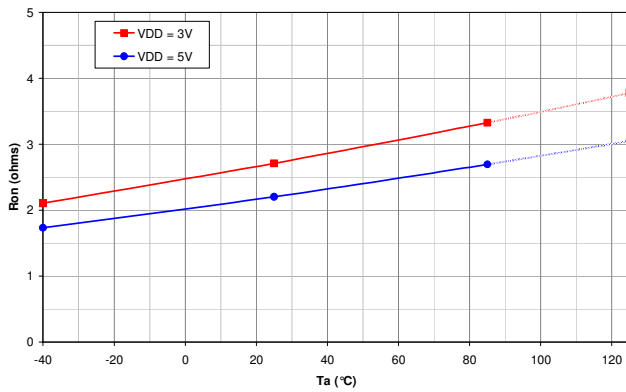

11.2 R_{ON} vs. V_{DD}

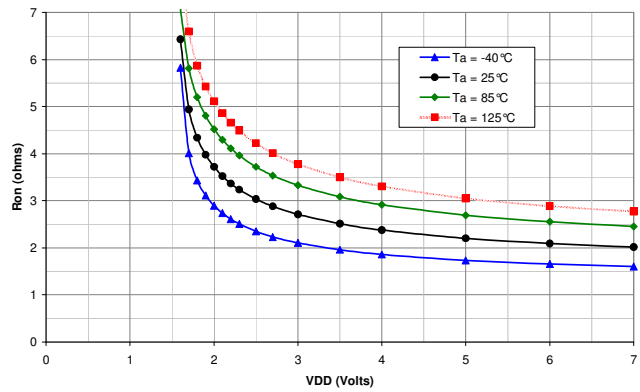

11.3 Magnetic Parameters vs. T_A

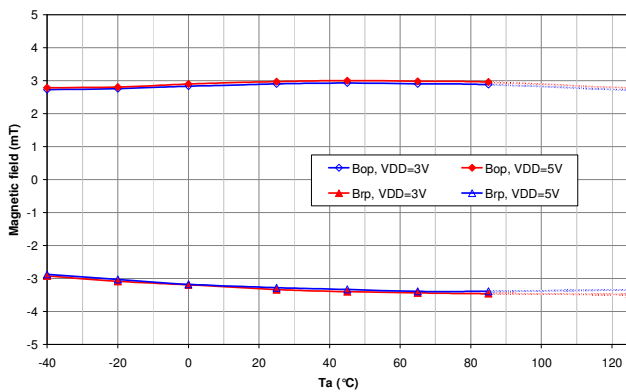

11.4 Magnetic Parameters vs. V_{DD}

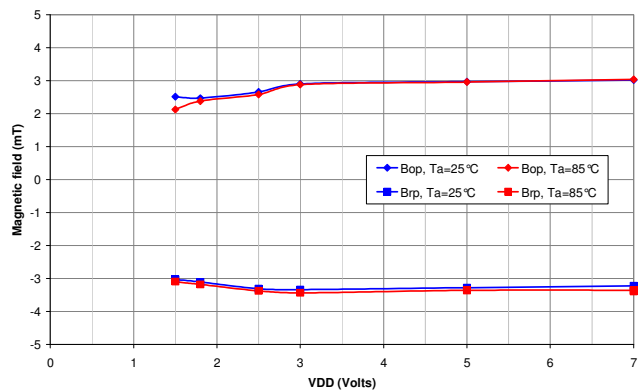

11.5 Slope duration vs. T_A

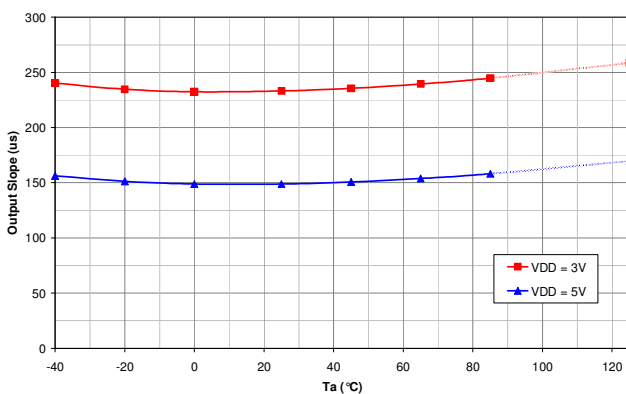

11.6 Slope duration vs. V_{DD}

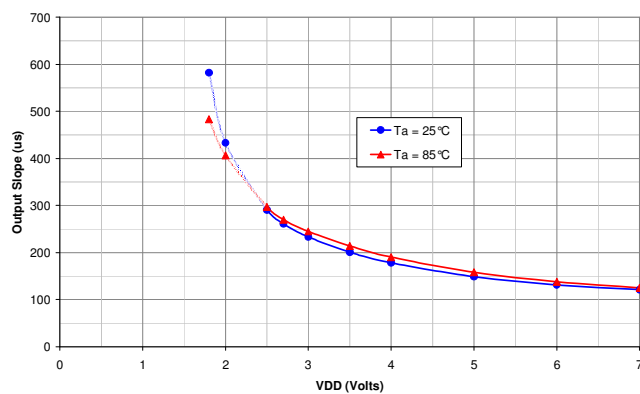

11.7 I_{DD} vs. V_{DD}

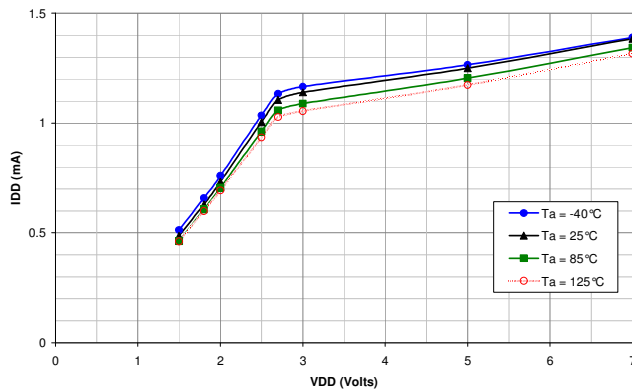

11.8 V_{OL} vs. T_A

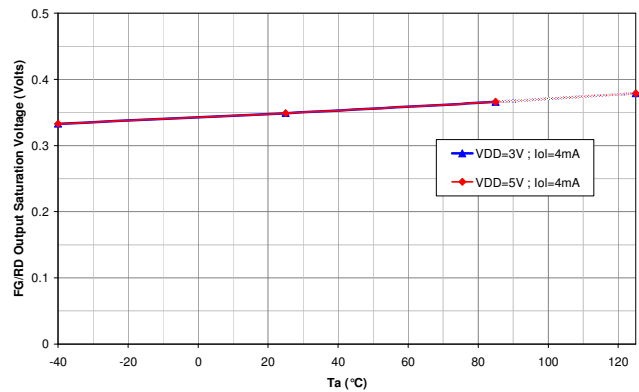

11.9 Power dissipation graph

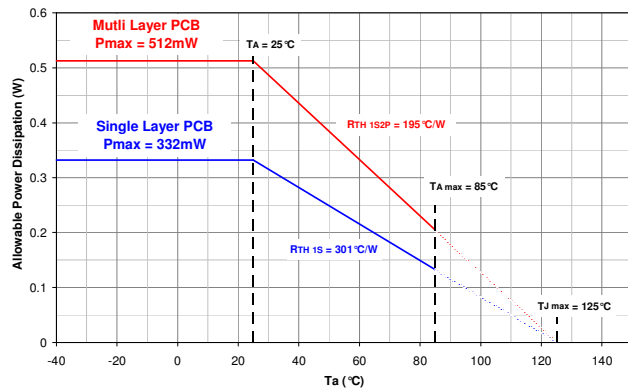

The thermal resistance and rated power dissipation are defined in accordance with EIA/JESD51-3 standard for single layer 1S test board and EIAJESD51-7 standard for multi layer 1S2P test board.

11.10 Recommended maximum continuous output current vs. V_{DD}

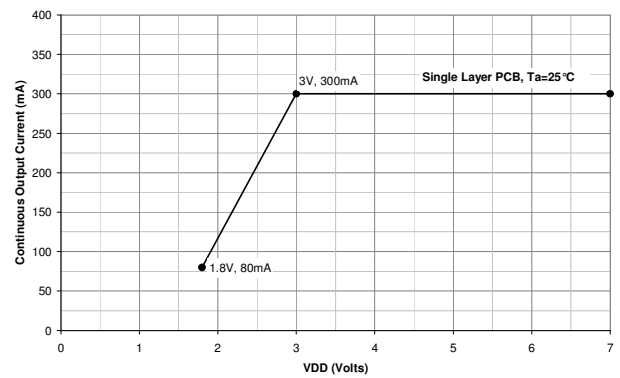

12 Test Circuits

General test principles illustrated in the figures below
DUT = Device Under Test

12.1 Supply Current

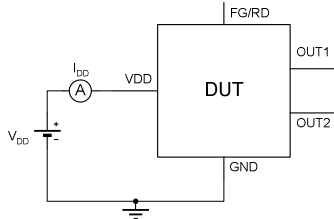

Note 1 - The supply current I_{DD} represents the static supply current. OUT1, OUT2 and FG/RD are left open during measurement.

12.2 Full Bridge ON Resistance

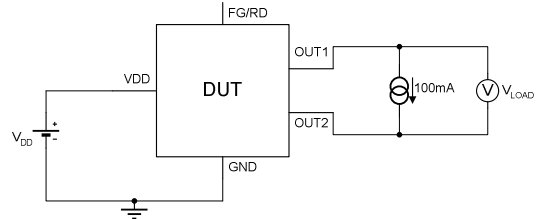

Note 1 - The full bridge output ON resistance R_{ON} is determined by :
 $(V_{DD} - V_{LOAD}) / 100mA$

Note 2 - During the measurement, the junction temperature T_j is close to the ambient temperature T_A

12.3 Output Switching Slope Duration

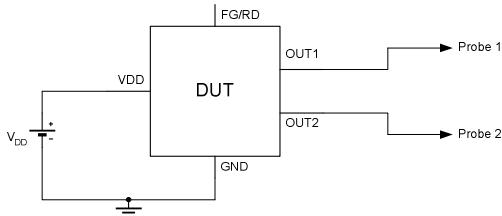

Note 1 - The device is put under a switching magnetic field.

Note 2 - The output slope switching duration is determined by measuring the total rise or fall time from 20% to 80% and extrapolating for the supply voltage V_{DD}

12.4 Soft Switching Threshold Voltage

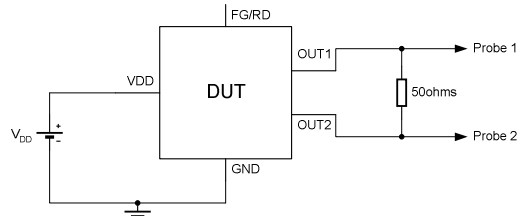

Note 1 - The supply voltage is a ramp-up increasing slowly.

Note 2 - The device is put under a switching magnetic field.

Note 3 - The soft switching threshold voltage is determined when the output rise and fall time exceeds 10us.

12.5 FG/RD Output Low Voltage

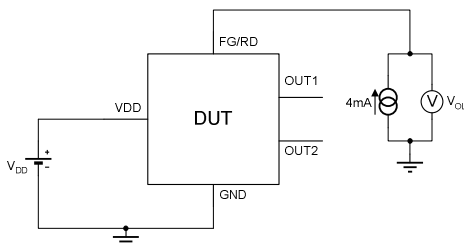

Note 1 - The device is triggered to ensure FG output is low at power-on.

Note 2 - The FG/RD output low voltage is measured during the first T_{ON} period at the power-on event.

12.6 FG/RD Output Current Limit

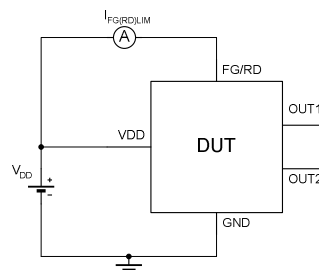

Note 1 - $I_{FG/RD(LIM)}$ is measured when the FG/RD driver is ON.

12.7 FG/RD Output Leakage Current

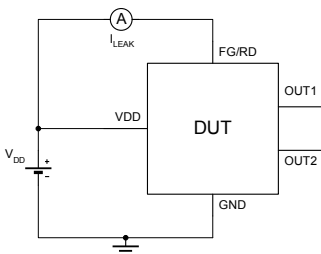

Note 1 - I_{LEAK} is measured when the FG/RD driver is OFF

12.8 Thermal Protection

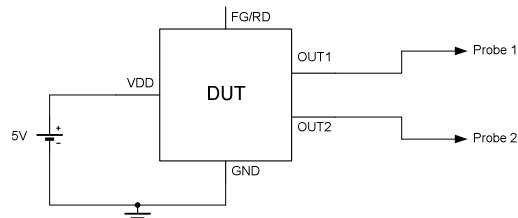

Note 1 - The ambient temperature is slowly increasing/decreasing.

Note 2 - The thermal protection temperatures are determined when the Locked Rotor Protection is disabled (no more switching on the outputs)

13 Application Information

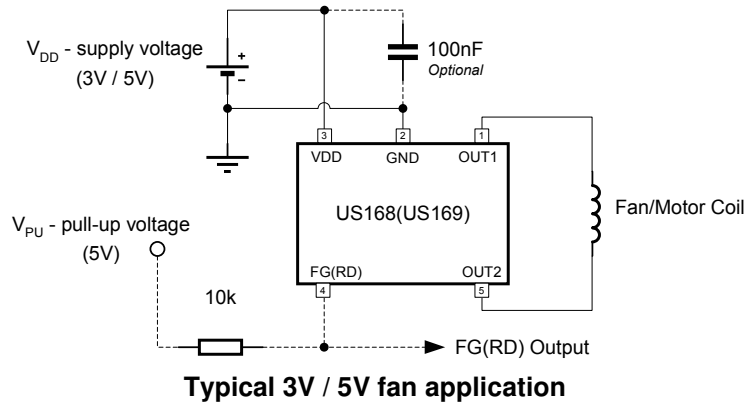

14 Application Comments

The device is designed to work without external components. Application using FG/RD output signal requires a pull-up resistor. The pull-up voltage can be either connected to the supply voltage V_{DD} or to a separate supply voltage V_{PU} . A 100nF decoupling capacitor may be added between V_{DD} and ground to increase stability or protect against external noise and power surge.

The Soft Switching provides the best results when the fan PCB is optimized as well. The location of the Hall sensor with respect to the fan stator slots is important to make an efficient motor with high torque, low power consumption and low noise. Therefore, it is recommended to adapt the fan PCB when using soft switching instead of replacing existing hard switching solution without any PCB redesign.

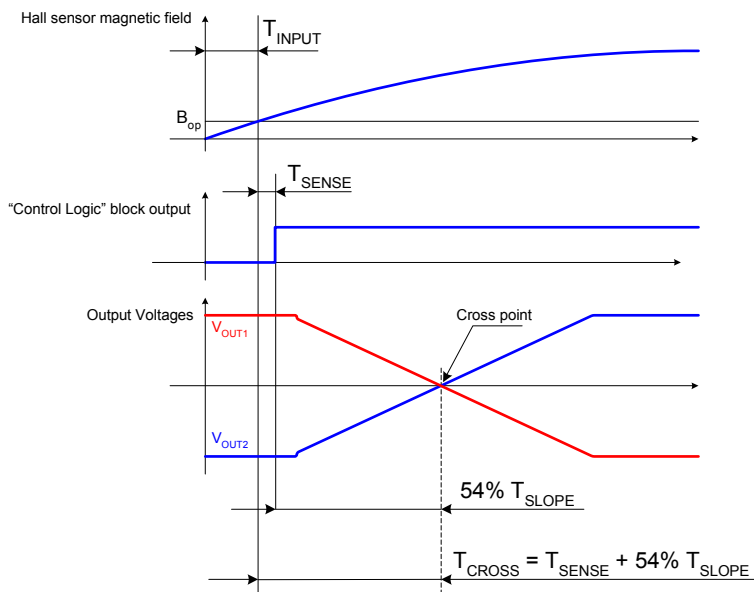

The different IC delays are illustrated on the left figure.

In order to determine the optimum Hall sensor position for a given rotation speed, it is recommended to use the parameters T_{CROSS} (output voltages cross point delay) and the delays related to the motor itself.

T_{CROSS} is the sum of the sensing propagation delay T_{SENSE} and 54% of the output slope duration T_{SLOPE} .

The delays from the motor are T_{INPUT} (delay from zero to magnetic threshold depending on rotor maximum magnetic field) and the motor coil time constant.

15 Standard information regarding manufacturability of Melexis products with different soldering processes

Our products are classified and qualified regarding soldering technology, solderability and moisture sensitivity level according to following test methods:

Reflow Soldering SMD's (Surface Mount Devices)

- IPC/JEDEC J-STD-020
Moisture/Reflow Sensitivity Classification for Nonhermetic Solid State Surface Mount Devices (classification reflow profiles according to table 5-2)
- EIA/JEDEC JESD22-A113
Preconditioning of Nonhermetic Surface Mount Devices Prior to Reliability Testing (reflow profiles according to table 2)

Wave Soldering SMD's (Surface Mount Devices) and THD's (Through Hole Devices)

- EN60749-20
Resistance of plastic- encapsulated SMD's to combined effect of moisture and soldering heat
- EIA/JEDEC JESD22-B106 and EN60749-15
Resistance to soldering temperature for through-hole mounted devices

Iron Soldering THD's (Through Hole Devices)

- EN60749-15
Resistance to soldering temperature for through-hole mounted devices

Solderability SMD's (Surface Mount Devices) and THD's (Through Hole Devices)

- EIA/JEDEC JESD22-B102 and EN60749-21
Solderability

For all soldering technologies deviating from above mentioned standard conditions (regarding peak temperature, temperature gradient, temperature profile etc) additional classification and qualification tests have to be agreed upon with Melexis.

The application of Wave Soldering for SMD's is allowed only after consulting Melexis regarding assurance of adhesive strength between device and board.

Melexis is contributing to global environmental conservation by promoting **lead free** solutions. For more information on qualifications of **RoHS** compliant products (RoHS = European directive on the Restriction Of the use of certain Hazardous Substances) please visit the quality page on our website:

<http://www.melexis.com/quality.aspx>

16 ESD Precautions

Electronic semiconductor products are sensitive to Electro Static Discharge (ESD). Always observe Electro Static Discharge control procedures whenever handling semiconductor products.

17 Package Information

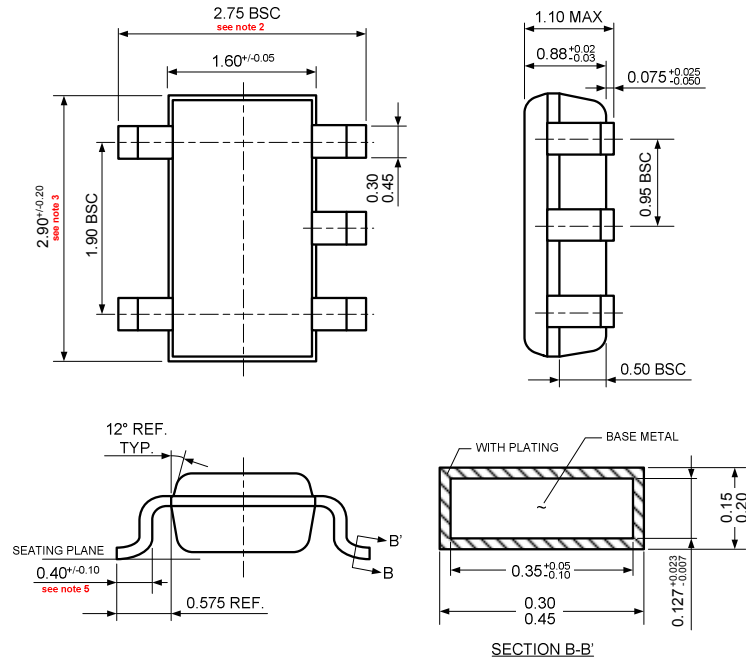

Notes:

1. All dimensions are in millimeters
2. Outermost plastic extreme width does not include mold flash or protrusions. Mold flash and protrusions shall not exceed 0.15mm per side.
3. Outermost plastic extreme length does not include mold flash or protrusions. Mold flash and protrusions shall not exceed 0.25mm per side.
4. The lead width dimension does not include dambar protrusion. Allowable dambar protrusion shall be 0.07mm total in excess of the lead width dimension at maximum material condition.
5. Dimension is the length of terminal for soldering to a substrate.
6. Formed lead shall be planar with respect to one another with 0.076mm at seating plane.
7. This part is compliant with JEDEC specification MO-193. This part is full compliance to EIAJ specification SC-74.

Marking:

Top side: U168 (U169) - Name of the Device

Bottom side: xyww x = last digit of lot number
 y = last digit of year
 ww = week

Hall plate location

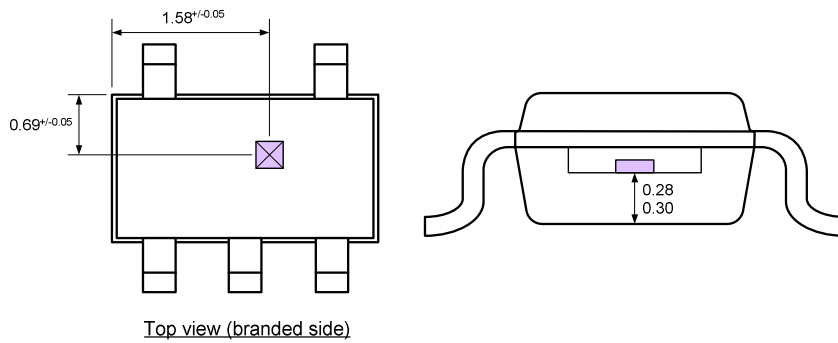

Notes:

1. All dimensions are in millimeters

18 Disclaimer

Devices sold by Melexis are covered by the warranty and patent indemnification provisions appearing in its Term of Sale. Melexis makes no warranty, express, statutory, implied, or by description regarding the information set forth herein or regarding the freedom of the described devices from patent infringement. Melexis reserves the right to change specifications and prices at any time and without notice. Therefore, prior to designing this product into a system, it is necessary to check with Melexis for current information. This product is intended for use in normal commercial applications. Applications requiring extended temperature range, unusual environmental requirements, or high reliability applications, such as military, medical life-support or life-sustaining equipment are specifically not recommended without additional processing by Melexis for each application.

The information furnished by Melexis is believed to be correct and accurate. However, Melexis shall not be liable to recipient or any third party for any damages, including but not limited to personal injury, property damage, loss of profits, loss of use, interrupt of business or indirect, special incidental or consequential damages, of any kind, in connection with or arising out of the furnishing, performance or use of the technical data herein. No obligation or liability to recipient or any third party shall arise or flow out of Melexis' rendering of technical or other services.

© 2005 Melexis NV. All rights reserved.

For the latest version of this document, go to our website at
www.melexis.com

Or for additional information contact Melexis Direct:

Europe and Japan:
Phone: +32 1367 0495
E-mail: sales_europe@melexis.com

All other locations:
Phone: +1 603 223 2362
E-mail: sales_usa@melexis.com

ISO/TS 16949 and ISO14001 Certified