

54, 74 Series GHz Logic

FEATURES:	DESCRIPTION:
<ul style="list-style-type: none"> . Patented technology . Operating frequency up to 1.125GHz with 2pf load . Operating frequency up to 680MHz with 5pf load . Operating frequency up to 300MHz with 15pf load . Operating frequency up to 100MHz with 50pf load . VCC Operates from 1.65V to 3.6V . Propagation delay < 1.8ns max with 15pf load . Low input capacitance: 4pf typical . Available in 14pin 150mil wide SOIC package 	<p>Potato Semiconductor's PO74G14A is designed for world top performance using submicron CMOS technology to achieve 1.125GHz TTL /CMOS output frequency with less than 1.8ns propagation delay. This hex inverter contains six independent inverters designed for 1.65-V to 3.6-V VCC operation. The PO74G14A performs the Boolean function $Y = \overline{A}$. Inputs can be driven from either 3.3V or 5V devices. This feature allows the use of these devices as translators in a mixed 3.3V/5V system environment.</p>

Pin Configuration

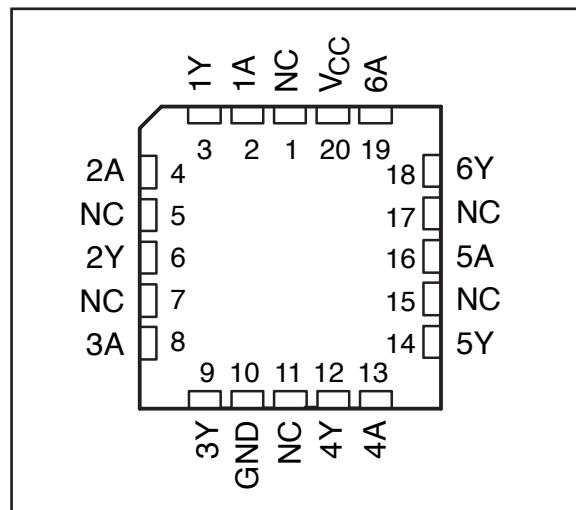
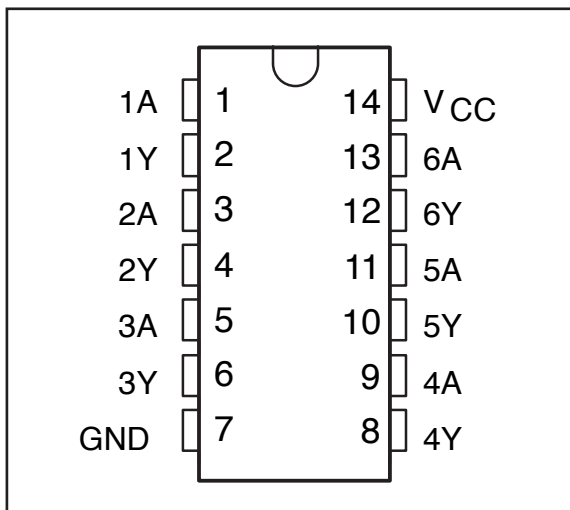

Pin Description

INPUT A	OUTPUT Y
H	L
L	H

Logic Block Diagram

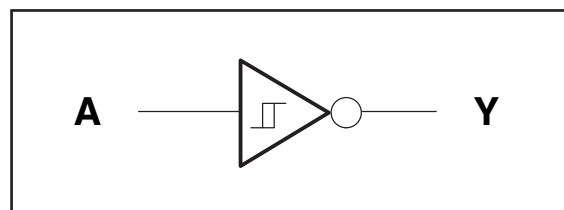

54, 74 Series GHz Logic

Maximum Ratings

Description	Max	Unit
Storage Temperature	-65 to 150	°C
Operation Temperature	-55 to 125	°C
Operation Voltage	-0.5 to +4.6	V
Input Voltage	-0.5 to +5.5	V
Output Voltage	-0.5 to V _{cc} +0.5	V

Note:

stresses greater than listed under Maximum Ratings may cause permanent damage to the device. This is a stress rating only and functional operation of the device at these or any other conditions above those indicated in the operational sections of this specification is not implied. Exposure to absolute maximum rating conditions for extended periods may affect reliability specification is not implied.

DC Electrical Characteristics

Symbol	Description	Test Conditions	Min	Typ	Max	Unit
V_{OH}	Output High voltage	V _{cc} =3V Vin=V _{IH} or V _{IL} , I _{OH} = -12mA	2.4	3	-	V
V_{OL}	Output Low voltage	V _{cc} =3V Vin=V _{IH} or V _{IL} , I _{OH} =12mA	-	0.3	0.5	V
V_{IH}	Input High voltage	Guaranteed Logic HIGH Level (Input Pin)	2	-	5.5	V
V_{IL}	Input Low voltage	Guaranteed Logic LOW Level (Input Pin)	-0.5	-	0.8	V
I_{IH}	Input High current	V _{cc} = 3.6V and Vin = 5.5V	-	-	5	uA
I_{IL}	Input Low current	V _{cc} = 3.6V and Vin = 0V	-	-	-5	uA
V_{IK}	Clamp diode voltage	V _{cc} = Min. And I _{IN} = -18mA	-	-0.7	-1.2	V

Notes:

1. For conditions shown as Max. or Min., use appropriate value specified under Electrical Characteristics for the applicable device type.
2. Typical values are at V_{cc} = 3.3V, 25 °C ambient.
3. This parameter is guaranteed but not tested.
4. Not more than one output should be shorted at one time. Duration of the test should not exceed one second.
5. V_{oH} = V_{cc} - 0.6V at rated current

54, 74 Series GHz Logic

Power Supply Characteristics

Symbol	Description	Test Conditions (1)	Min	Typ	Max	Unit
IccQ	Quiescent Power Supply Current	Vcc=Max, Vin=Vcc or GND	-	0.1	30	uA
ΔIcc	Power Supply Current per Input High	Vcc=Max, Vin= Vcc-0.6V	-	50	300	uA

Notes:

1. For conditions shown as Max. or Min., use appropriate value specified under Electrical Characteristics for the applicable device type.
2. Typical values are at Vcc = 3.3V, 25°C ambient.
3. This parameter is guaranteed but not tested.
4. Not more than one output should be shorted at one time. Duration of the test should not exceed one second.
5. VoH = Vcc – 0.6V at rated current

Capacitance

Parameters (1)	Description	Test Conditions	Typ	Unit
Cin	Input Capacitance	Vin = 0V	4	pF
Cout	Output Capacitance	Vout = 0V	6	pF

Notes:

- 1 This parameter is determined by device characterization but not production tested.

Switching Characteristics

Symbol	Description	Test Conditions (1)	Max	Unit
tPLH	Propagation Delay A to Y	CL = 15pF	1.8	ns
tPHL	Propagation Delay A to Y	CL = 15pF	1.8	ns
tr/tf	Rise/Fall Time	0.8V – 2.0V	0.8	ns
fmax	Input Frequency	CL = 50pF	100	MHz
fmax	Input Frequency	CL = 15pF	300	MHz
fmax	Input Frequency	CL = 5pF	680	MHz
fmax	Input Frequency	CL = 2pF	1125	MHz

Notes:

1. See test circuits and waveforms.
2. tPLH, tPHL, tsk(p), and tsk(o) are production tested. All other parameters guaranteed but not production tested.
3. Airflow of 1m/s is recommended for frequencies above 133MHz

54, 74 Series GHz Logic

Test Waveforms

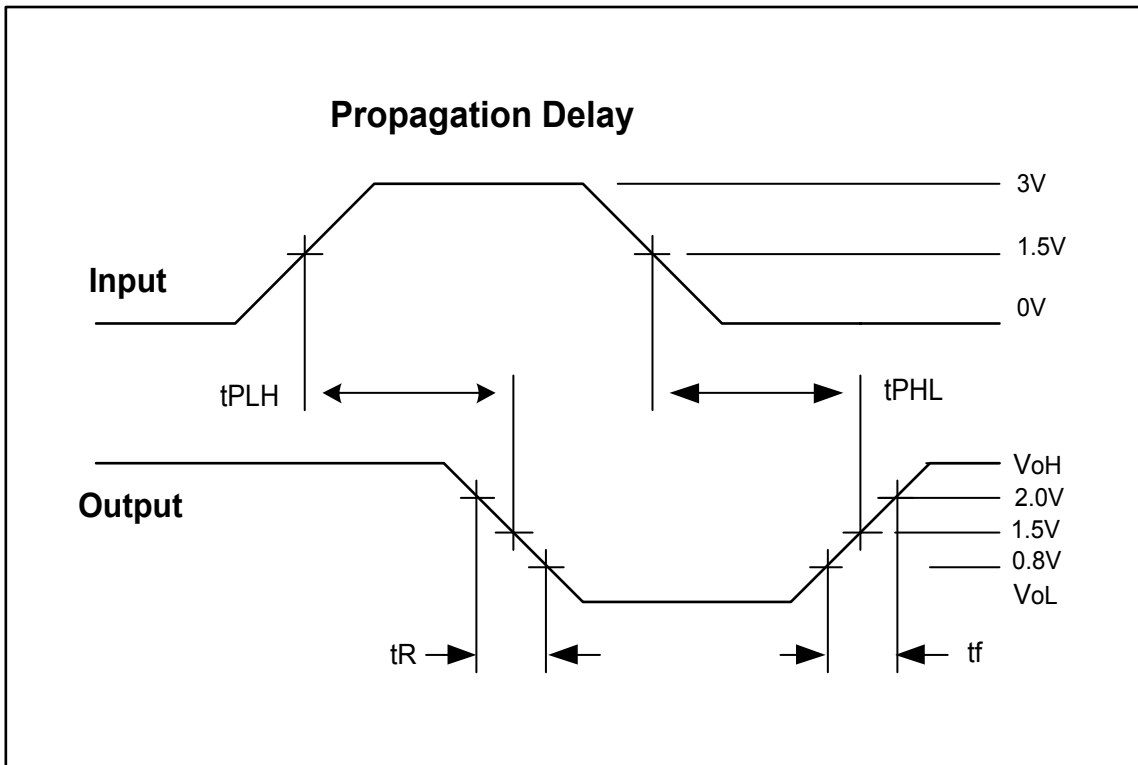

Test Circuit

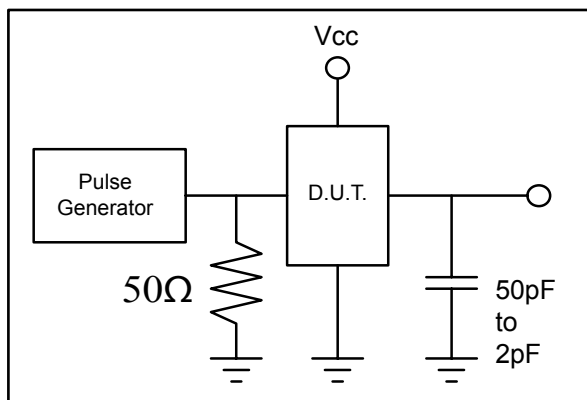

54, 74 Series GHz Logic

Packaging Mechanical Drawing: 20pin Ceramic Dual Flatpack

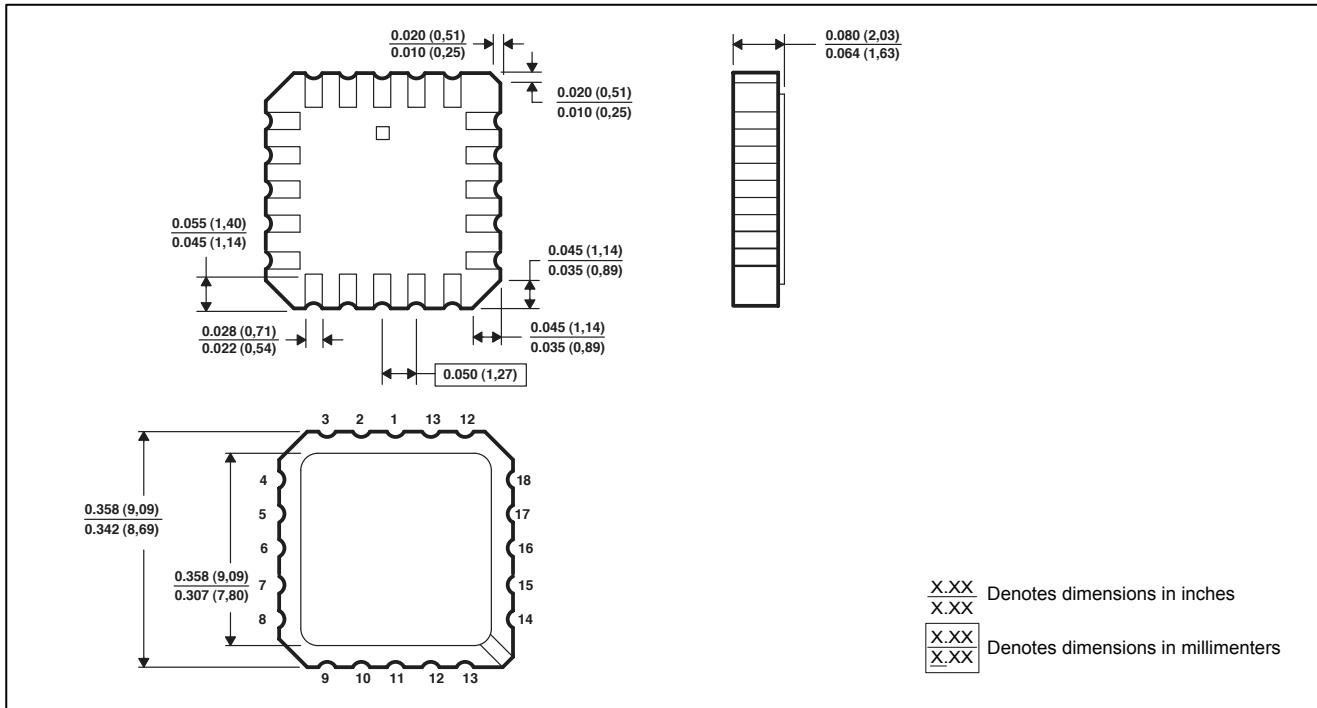

Ordering Information

Ordering Code	Package			Top-Marking	T _A
PO74G14ASU	14pin SOIC	Tube	Pb-free & Green	PO74G14AS	-40°C to 85°C
PO74G14ASR	14pin SOIC	Tape and reel	Pb-free & Green	PO74G14AS	-40°C to 85°C
PO74G14ASiU	14pin SOIC	Tube	Pb-free & Green	PO74G14ASi	-40°C to 125°C
PO74G14ASiR	14pin SOIC	Tape and reel	Pb-free & Green	PO74G14ASi	-40°C to 125°C
PO54G14ALU	14pin Leadless Ceramic Chip Carrier	Tube	Pb-free & Green	PO54G14AL	-55°C to 125°C
PO54G14AFU	20pin Ceramic Dual Flatpack	Tube	Pb-free & Green	PO54G14AF	-55°C to 125°C

IC Package Information

PACKAGE CODE	PACKAGE TYPE	TAPE WIDTH (mm)	TAPE PITCH (mm)	PIN 1 LOCATION	TAPE TRAILER LENGTH	QTY PER REEL	TAPE LEADER LENGTH	QTY PER TUBE
S	SOIC 14	16	8	Top Left Corner	39 (12")	3000	64 (20")	55
L	LCCC 20	N/A	N/A	N/A	N/A	N/A	N/A	55
F	CFP 14	N/A	N/A	N/A	N/A	N/A	N/A	150