

**1M x 16Bit x 4 Banks synchronous DRAM****GENERAL DESCRIPTION**

The TBS6416B4E is 67,108,864 bits synchronous high data rate Dynamic RAM organized as 4 x 1,048,576 words by 16 bits, fabricated with M'tec high performance CMOS technology. Synchronous design allows precise cycle control with the use of system clock I/O transactions are possible on every clock cycle. Range of operating frequencies, programmable burst length and programmable latencies allow the same device to be useful for a variety of high bandwidth, high performance memory system applications.

**FEATURES**

- JEDEC standard 3.3V power supply
- LVTTTL compatible with multiplexed address
- Four-banks operation
- MRS cycle with address key programs
  - . CAS latency (2 & 3)
  - . Burst length (1, 2, 4, 8 & Full page)
  - . Burst type (Sequential & Interleave)
- All inputs are sampled at the positive going edge of the system clock.
- Burst read single-bit write operation
- DQM for masking
- Auto & self refresh
- 64ms refresh period (4K cycle)

**ORDERING INFORMATION**

Part No.	Max Freq.	Interface	Package
TBS6416B4E-7G	143MHz	LVTTTL	54 TSOP(II)

## PIN CONFIGURATION (Top View)

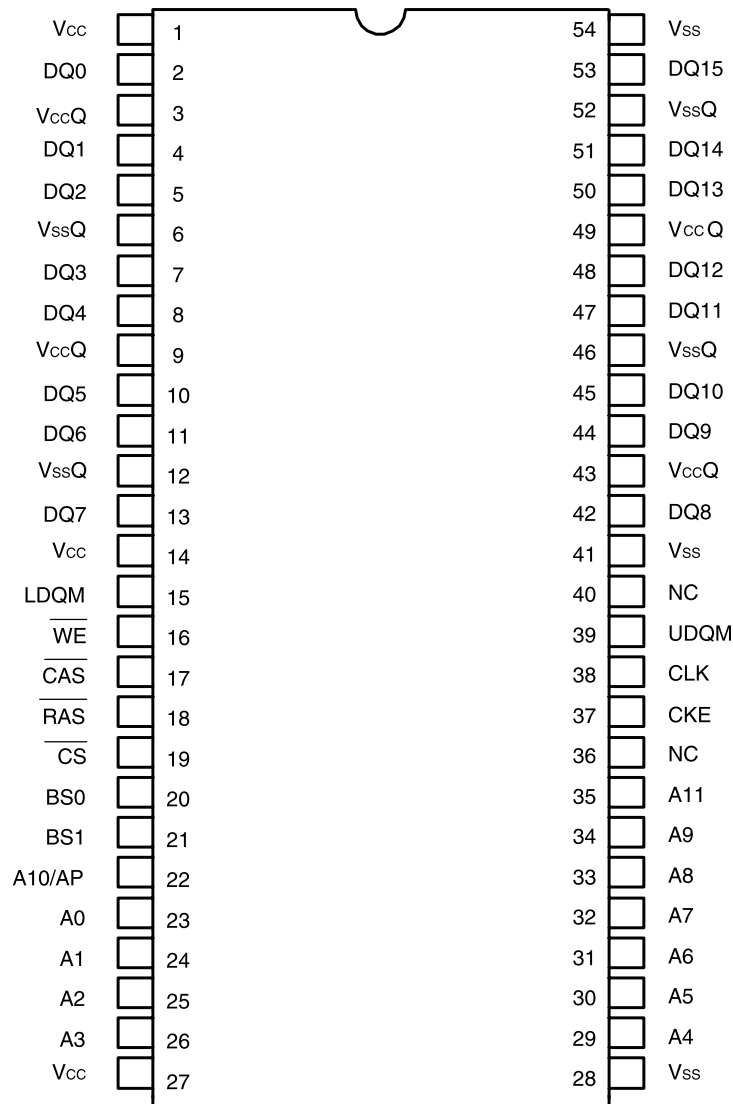

**54Pin TSOP (II)**  
**(400mil x 875mil)**  
**(0.8 mm Pin pitch)**

## PIN FUNCTION DESCRIPTION

Pin Name	Function	Description
A0~ A11	Address	Multiplexed pins for row and column address Row address: A0~ A11. Column address: A0 ~ A7.
BS0, BS1	Bank	Select bank to activate during row address latch time, or bank to read/write during address latch time.
DQ0 ~DQ15	Data Input / Output	Multiplexed pins for data output and input.
/CS	Chip Select	Disable or enable the command decoder. When command decoder is disabled, new command is ignored and previous operation continues.
/RAS	Row Address Strobe	Command input. When sampled at the rising edge of the clock, /RAS, /CAS and /WE define the operation to be executed.
/CAS	Column Address Strobe	Referred to /RAS
/WE	Write Enable	Referred to /RAS
UDQM/LDQM	Input /output mask	The output buffer is placed at Hi-Z (with latency of 2) when DQM is sampled high in read cycle. In write cycle, sampling DQM high will block the write operation with zero latency.
CLK	Clock Input	System clock used to sample inputs on the rising edge of clock.
CKE	Clock Enable	CKE controls the clock activation and deactivation. When CKE is low, Power Down mode, Suspend mode, or Self Refresh mode is entered.
Vcc	Power (+3.3 V)	Power for input buffers and logic circuit inside DRAM.
Vss	Ground	Ground for input buffers and logic circuit inside DRAM.
Vcc	Q Power (+ 3.3 V) for I/O buffer	Separated power from $v_{cc}$ , used for output buffers to improve noise.
Vss	Q Ground for I/O buffer	Separated ground from $v_{ss}$ , used for output buffers to improve noise.
NC	No Connection	No connection

## FUNCTIONAL BLOCK DIAGRAM

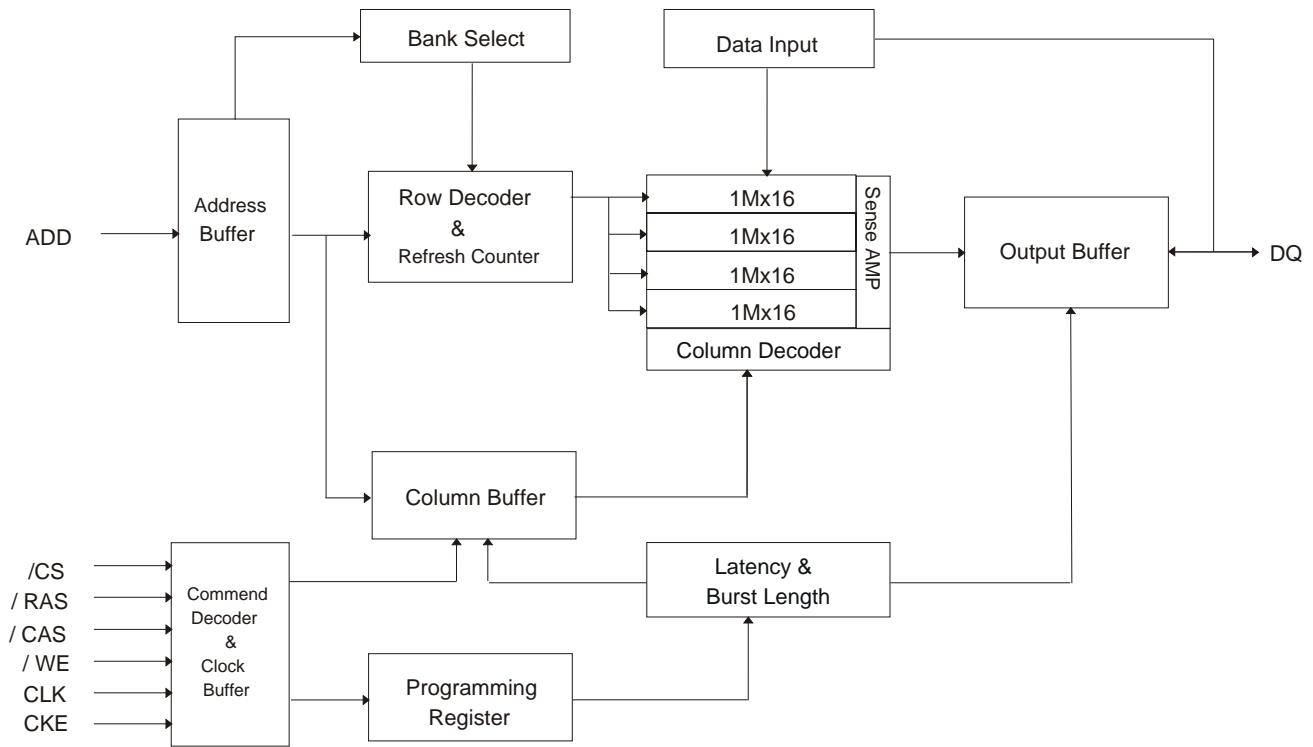

## ABSOLUTE MAXIMUM RATING

Parameter	Symbol	Value	Unit
Voltage on any pin relative to Vss	V <sub>IN</sub> , V <sub>OUT</sub>	-1.0 ~ 4.6	V
Voltage on VCC supply relative to Vss	VCC, VCC <sub>Q</sub>	-1.0 ~ 4.6	V
Storage temperature	T <sub>STG</sub>	-55 ~ +150	°C
Power dissipation	P <sub>D</sub>	1	W
Short circuit current	I <sub>OS</sub>	50	mA

### Note:

Permanent device damage may occur if "ABSOLUTE MAXIMUM RATINGS" are exceeded.

Functional operation should be restricted to the recommended operating conditions.

Exposure to higher voltage than recommended for extended periods of time could affect device reliability.

## DC OPERATING CONDITIONS

Recommended operating conditions (Voltage referenced to Vss = 0V, T<sub>A</sub> = 0 to 70°C)

Parameter	Symbol	Min	Typ	Max	Unit	Note
Supply voltage	VCC, VCC <sub>Q</sub>	3.0	3.3	3.6	V	
Input logic high voltage	V <sub>IH</sub>	2.0	3.0	VCC <sub>Q</sub> +0.3	V	1
Input logic low voltage	V <sub>IL</sub>	-0.3	0	0.8	V	2
Output logic high voltage	V <sub>OH</sub>	2.4	-	-	V	I <sub>OH</sub> =-2mA
Output logic low voltage	V <sub>OL</sub>	-	-	0.4	V	I <sub>OL</sub> =2mA
Input leakage current (Input)	I <sub>IL</sub>	-1	-	1	μA	3
Input leakage current (I/O pins)	I <sub>IL</sub>	-1.5	-	1.5	μA	3,4

### Notes:

1. V<sub>IH</sub> (max) = 5.6V AC. The overshoot voltage duration is  $\leq$  3ns.

2. V<sub>IL</sub> (min) = -2.0V AC. The undershoot voltage duration is  $\leq$  3ns.

3. Any input  $0V \leq V_{IN} \leq VCC_Q$ ,

Input leakage currents include Hi-Z output leakage for all bi-directional buffers with Tri-State outputs.

4. D<sub>out</sub> is disabled,  $0V \leq V_{out} \leq VCC_Q$

## DC CHARACTERISTICS

(Recommended operating condition unless otherwise noted, TA = 0 to 70°C)

Parameter	Symbol	Test Condition	TBS6416B4E-7G	Unit	Note	
Operating current (One bank active)	I <sub>CC1</sub>	Burst length = 1 t <sub>RC</sub> ≥ t <sub>RC</sub> (min) I <sub>OL</sub> = 0mA	100	mA	1	
Pre-charge standby current in power- down mode	I <sub>CC2P</sub>	CKE ≤ V <sub>IL</sub> (max), t <sub>CC</sub> = 15 ns	2	mA		
	I <sub>CC2PS</sub>	CKE&CLK ≤ V <sub>IL</sub> (max), t <sub>CC</sub> = ∞	2			
Pre-charge standby current in non power-down mode	I <sub>CC2N</sub>	CKE ≥ V <sub>IH</sub> (min), /CS ≥ V <sub>IH</sub> (min) , t <sub>CC</sub> = 15ns Input signals are stable	30	mA		
	I <sub>CC2NS</sub>	CKE ≥ V <sub>IH</sub> (min), CLK ≤ V <sub>IL</sub> (Max) , t <sub>CC</sub> = ∞ Input signals are stable	10			
Active standby current in power-down mode	I <sub>CC3P</sub>	CKE ≤ V <sub>IL</sub> (max), t <sub>CC</sub> = 15 ns	5	mA		
	I <sub>CC3PS</sub>	CKE&CLK ≤ V <sub>IL</sub> (max), t <sub>CC</sub> = ∞	5			
Active standby current in non power-down mode (One bank active)	I <sub>CC3N</sub>	CKE ≥ V <sub>IH</sub> (min), /CS ≥ V <sub>IH</sub> (min) , t <sub>CC</sub> = 15ns Input signals are stable	40	mA		
	I <sub>CC3NS</sub>	CKE ≥ V <sub>IH</sub> (min), CLK ≤ V <sub>IL</sub> (Max) , t <sub>CC</sub> = ∞ Input signals are stable	20			
Operating current (Burst mode)	I <sub>CC4</sub>	I <sub>OL</sub> =0 mA Page burst 2Banks activated t <sub>CCD</sub> = 2CLKs	CL = 3	150	mA	1
			CL = 2	140		
Refresh current	I <sub>CC5</sub>	t <sub>RC</sub> ≥ t <sub>RC</sub> (min)	160	mA	2	
Self refresh current	I <sub>CC6</sub>	CKE ≤ 0.2V	1	mA		

**Note:** 1.Measured with outputs open.

2.Refresh period is 64 ms.

**AC CHARACTERISTICS AND OPERATING CONDITION FOR PC-143**(V<sub>cc</sub>=3.3V±0.3V, T<sub>a</sub>=0° to 70°C)

Parameter	Symbol	TBS6416B4E-7G		Unit
		Min	Max	
Row active to row active delay	tRRD	14		ns
/RAS to /RAS delay	tRCD	20		ns
Row pre-charge time	tRP	20		ns
Row active time	tRAS	45	100K	ns
Row cycle time	tRC	63		ns
Col. Address to col. Address delay	tCCD	1		CLK
Write Recovery Time	tWR	14	1000	ns
CLK Cycle Time	tCK	CL=2	10	ns
		CL=3	7	
CLK High Level width	tCH	2.5		ns
CLK Low Level width	tCL	2.5		ns
Access Time from CLK	tAC	CL=2	6	ns
		CL=3	5.4	
Output Data Hold Time	tOH	2.5		ns
Data-in Set-up Time	tDS	1.5		ns
Data-in Hold Time	tDH	1		ns
Address Set-up Time	tAS	1.5		ns
Address Hold Time	tAH	1		ns
CKE Set-up Time	tCKS	1.5		ns
CKE Hold Time	tCKH	1		ns
Command Set-up Time	tCMS	1.5		ns
Command Hold Time	tCMH	1		ns
Refresh Time	tREF		64	ms
Mode register Set Cycle Time	tRSC	15		ns

54PIN PLASTIC TSOP(II) (400mil)

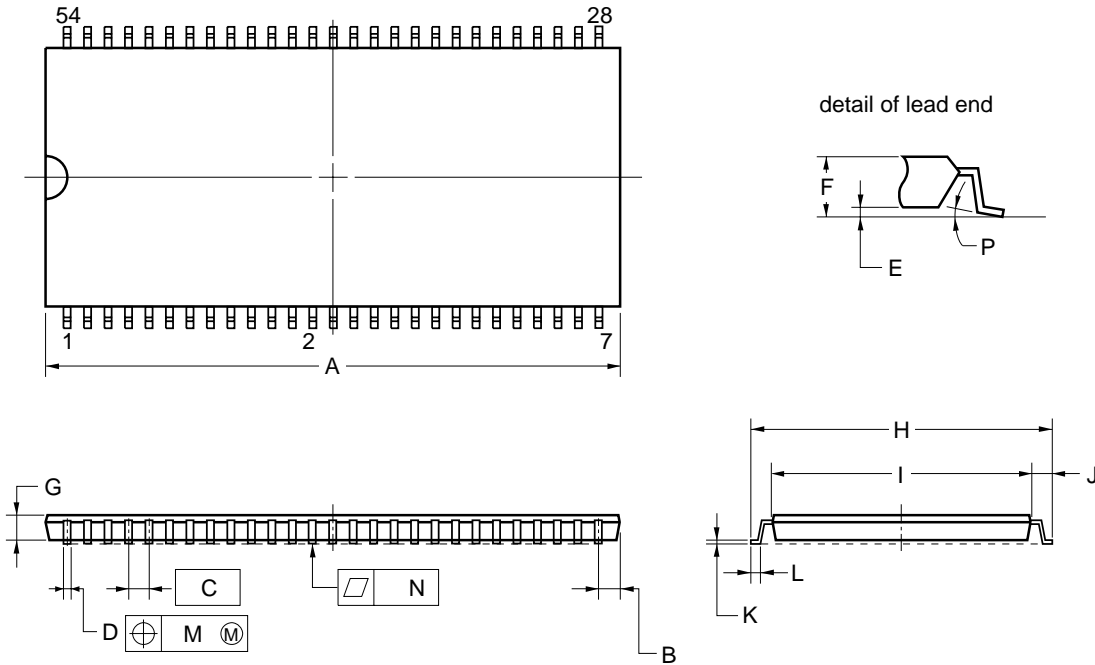

**NOTE**

Each lead centerline is located within 0.13 mm (0.005 inch) of its true position (T.P.) at maximum material condition.

ITEM	MILLIMETERS	INCHES
A	22.62 MAX.	0.891 MAX.
B	0.91 MAX.	0.036 MAX.
C	0.80 (T.P.)	0.031 (T.P.)
D	0.32 <sup>+0.08</sup> <sub>-0.07</sub>	0.013±0.003
E	0.10±0.05	0.004±0.002
F	1.20 MAX.	0.048 MAX.
G	1.00	0.039
H	11.76±0.20	0.463±0.008
I	10.16±0.10	0.400±0.004
J	0.80±0.20	0.031 <sup>+0.009</sup> <sub>-0.008</sub>
K	0.145 <sup>+0.025</sup> <sub>-0.015</sub>	0.006±0.001
L	0.50±0.10	0.020 <sup>+0.004</sup> <sub>-0.005</sub>
M	0.13	0.005
N	0.10	0.004
P	3° <sup>+7°</sup> <sub>-3°</sub>	3° <sup>+7°</sup> <sub>-3°</sub>