



# Technical Data Sheet

## Warm White POWER LED

### 40-01/X4C-4NQB

#### Features

- . High Flux Output.
- . Low Profile.
- . Low Thermal Resistance.
- . Low Power Consumption
- . The phosphor filled in the reflector converts the blue emission of InGaN chip to warm white.
- . The product itself will remain within RoHS compliant version.
- . Wide viewing angles 115°
- . Typical chromaticity coordinates  $x=0.45$ ,  $y=0.41$  according to CIE1931.
- . ESD-withstand voltage: up to 4KV

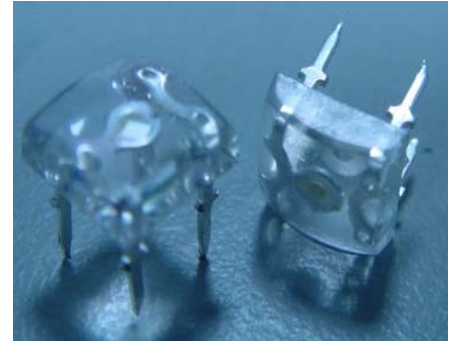

#### Descriptions

This revolutionary package design allows the light designer to reduce the number of LEDs required and provide a more uniform and unique illuminated appearance than with other LED solutions. This is possible through the efficient optical package design and high-current capabilities.

The low profile package can be easily coupled with reflectors or lenses to efficiently distribute light and provide the desired light appearance.

#### Applications

- . Automotive Exterior Lighting
- . Electronic Signs and Signals
- . Special Lighting application

#### Device Selection Guide

PART NO.	Chip		Lens Color
	Material	Emitted Color	
40-01/X4C-4NQB	InGaN	White	Water Clear



# Technical Data Sheet

## Warm White POWER LED

**40-01/X4C-4NOB**

### Package Dimensions

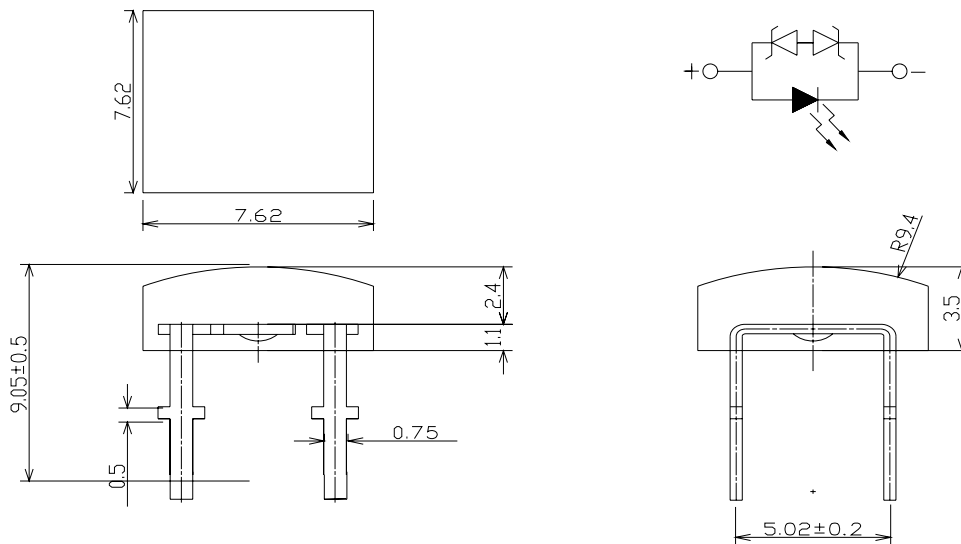

**Notes:** 1.All dimensions are in millimeters

2.An epoxy meniscus may extend about 1.5mm(0.059") down the leads

3.Tolerances unless dimensions  $\pm 0.25\text{mm}$

### Absolute Maximum Ratings (Ta=25°C)

Parameter	Symbol	Rating	Units
Continuous Forward Current	$I_F$	30	mA
Peak Forward Current(Duty 1/10 @ 1KHZ)	$I_{FP}$	100	mA
Reverse Voltage	$V_R$	5	V
Operating Temperature	$T_{opr}$	-40 ~ +85	°C
Storage Temperature	$T_{stg}$	-40 ~ +100	°C
Soldering Temperature(T=5 sec)	$T_{sol}$	260 ± 5	°C
Power Dissipation	$P_d$	100	mW
Zener Reverse Current	$I_z$	100	mA
Electrostatic Discharge	ESD	4000	V



# Technical Data Sheet

## Warm White POWER LED

**40-01/X4C-4NQB**

### Electro-Optical Characteristics (Ta=25°C)

Parameter	Symbol	Min.	Typ.	Max.	Condition	Unit
Forward Voltage	V <sub>F</sub>	3.0	3.6	4.0	I <sub>F</sub> =30mA	V
Reverse Current	I <sub>R</sub>	----	----	10	V <sub>R</sub> =5V	mA
Total Flux	Φ <sub>v</sub>	2250	3200	4500	I <sub>F</sub> =30mA	mlm
Viewing Angle	2θ 1/2	----	115	----	I <sub>F</sub> =30mA	deg
Chromaticity Coordinates	x	----	0.45	----	I <sub>F</sub> =30mA	----
	y	----	0.40	----		----
Zener Reverse Voltage	V <sub>Z</sub>	5.2	----	----	I <sub>Z</sub> =5mA	V
Electrostatic Discharge	ESD	4000	----	----	Human Body Model	V

### Rank

40-01/X4C-4NQB

(1)

(2)

(3)

(1) V <sub>F</sub> (V)			(2) Color			(3) Φ <sub>v</sub> (mlm)		
Bin.	Min.	Max.	Bin.	Min.	Max.	Bin.	Min.	Max.
1	3.00	3.20	E1	----	----	N	2250	2850
2	3.20	3.40	E2	----	----	P	2850	3600
3	3.40	3.60	F1	----	----	Q	3600	4500
4	3.60	3.80	F2	----	----			
5	3.80	4.00						

\*Measurement Uncertainty of Forward Voltage : ±0.1V

\*Measurement Uncertainty of Luminous Intensity: ±15%



# Technical Data Sheet

## Warm White POWER LED

**40-01/X4C-4NQB**

### CIE Chromaticity Diagram

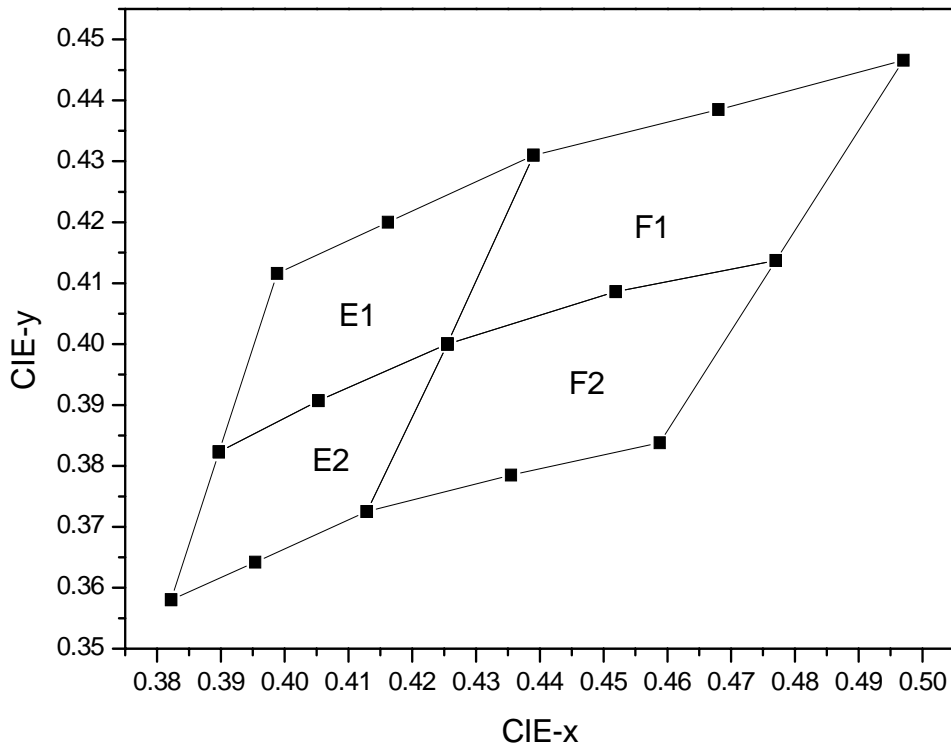

### Color Ranks (IF=30mA , Ta=25°C)

Color Ranks		CIE			
E1	X	0.389	0.398	0.439	0.425
	Y	0.382	0.411	0.431	0.400
E2	X	0.382	0.389	0.425	0.412
	Y	0.358	0.382	0.400	0.372
F1	X	0.425	0.439	0.497	0.477
	Y	0.400	0.431	0.466	0.413
F2	X	0.412	0.425	0.477	0.458
	Y	0.372	0.400	0.413	0.383

\*Measurement uncertainty of the color coordinates : ±0.01



# Technical Data Sheet

## Warm White POWER LED

**40-01/X4C-4NOB**

### Typical Electro-Optical Characteristics Curves

**Relative Intensity vs. Wavelength**

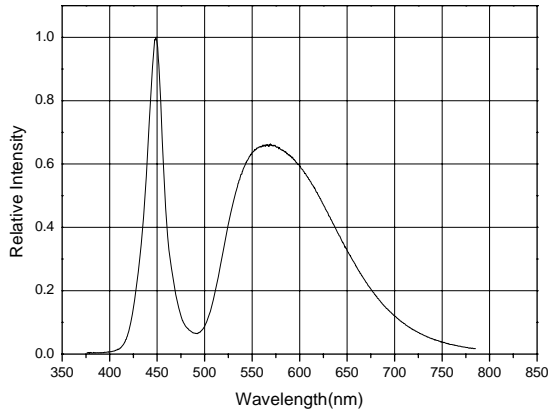

**Forward Current vs. Forward Voltage**

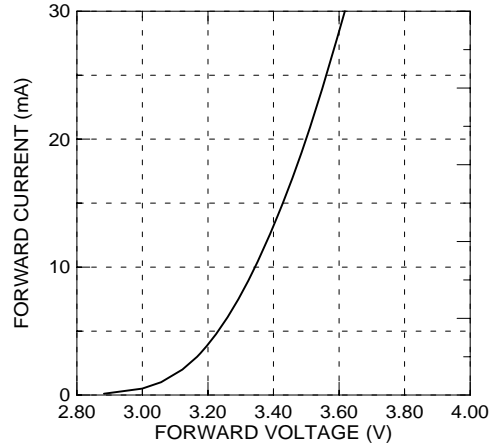

**Relative Intensity vs. Forward Current**

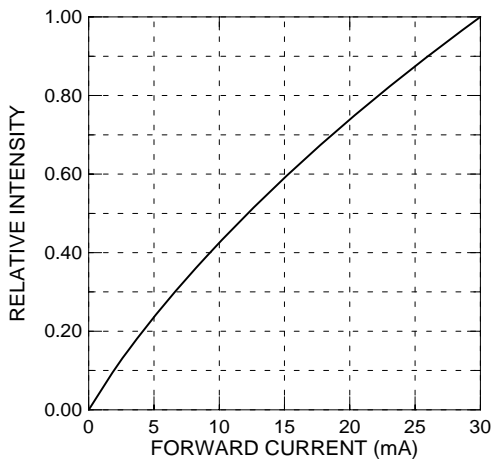

**Forward Current vs. Ambient Temp.**

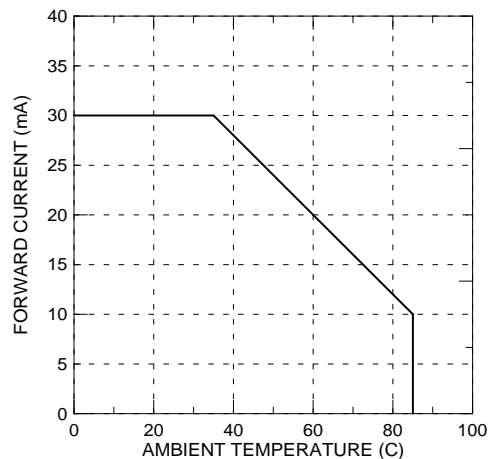

**Chromaticity Coordinate vs. Forward Current**

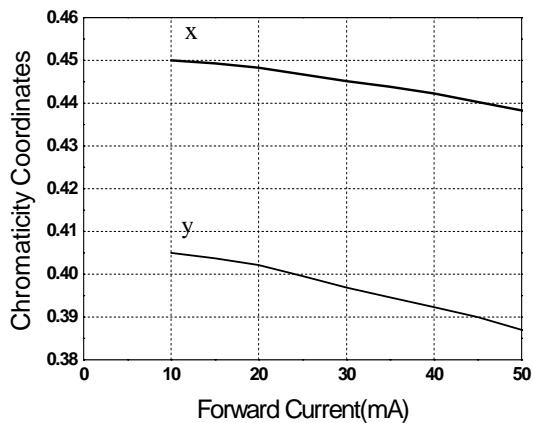

**Radiation Characteristics**

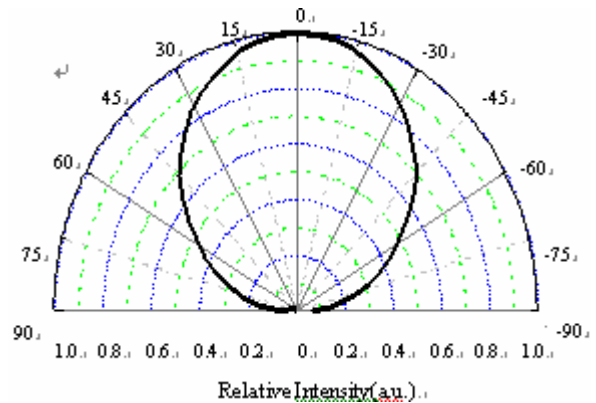



# Technical Data Sheet

## Warm White POWER LED

**40-01/X4C-4NQB**

### Packing Quantity Specification

- (1) 60 pcs/1 tube, 30 tubes/1 small inside box, 12 small inside boxes/1 outside box
- (2) 60 pcs/1 tube, 105 tubes/1 big inside box, 4 big inside boxes/1 outside box

### Label Form Specification

(1) Tube Label Form

	PART NO: 40-01/X4C-4NQB	QTY: 60
	LOT NO:	CAT:

(2) Box Label Form

CPN:	
P/N:	
	RoHS
40-01/X4C-4NQB	
QTY :	CAT:
	HUE:
LOT NO :	REF:
MADE IN TAIWAN	

PART NO: Everlight's Production Number

QTY: Packing Quantity

LOT NO: Lot Number

CAT: Ranks of Forward Voltage, Color Bin Grade and Total Flux

CPN: Customer's Production Number

P/N : Production Number

HUE: Reference

REF: Reference

MADE IN TAIWAN: Production Place



# Technical Data Sheet

## Warm White POWER LED

**40-01/X4C-4NOB**

### Notes

1. Above specification may be changed without notice. EVERLIGHT will reserve authority on material change for above specification.
2. When using this product, please observe the absolute maximum ratings and the instructions for using outlined in these specification sheets. EVERLIGHT assumes no responsibility for any damage resulting from use of the product which does not comply with the absolute maximum ratings and the instructions included in these specification sheets.
3. These specification sheets include materials protected under copyright of EVERLIGHT corporation. Please don't reproduce or cause anyone to reproduce them without EVERLIGHT's consent.
4. Below the zener reference voltage  $V_z$ , all the current flows through LED and as the voltage rises to  $V_z$ , the zener diode "breakdown." If the voltage tries to rise above  $V_z$  current flows through the zener branch to keep the voltage at exactly  $V_z$ .
5. When the LED is connected using serial circuit, if either piece of LED is no light up but current can't flow through causing others to light down. In new design, the LED is parallel with zener diode. if either piece of LED is no light up but current can flow through causing others to light.

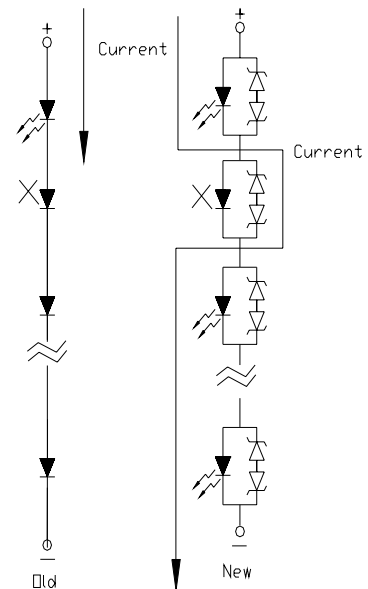

### 6. Soldering Condition



# Technical Data Sheet

## Warm White POWER LED

### 40-01/X4C-4NOB

Careful attention should be paid during soldering. When soldering, leave more than 3mm from solder joint to case, and soldering beyond the base of the tie bar is recommended.

Avoiding applying any stress to the lead frame while the LEDs are at high temperature particularly when soldering.

Recommended soldering conditions:

Hand Soldering		DIP Soldering	
Temp. at tip of iron	400°C Max. (30W Max.)	Preheat temp.	100°C Max. (60 sec Max.)
Soldering time	3 sec Max.	Bath temp.	265 Max.
Distance	3mm Min.(From solder joint to case)	Bath time.	5 sec Max.
		Distance	3mm Min.

**EVERLIGHT ELECTRONICS CO., LTD.**  
Office: No 25, Lane 76, Sec 3, Chung Yang Rd,  
Tucheng, Taipei 236, Taiwan, R.O.C.

Tel: 886-2-2267-2000, 2267-9936  
Fax: 886-2267-6244, 2267-6189, 2267-6306  
<http://www.everlight.com>