

1:10 Clock Fanout Buffer

Features

- Low-voltage operation
- Full-range support:
 - 3.3V
 - 2.5V
 - 1.8V
- Over voltage tolerant input hot swappable
- 1:10 fanout
- Drives either a 50-Ohm or 75-Ohm load
- Low-input capacitance
- Low-output skew
- Low-propagation delay
- Typical ($t_{pd} < 4$ ns)
- High-speed operation:
 - 200 MHz@1.8V
 - 650 MHz@2.5V/3.3V
- Industrial versions available
- Available packages include: SOIC, SSOP

Description

The Cypress series of network circuits are produced using advanced 0.35 micron CMOS technology, achieving the industries fastest logic and buffers.

The Cypress CY2CC910 fanout buffer features one input and ten outputs. Ideal for conversion from/to 3.3V/2.5V/1.8V

Designed for Data Communications clock management applications, the large fanout from a single input reduces loading on the input clock.

Cypress employs unique AVCMOS type outputs VOI™ (Variable Output Impedance) that dynamically adjust for variable impedance matching and eliminate the need for series damping resistors and reduce noise overall.

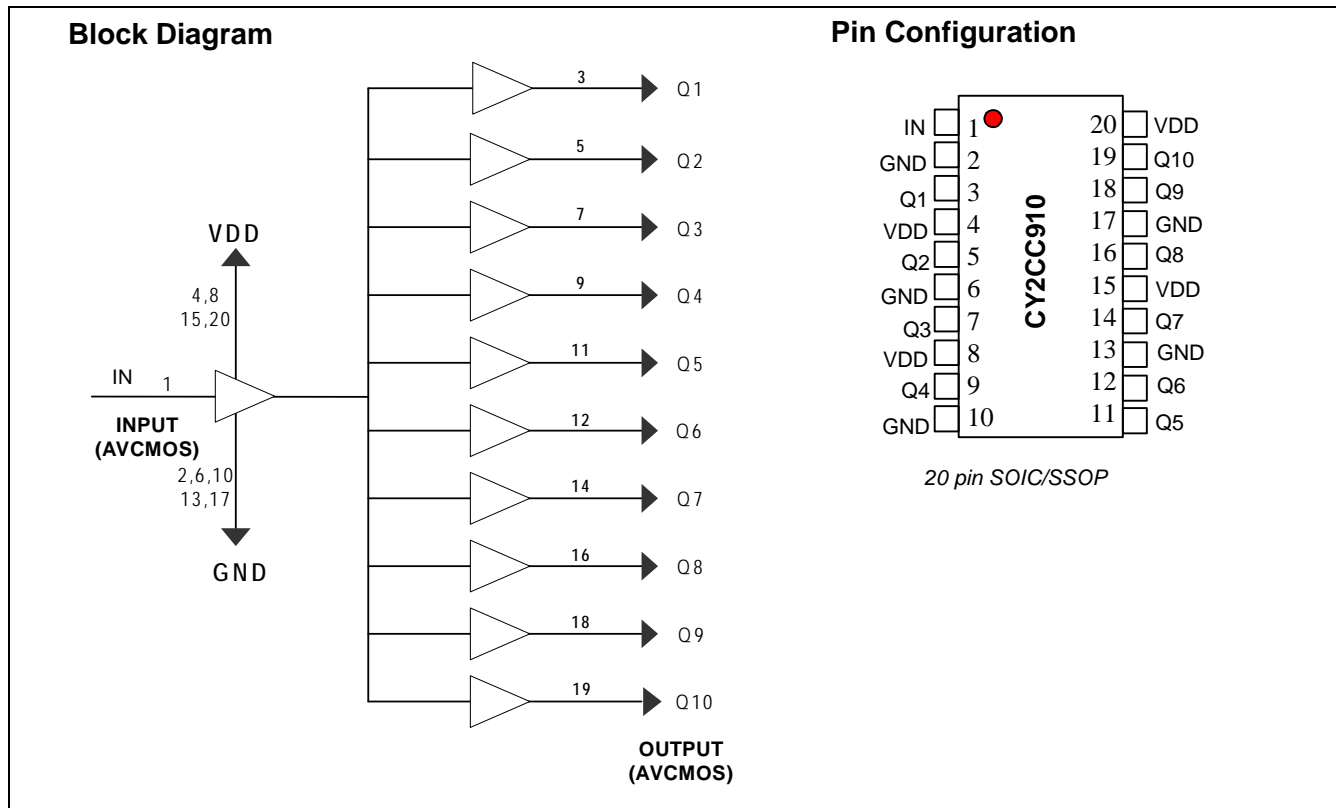

Pin Description

Pin Number	Pin Name	Description
1	IN	Input
2,6,10,13,17	GND	Ground
4,8,15,20	V _{DD}	Power Supply
3,5,7,9,11,12,14,16,18,19	Q1,Q2,Q3,Q4,Q5,Q6,Q7,Q8,Q9,Q10	Output

Maximum Ratings^[1]

Storage Temperature:	-65°C to +150°C	Supply Voltage to Ground Potential	
Ambient Temperature:.....	-40°C to +85°C	(Outputs only)	-0.5V to V _{DD} + 1V
Supply Voltage to Ground Potential		DC Output Voltage.....	-0.5V to V _{DD} + 1V
V _{CC}	-0.5V to 4.6V	Power Dissipation.....	0.75W
Input	-0.5V to 5.8V		

Variable Output Impedance Control (VOI™)

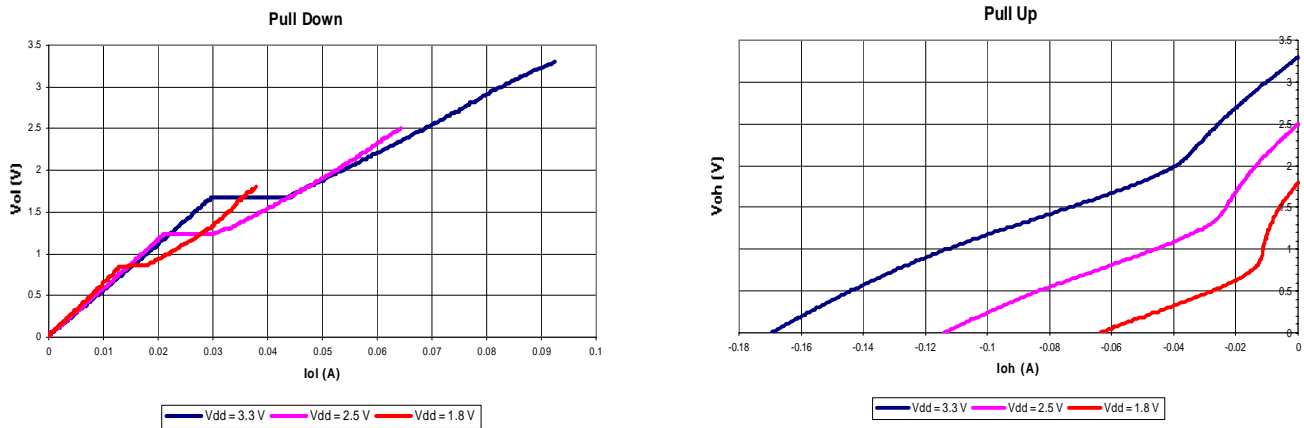

Figure 1. Output Voltage vs. Output Current (T_A = 25°C)

DC Electrical Characteristics @ 3.3V (see Figure 2)

Parameter	Description	Conditions	Min.	Typ.	Max.	Unit
V _{OH}	Output High Voltage	V _{DD} = Min., V _{IN} = V _{IH} or V _{IL}	I _{OH} = -12 mA	2.3	3.3	V
V _{OL}	Output Low Voltage	V _{DD} = Min., V _{IN} = V _{IH} or V _{IL}	I _{OL} = 12 mA		0.2	0.5 V
V _{IH}	Input High Voltage	Guaranteed Logic High Level		2	5.8	V
V _{IL}	Input Low Voltage	Guaranteed Logic Low Level			0.8	V
I _{IH}	Input High Current	V _{DD} = Max.	V _{IN} = 2.7V		1	μA
I _{IL}	Input Low Current	V _{DD} = Max.	V _{IN} = 0.5V		-1	μA
I _I	Input High Current	V _{DD} = Max., V _{IN} = V _{DD} (Max.)			20	μA
V _{IK}	Clamp Diode Voltage	V _{DD} = Min., I _{IN} = -18 mA		-0.7	-1.2	V
I _{OK}	Continuous Clamp Current	V _{DD} = Max., V _{OUT} = GND			-50	mA
O _{OFF}	Power-down Disable	V _{DD} = GND, V _{OUT} = < 4.5V			100	μA
V _H	Input Hysteresis			80		mV

Note:

1. Stresses greater than those listed under absolute maximum ratings may cause permanent damage to the device. This is intended to be a stress rating only and functional operation of the device at these or any other conditions above those indicated in the operation sections of this specification is not implied. Exposure to absolute maximum rating conditions for extended periods may affect reliability.

DC Electrical Characteristics @ 2.5V (see Figure 2)

Parameter	Description	Conditions	Min.	Typ.	Max.	Unit
V _{OH}	Output High Voltage	V _{DD} = Min., V _{IN} = V _{IH} or V _{IL}	I _{OH} = -7 mA	1.8		V
			I _{OH} = 12 mA	1.6		V
V _{OL}	Output Low Voltage	V _{DD} = Min., V _{IN} = V _{IH} or V _{IL}			0.65	V
V _{IH}	Input High Voltage	Guaranteed Logic High Level	1.6		5.0	V
V _{IL}	Input Low Voltage	Guaranteed Logic Low Level			0.8	V
I _{IH}	Input High Current	V _{DD} = Max.	V _{IN} = 2.4V		1	μA
I _{IL}	Input Low Current	V _{DD} = Max.	V _{IN} = 0.5V		-1	μA
I _I	Input High Current	V _{DD} = Max., V _{IN} = V _{DD} (Max.)			20	μA
V _{IK}	Clamp Diode Voltage	V _{DD} = Min., I _{IN} = -18 mA		-0.7	-1.2	V
I _{OK}	Continuous Clamp Current	V _{DD} = Max., V _{OUT} = GND			-50	mA
O _{OFF}	Power Down Disable	V _{DD} = GND, V _{OUT} = < 4.5V			100	μA
V _H	Input Hysteresis			80		mV

DC Electrical Characteristics @ 1.8V (see Figure 6)

Parameter	Description	Test Condition ^[2]	Min.	Max.	Unit
V _{DD}	Supply Voltage		1.71	1.89	V
V _{IH}	Input High Voltage		0.65V _{DD} [1.1]	4.3	V
V _{IL}	Input Low Voltage		-0.3	0.35 V _{DD} [0.6]	V
V _{OH}	Output High Voltage	I _{OH} = -2 mA	V _{DD} - 0.45[1.2]		V
V _{OL}	Output Low Voltage	I _{OH} = 2 mA		0.45	V

Capacitance

Parameter	Description	Test Conditions	Typ.	Max.	Unit
C _{IN}	Input Capacitance	V _{IN} = 0V	2.5		pF
C _{OUT}	Output Capacitance	V _{OUT} = 0V	6.5		pF

Power Supply Characteristics (see Figure 2)

Parameter	Description	Test Conditions	Min.	Typ	Max	Unit
ΔI _{CC}	Delta I _{CC} Quiescent Power Supply Current	(I _{DD} @ V _{DD} = Max and V _{IN} = V _{DD}) - (I _{DD} @ V _{DD} = Max and V _{IN} = V _{DD} - 0.6V)			50	μA
I _{CCD}	Dynamic Power Supply Current	V _{DD} = Max Input toggling 50% Duty Cycle, Outputs Open			0.63	mA/MHz
I _C	Total Power Supply Current	V _{DD} = Max Input toggling 50% Duty Cycle, Outputs Open fL = 40 MHz			25	mA

Note:

2. Test load conditions: 500-Ohm to ground with approximately 6-pF total loading and 200-MHz maximum frequency.

High Frequency Parametrics

Parameter	Description	Test Conditions	Min.	Typ.	Max.	Unit
D _J	Jitter, Deterministic	50% duty cycle t _W (50-50) The "point to point load circuit" Output Jitter – Input Jitter			20	ps
F _{max} 3.3V	Maximum frequency V _{DD} = 3.3V	50% duty cycle t _W (50-50) Standard Load Circuit.			160	MHz
		50% duty cycle t _W (50-50) The "point to point load circuit"			650	
F _{max} 2.5V	Maximum frequency V _{DD} = 2.5V	The "point-to-point load circuit" V _{IN} = 2.4V/0.0V V _{OUT} = 1.7V/0.7V			200	MHz
F _{max} 1.8V	Maximum frequency V _{DD} = 1.8V	The "6-pF load circuit" V _{IN} = 1.7/0.0V V _{OUT} = 1.2V/0.4V			200	MHz
F _{max(20)}	Maximum frequency V _{DD} = 3.3V	20% duty cycle t _W (20-80) The "point to point load circuit" V _{IN} = 3.0V/0.0V V _{OUT} = 2.3V/0.4V			250	MHz
t _W 3.3V	Minimum pulse V _{DD} = 3.3V	The "point-to-point load circuit" V _{IN} = 3.0V/0.0V F = 100 MHz V _{OUT} = 2.0V/0.8V	1			ns
t _W 2.5V	Minimum pulse V _{DD} = 2.5V	The "point-to-point load circuit" V _{IN} = 2.4V/0.0V F = 100 MHz V _{OUT} = 1.7V/0.7V	1			ns
t _W 1.8V	Minimum pulse V _{DD} = 1.8V	The "6-pF load circuit" V _{IN} = 1.7V/0.0V V _{OUT} = 1.2V/0.4V	1			ns

AC Switching Characteristics @ 3.3V V_{DD} = 3.3V ± 5%, Temperature = -40°C to +85°C

Parameter	Description	Min.	Typ.	Max.	Unit	
t _{PLH}	Propagation Delay – Low to High	See Figure 3	1.5	2.7	3.5	ns
t _{PHL}	Propagation Delay – High to Low		1.5	2.7	3.5	ns
t _R	Output Rise Time			0.8		V/ns
t _F	Output Fall Time			0.8		V/ns
t _{SK(0)}	Output Skew: Skew between outputs of the same package (in phase).	See Figure 10			0.2	ns
t _{SK(p)}	Pulse Skew: Skew between opposite transitions of the same output (t _{PHL} – t _{PLH}).	See Figure 9			0.2	ns
t _{SK(t)}	Package Skew: Skew between outputs of different packages at the same power supply voltage, temperature and package type.	See Figure 11			0.4	ns

AC Switching Characteristics @ 2.5V V_{DD} = 2.5V ± 5%, Temperature = -40°C to +85°C

Parameter	Description	Min.	Typ.	Max.	Unit	
t _{PLH}	Propagation Delay – Low to High	See Figure 3	1.5	2.7	3.5	ns
t _{PHL}	Propagation Delay – High to Low		1.5	2.7	3.5	ns
t _R	Output Rise Time			0.8		V/ns
t _F	Output Fall Time			0.8		V/ns
t _{SK(0)}	Output Skew: Skew between outputs of the same package (in phase).	See Figure 10			0.2	ns
t _{SK(p)}	Pulse Skew: Skew between opposite transitions of the same output (t _{PHL} – t _{PLH}).	See Figure 9			0.2	ns
t _{SK(t)}	Package Skew: Skew between outputs of different packages at the same power supply voltage, temperature and package type.	See Figure 11			0.4	ns

AC Switching Characteristics @ 1.8V $V_{DD} = 1.8V \pm 5\%$, Temperature = $-40^{\circ}C$ to $+85^{\circ}C$

Parameter	Description	Min.	Typ.	Max.	Unit	
t_{PLH}	Propagation Delay – Low to High	See Figure 7	1.5	2.7	3.5	ns
t_{PHL}	Propagation Delay – High to Low	See Figure 7	1.5	2.7	3.5	ns
t_R	Output Rise Time 20 – 80%		0.2	1.5	ns	
t_F	Output Fall Time 20 – 80%		0.2	1.5	ns	
$t_{SK(0)}$	Output Skew: Skew between outputs of the same package (in phase).	See Figure 10		0.2	ns	
$t_{SK(p)}$	Pulse Skew: Skew between opposite transitions of the same output ($t_{PHL} - t_{PLH}$).	See Figure 9		0.2	ns	
$t_{SK(t)}$	Package Skew: Skew between outputs of different packages at the same power supply voltage, temperature and package type.	See Figure 11		0.4	ns	

Parameter Measurement Information: V_{DD} @ 3.3V–2.5V

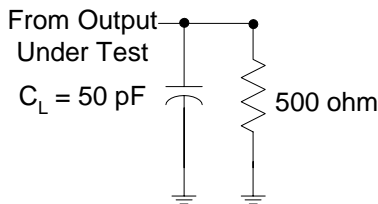

Figure 2. Load Circuit [3,4,5]

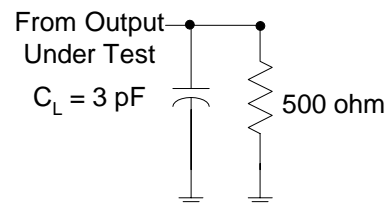

Figure 4. Point to Point Load Circuit [3,4,5]

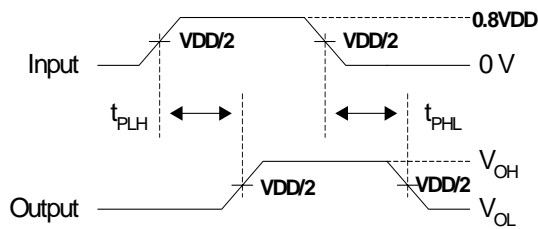

Figure 3. Voltage Waveforms Propagation Delay Times [6]

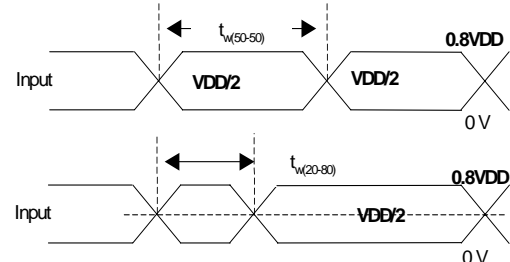

Figure 5. Voltage Waveforms–Pulse Duration [4]

Parameter Measurement Information: V_{DD} @ 1.8V

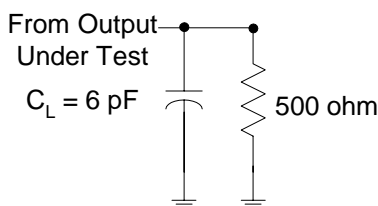

Figure 6. Load Circuit [3,4,5]

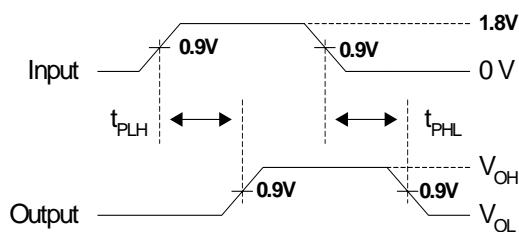

Figure 7. Voltage Waveforms Propagation Delay Times [6]

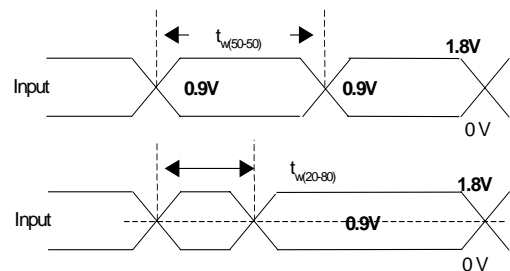
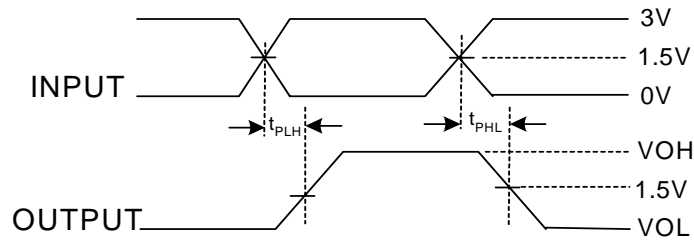

Figure 8. Voltage Waveforms–Pulse Duration [4]

Notes:

- C_L includes probe and jig capacitance.
- All input pulses are supplied by generators having the following characteristics: PRR < 100 MHz, $Z_0 = 50\Omega$, $t_R < 2.5$ ns, $t_F < 2.5$ ns.
- The outputs are measured one at a time with one transition per measurement.
- T_{PLH} and T_{PHL} are the same as t_{pd} .



$$tsk_{(p)} = |t_{PHL} - t_{PLH}|$$

Figure 9. Pulse Skew— $tsk_{(p)}$

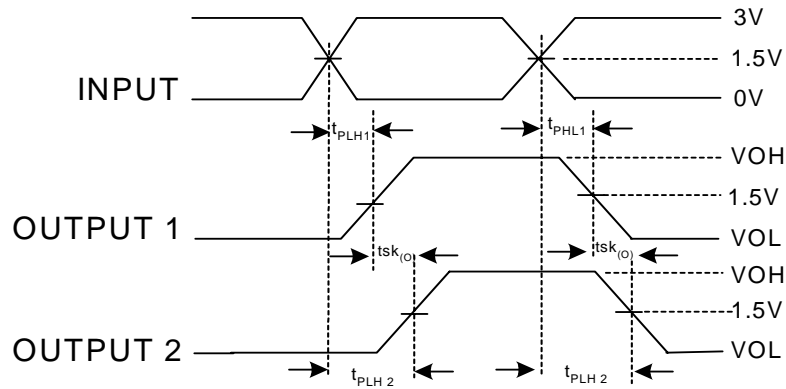

$$tsk_{(p)} = |t_{PLH2} - t_{PLH1}| \text{ or } |t_{PHL2} - t_{PHL1}|$$

Figure 10. Output Skew— $tsk_{(o)}$

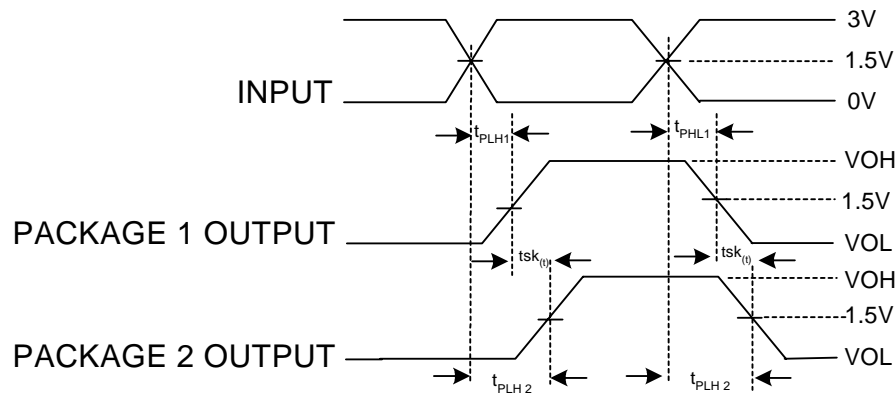

$$tsk_{(t)} = |t_{PLH2} - t_{PLH1}| \text{ or } |t_{PHL2} - t_{PHL1}|$$

Figure 11. Package Skew - $tsk_{(t)}$



Ordering Information

Part Number	Package Type	Product Flow
CY2CC910SI	20-pin SOIC	Industrial, -40° to 85°C
CY2CC910SIT	20-pin SOIC-Tape and Reel	Industrial, -40° to 85°C
CY2CC910SC	20-pin SOIC	Commercial, 0°C to 70°C
CY2CC910SCT	20-pin SOIC-Tape and Reel	Commercial, 0°C to 70°C
CY2CC910OI	20-pin SSOP	Industrial, -40° to 85°C
CY2CC910OIT	20-pin SSOP-Tape and Reel	Industrial, -40° to 85°C
CY2CC910OC	20-pin SSOP	Commercial, 0°C to 70°C
CY2CC910OCT	20-pin SSOP-Tape and Reel	Commercial, 0°C to 70°C
Lead-free		
CY2CC910OXI	20-pin SSOP	Industrial, -40° to 85°C
CY2CC910OXIT	20-pin SSOP-Tape and Reel	Industrial, -40° to 85°C
CY2CC910OXC	20-pin SSOP	Commercial, 0°C to 70°C
CY2CC910OXCT	20-pin SSOP-Tape and Reel	Commercial, 0°C to 70°C

Package Drawing and Dimensions

20-Lead (300-Mil) SOIC S5

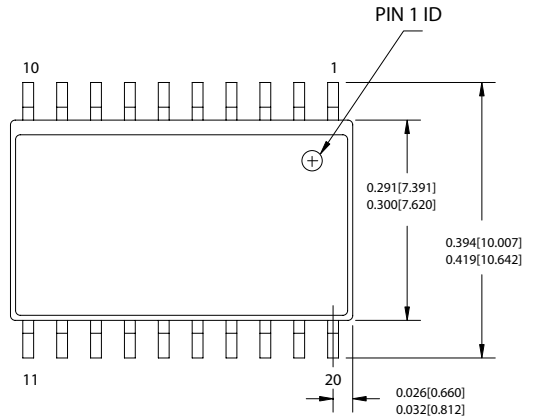

DIMENSIONS IN INCHES [MM] MIN. MAX.

REFERENCE JEDEC MO-119

PACKAGE WEIGHT 0.55 gms

PART #	
S20.3	STANDARD PKG.
SZ20.3	LEAD FREE PKG.

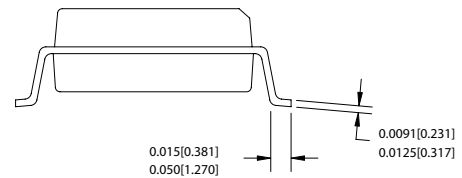
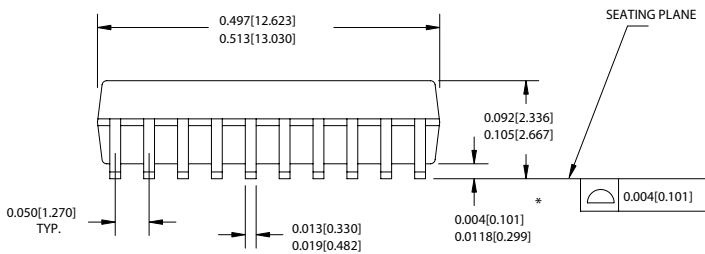

51-85024-*B

20-pin Shrink Small Outline Package O20

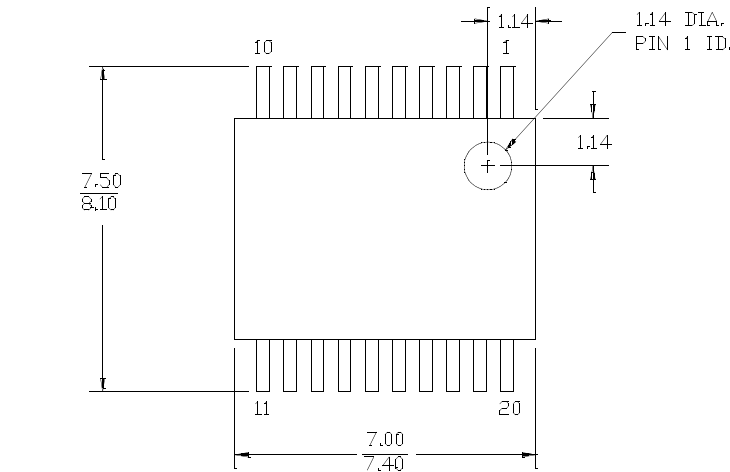

DIMENSIONS IN MILLIMETERS MIN. MAX.

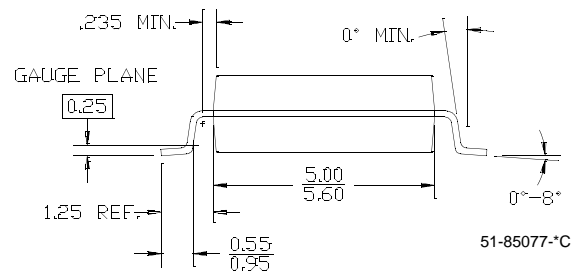
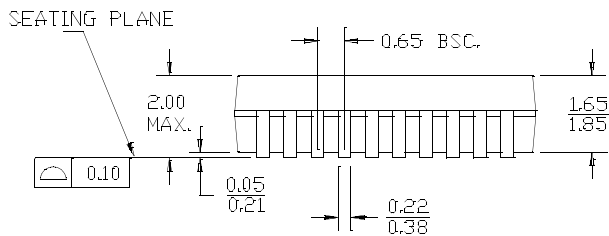

51-85077-*C

VOI is a trademark of Cypress Semiconductor. All product and company names mentioned in this document are the trademarks of their respective holders.



Document History Page

Document Title: CY2CC910 COMLINK™ SERIES 1:10 Clock Fanout Buffer Document #: 38-07348				
REV.	ECN NO.	Issue Date	Orig. of Change	Description of Change
**	114318	05/10/02	TSM	New Data Sheet
*A	119148	10/07/02	RGL	Added 5.8 as the Max. value for V_{IH} in the DC Electrical Characteristics @3.3V table. Changed the Max. value of V_{IH} from 5.8 to 5.0 in the DC Electrical Characteristics @2.5V table. Changed the value of V_{IH} from $V_{DD}+0.3$ [2.25] to 4.3 in the DC Electrical Characteristics @1.8V table.
*B	404287	See ECN	RGL	Added Lead-free devices for SSOP