

Features

- SD Memory Card Specification Version 1.01-compliant
- Up to 1 Gbyte of Formatted Data Storage
- Bus Mode
 - SD Protocol (1 to 4 Data Lines)
 - SPI Protocol
- Operating Voltage Range:
 - Basic Communication (CMD0, CMD15, CMD55 and ACMD41): 2.0V to 3.6V
 - Other Commands and Memory Access: 2.7V to 3.6V
- Variable Clock Rate: 0 to 25 MHz
- Read Access (using 4 Data Lines)
 - Sustained Multiple Block: 6.3 Mb/s
- Write Access (using 4 Data Lines)
 - Sustained Multiple Block: 3.0 Mb/s
- Maximum Data Rate with up to 10 Cards
- Aimed at Portable and Stationary Applications
- Communication Channel Protocol Attributes:
 - Six-wire communication channel (clock, command, 4 data lines)
 - Error-proof data transfer
 - Single or Multiple block oriented data transfer

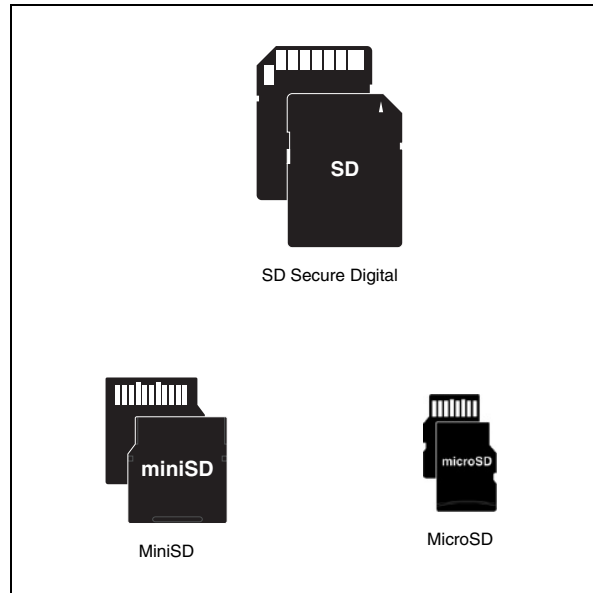

- Memory Field Error Correction
- Safe Card Removal during Read
- Write Protect Feature using Mechanical Switch
- Built-in Write Protection Features (Permanent and Temporary)
- SD, MiniSD and MicroSD Packages
 - ECOPACK® compliant
 - Halogen free
 - Antimony free

Table 1. Device summary

| Part Number | Package Form Factor | Operating Voltage Range |
|-------------|---------------------|-------------------------|
| SMS128AF | SD (full size) | 2.7V to 3.6V |
| SMS256AF | | |
| SMS512AF | | |
| SMS01GAF | | |
| SMS064BF | MiniSD | |
| SMS128BF | MicroSD | |
| SMS064FF | | |
| SMS128FF | | |
| SMS256FF | | |
| SMS512FF | | |

Contents

- 1 Description 8**
- 2 Memory array partitioning 11**
- 3 Secure digital memory card interface 13**
 - 3.1 Secure digital memory card bus topology 15
 - 3.2 SD bus protocol 16
 - 3.3 SD Memory Card Functional Description 19
 - 3.4 Operation Modes 19
 - 3.4.1 Card Identification Mode 20
 - 3.4.2 Data Transfer Mode 21
 - 3.5 Commands 23
 - 3.6 Responses 24
- 4 SD memory card hardware interface 26**
 - 4.1 SD memory card bus circuitry 26
 - 4.2 Power-Up 27
 - 4.3 Hot Insertion/Removal 28
 - 4.4 Power Protection 28
 - 4.5 Electrical Specifications 28
- 5 Card registers 31**
 - 5.1 OCR Register 31
 - 5.2 CID Register 32
 - 5.3 CSD Register 33
 - 5.4 RCA Register 34
 - 5.5 DSR Register (Optional) 34
 - 5.6 SCR Register 34
- 6 Timings 35**
 - 6.1 Command and Response 35
 - 6.1.1 Card Identification and Operating Conditions Timings 35
 - 6.1.2 Card Relative Address Timings 36

| | | |
|----------|---|-----------|
| 6.1.3 | Data Transfer Mode | 36 |
| 6.1.4 | Last Card Response, Next Host Command Timings | 36 |
| 6.1.5 | Last Host Command, Next Host Command Timings | 37 |
| 6.2 | Data Read | 37 |
| 6.2.1 | Single Block Read | 37 |
| 6.2.2 | Multiple Block Read | 37 |
| 6.3 | Data Write | 38 |
| 6.3.1 | Single Block Write | 38 |
| 6.3.2 | Multiple Block Write | 39 |
| 6.4 | STOP_TRANSMISSION Command | 39 |
| 6.4.1 | Erase, Set and Clear Write Protect Timings | 41 |
| 6.4.2 | Re-selecting a busy card | 41 |
| 6.5 | Timing Values | 41 |
| 7 | Serial peripheral interface (SPI) mode | 42 |
| 7.1 | SPI bus topology | 42 |
| 7.2 | SPI Bus Protocol | 43 |
| 7.2.1 | Mode Selection | 43 |
| 7.2.2 | Bus Transfer Protection | 44 |
| 7.2.3 | Data Read | 44 |
| 7.2.4 | Data Write | 45 |
| 7.2.5 | Erase & Write Protect Management | 45 |
| 7.2.6 | Read CID/CSD Registers | 46 |
| 7.2.7 | Reset Sequence | 46 |
| 7.2.8 | Memory Array Partitioning. | 46 |
| 7.2.9 | Card Lock/Unlock Commands. | 46 |
| 7.2.10 | Application Specific Commands. | 46 |
| 7.3 | SPI Mode Commands | 46 |
| 7.4 | Responses | 47 |
| 7.4.1 | R1 Format | 47 |
| 7.4.2 | R1b Format | 48 |
| 7.4.3 | R2 Format | 48 |
| 7.4.4 | R3 Format | 48 |
| 7.5 | Clearing Status Bits | 48 |
| 7.6 | SPI Bus Timings | 48 |
| 7.6.1 | Data Read Timings | 50 |

7.6.2 Data Write Timings 51

8 Package mechanical data 53

9 Part numbering 58

Appendix A Power supply decoupling 59

10 Revision history 60

List of tables

| | | |
|-----------|---|----|
| Table 1. | Device summary | 1 |
| Table 2. | System performance | 8 |
| Table 3. | Power consumption | 9 |
| Table 4. | Environmental specifications | 9 |
| Table 5. | Physical dimensions | 9 |
| Table 6. | System reliability and maintenance | 10 |
| Table 7. | Memory array structures | 11 |
| Table 8. | Full-size SD Memory Card pin assignment | 13 |
| Table 9. | MicroSD Contact Pad Assignment | 14 |
| Table 10. | Card States vs. Operation Modes | 19 |
| Table 11. | SD Card Command Format | 24 |
| Table 12. | Response R1 | 25 |
| Table 13. | Response R2 | 25 |
| Table 14. | Response R3 | 25 |
| Table 15. | Response R6 | 25 |
| Table 16. | Bus Operating Conditions | 29 |
| Table 17. | Bus Signal Condition - I/O Signal Voltages | 29 |
| Table 18. | Bus Timings | 30 |
| Table 19. | SD Memory Card Registers | 31 |
| Table 20. | OCR Register Definition | 31 |
| Table 21. | CID Fields | 32 |
| Table 22. | CSD Fields Compatible with CSD Structure V1 / MM Card Specification V2.11 | 33 |
| Table 23. | SCR Fields | 34 |
| Table 24. | Timing Diagram Symbols | 35 |
| Table 25. | Timing Values | 41 |
| Table 26. | Command Format | 47 |
| Table 27. | Command Classes in SPI Mode | 47 |
| Table 28. | SPI Timing Symbols | 48 |
| Table 29. | SPI Timing Values | 49 |
| Table 30. | Full-Size Secure Digital Memory Card Mechanical Data | 53 |
| Table 31. | MiniSD package mechanical data | 54 |
| Table 32. | MicroSD package mechanical data | 56 |
| Table 33. | Ordering Information Scheme | 58 |
| Table 34. | Document Revision History | 60 |

List of figures

| | | |
|------------|---|----------------|
| Figure 1. | Write Protection hierarchy | 12 |
| Figure 2. | Full size Secure Digital Memory Card form factor | 13 |
| Figure 3. | MicroSD pin assignment. | 14 |
| Figure 4. | Secure Digital Memory Card system bus topology | 16 |
| Figure 5. | "No Response" and "No Data" operations | 17 |
| Figure 6. | (Multiple) Block Read operation | 17 |
| Figure 7. | (Multiple) Block Write operation | 18 |
| Figure 8. | Command Token format | 18 |
| Figure 9. | response token format | 18 |
| Figure 10. | Data Packet format | 19 |
| Figure 11. | SD Memory Card State Diagram (Card Identification Mode) | 21 |
| Figure 12. | SD Memory Card State Diagram (Data Transfer Mode) | 23 |
| Figure 13. | Full Size SD Memory Card Circuitry | 26 |
| Figure 14. | Power-Up Diagram | 27 |
| Figure 15. | Bus Signal levels | 29 |
| Figure 16. | Data Input/Output Timings Referenced to Clock | 30 |
| Figure 17. | Identification Sequence | 36 |
| Figure 18. | SEND_RELATIVE_ADDRESS Command | 36 |
| Figure 19. | Response (Data Transfer Mode) | 36 |
| Figure 20. | Response End To Next CMD Start (Data Transfer Mode) | 36 |
| Figure 21. | Command Sequence (All Modes) | 37 |
| Figure 22. | Single Block Read Command | 37 |
| Figure 23. | Multiple Block Read Command | 38 |
| Figure 24. | STOP_TRANSMISSION Command (CMD12, Data Transfer Mode) | 38 |
| Figure 25. | Block Write Command | 39 |
| Figure 26. | Multiple Block Write Command | 39 |
| Figure 27. | STOP_TRANSMISSION During Data Transfer From The Host | 40 |
| Figure 28. | STOP_TRANSMISSION During CRC Status Transfer From Card | 40 |
| Figure 29. | STOP_TRANSMISSION Received After Last Data Block with Card Busy | Programming 40 |
| Figure 30. | STOP_TRANSMISSION Received After Last Data Block with Card Idle | 41 |
| Figure 31. | SD Memory Card System SPI Mode Bus Topology | 43 |
| Figure 32. | Read Operation Mechanism | 44 |
| Figure 33. | Multiple Block Read Operation | 44 |
| Figure 34. | Read Data Error | 45 |
| Figure 35. | Write Operation | 45 |
| Figure 36. | Erase & Write Protect Operations | 45 |
| Figure 37. | Host Command to Card Response - Card is Ready | 49 |
| Figure 38. | Host Command to Card Response - Card is Busy | 49 |
| Figure 39. | Card Response to Host Command | 50 |
| Figure 40. | Single Block Read Operation | 50 |
| Figure 41. | STOP_TRANSMISSION between Blocks During Multiple Block Read | 50 |
| Figure 42. | STOP_TRANSMISSION within a Block During Multiple Block Read | 51 |
| Figure 43. | CSD Register Read Operation | 51 |
| Figure 44. | Single Block Write Operation | 51 |
| Figure 45. | Multiple Block Write Operation | 52 |
| Figure 46. | Full-Size Secure Digital Memory Card Dimensions | 53 |
| Figure 47. | mini Secure Digital Card Dimensions | 54 |
| Figure 48. | MicroSD card mechanical dimensions | 56 |

Figure 49. Power supply decoupling 59

1 Description

The Secure Digital Memory Card (SD Memory Card) is a Flash-Based Memory Card. It is specifically designed to meet the security, capacity, performance and environmental requirements of the latest-generation audio and video consumer electronic devices, that is mobile phones, digital cameras, digital recorders, PDAs, organizers, electronic toys, etc.

The Secure Digital Memory Card is a high-mobility, high-performance, low-cost and low-power consumption device that features high data throughput at the memory card interface. It includes a copyright protection mechanism that complies with the security of the SDMI (Secure Digital Music Initiative) standard. The Secure Digital Memory Card security system uses mutual authentication and a "cipher algorithm" that protects the card from illegal use. Unsecured access to the user's personal content is also available.

The Secure Digital Memory Cards have an advanced communication interface designed to operate in a low voltage range. The full-size Secure Digital Memory Card has a 9-pin interface whereas the Mini Secure Digital Memory Card has a 11-pin interface but can be fitted with a 9-pin adapter. Only the 9-pin interface is described in this document. The MicroSD Memory Card has an 8-pin interface, and can also be fitted with a 9-pin adapter.

[Table 2](#), [Table 3](#), [Table 4](#), [Table 5](#), and [Table 6](#) give an overview of the Secure Digital Memory Card features.

In order to meet environmental requirements, the devices are offered in ECOPACK® packages. ECOPACK packages are Lead-free. The category of second Level Interconnect is marked on the package and on the inner box label, in compliance with JEDEC Standard JESD97. The maximum ratings related to soldering conditions are also marked on the inner box label.

The SD, MiniSD and MicroSD packages are also Halogen free and Antimony free.

Related documentation

- Secure Digital Memory Card Specifications: Part 1 Physical Layer Specification, Version 1.01
- MiniSd Memory Card Specifications: Addendum to SD Memory Card Specifications Part 1 Physical layer Specification, Version 1.02
- MicroSD Memory Card Specifications: Addendum to SD Memory Card Specifications Part 1, Physical Layer Specification, Version 1.00

Table 2. System performance

| System performance | Max. | Typ. | Unit |
|---|------|-----------|----------|
| Sleep to Ready | 30 | | µs |
| Sustained Multiple Block Read ⁽¹⁾ | | 6.3 (43X) | MBytes/s |
| Burst Single Block Read ⁽¹⁾ | | 1.8 (12X) | MBytes/s |
| Sustained Multiple Block Write ⁽¹⁾ | | 3.0 (20X) | MBytes/s |
| Burst Single Block Write ⁽¹⁾ | | 0.8 (5X) | MBytes/s |
| Power-up to Ready | 150 | | ms |

1. 43X, 20X, 12X and 5X Speed grade markings where 1X = 150 KBytes/s.

Table 3. Power consumption⁽¹⁾

| Mode | Max. Current Consumption |
|---------|--------------------------|
| Standby | 200 μ A |
| Read | 30 mA |
| Write | 30 mA |

1. $T_A = 25^\circ\text{C}$, $V_{DD} = 3.6\text{V}$.

Table 4. Environmental specifications⁽¹⁾

| Environmental specifications | | Operating | Non-Operating |
|------------------------------|--------------|---|--|
| Temperature | | -25°C to 85°C | -40°C to 85°C |
| Humidity (non- condensing) | | NA | $85^\circ\text{C} - 85\%\text{RH}$ |
| ESD Protection | Contact Pads | NA | $\pm 4\text{kV}$, Human body model according to ANSI EOS/ESD-S5.1-1998 |
| | Other | | $\pm 8\text{kV}$ (coupling plane discharge) $\pm 15\text{kV}$ (air discharge) Human body model per IEC61000-4-2 |
| Salt Water Spray | | NA | $T_A = 35^\circ\text{C}$ 3% NaCl (MIL Std Method 1009) |
| Vibration (peak-to-peak) | | NA | 15 Gmax |
| Shock | | NA | 1,000G |
| Drop | | NA | 2000G |
| Bending | | | 20N (middle of the card) |
| | | | 20N (border of the card) |
| UV light exposure | | | 254nm, 15Ws/cm ² |

1. NA = Not Applicable; RH = Relative Humidity; ESD = ElectroStatic Discharge

Table 5. Physical dimensions

| Parameter | SD | MiniSD | MicroSD | Unit |
|----------------|-----------|-----------|----------------------------------|------|
| Width | 24 | 20 | 11 | mm |
| Height | 32 | 21.5 | 15 | mm |
| Thickness | 2.1 | 1.4 | Inter Connect Area 0.7 ± 0.1 | mm |
| | | | Max. Card Thickness 0.95 | |
| | | | Max. Pull Area 1.0 ± 0.1 | |
| Weight | Approx. 2 | Approx. 1 | <1 | g |
| Number of Pins | 9 | 11 | 8 | N/A |

Table 6. System reliability and maintenance

| MTBF ⁽¹⁾ | >1,000,000hrs |
|------------------------|--|
| Preventive Maintenance | None |
| Data Reliability | 1 non-recoverable bit in 10 ¹⁴ bit read |
| Endurance | >2,000,000 Program/Erase Cycles |

1. MTBF = Mean Time Between Failures.

2 Memory array partitioning

The basic unit of data transfer to/from the SD Memory Card is the Byte. The memory array is divided into several structures as described below and summarized in [Table 17](#).

Block

The Block is the unit structure related to block-oriented read and write commands. Its size is the number of Bytes that are transferred when a block-oriented read or write command is sent by the host. The SD Memory Card Block size is either programmable or fixed. The information about allowed block sizes and programmability is stored in the CSD Register. The details of the Memory Array Structure and the number of addressable Blocks are shown in [Table 17](#).

Sector

The sector is the unit structure related to the erase commands. Its size is the number of blocks that are erased at any one time. The sector size is fixed for each device. The information about the sector size (in blocks) is stored in the CSD register.

Write Protect Group (WP-Group)

The WP-Group is the smallest structure that may be individually protected. Its size is the number of Sectors that are Write Protected with one bit. The information about the Write Protect Group size is stored in the CSD Register.

Table 7. Memory array structures

| Type of Structure | Number of structures in device | | | | | | |
|-------------------|--------------------------------|------------------|------------------|-------------------|-------------------|-------------------|-----------------|
| | Unit | 32 MByte Devices | 64 MByte Devices | 128 MByte Devices | 256 MByte Devices | 512 MByte Devices | 1 GByte Devices |
| Blocks | 512 Bytes | 59776 | 122624 | 248320 | 499712 | 1002496 | 1999872 |
| Sector | Block | 128 | 128 | 128 | 128 | 128 | 128 |
| WP-Groups | Sector | 1 | 2 | 4 | 8 | 16 | 32 |

Figure 1. Write Protection hierarchy

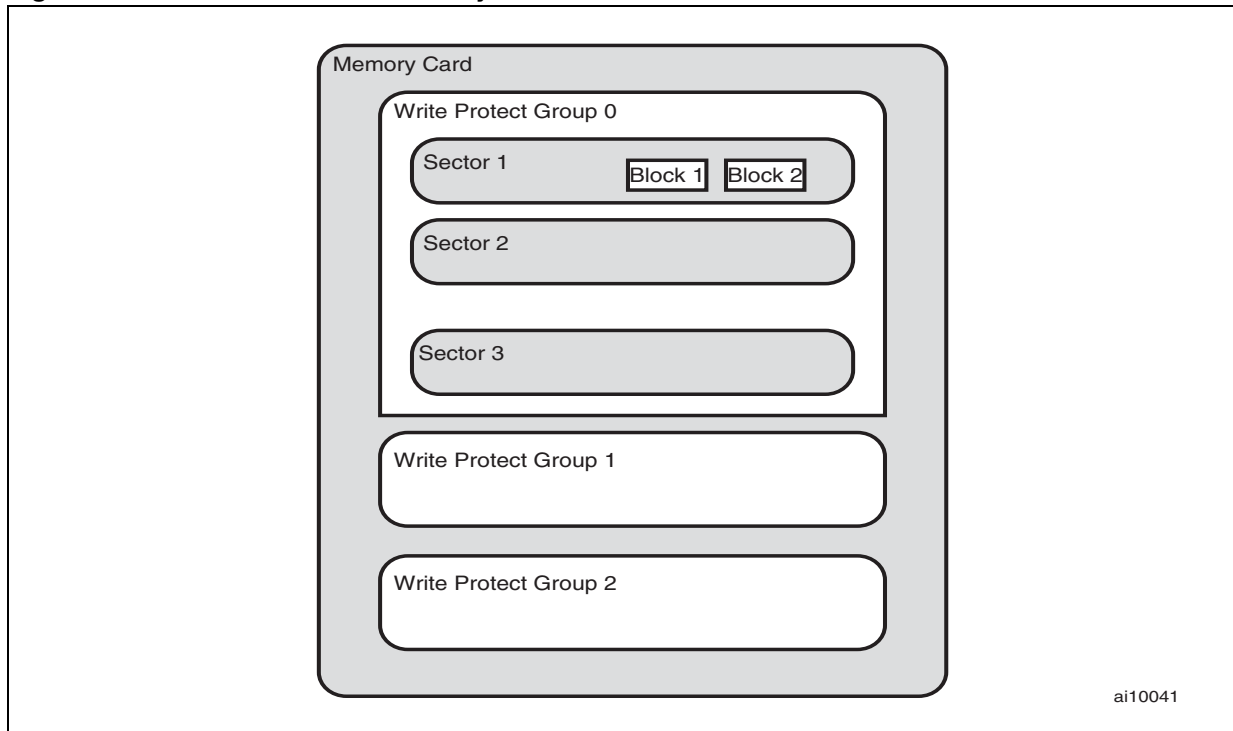

ai10041

3 Secure digital memory card interface

This section applies to the full-size SD Memory Card only, or to the MiniSD and MicroSD card when used with an adapter.

Details on the 11-pin communication interface of the MiniSD card used without an adapter are still to be announced. [Figure 3: MicroSD pin assignment](#) shows the MicroSD pinout.

The Secure Digital Memory Card has an advanced 9-pin communication interface (Clock, Command, 4 Data pins and 3 Power Supply pins) designed to operate in a low voltage range. The Secure Digital Card has its nine pins exposed on one side (see [Figure 2](#)). The signal/pin assignments are listed in [Table 8](#). The pin types are Power Supply, Input, Output and Push-Pull. The signals include six communication lines CMD, DAT0, DAT1, DAT2, DAT3, CLK and three supply lines V_{DD} , V_{SS1} and V_{SS2} .

Figure 2. Full size Secure Digital Memory Card form factor

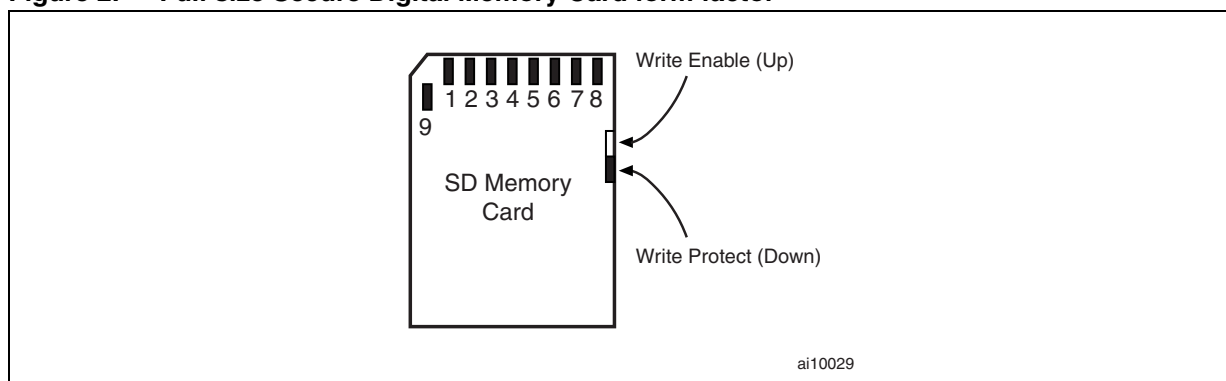
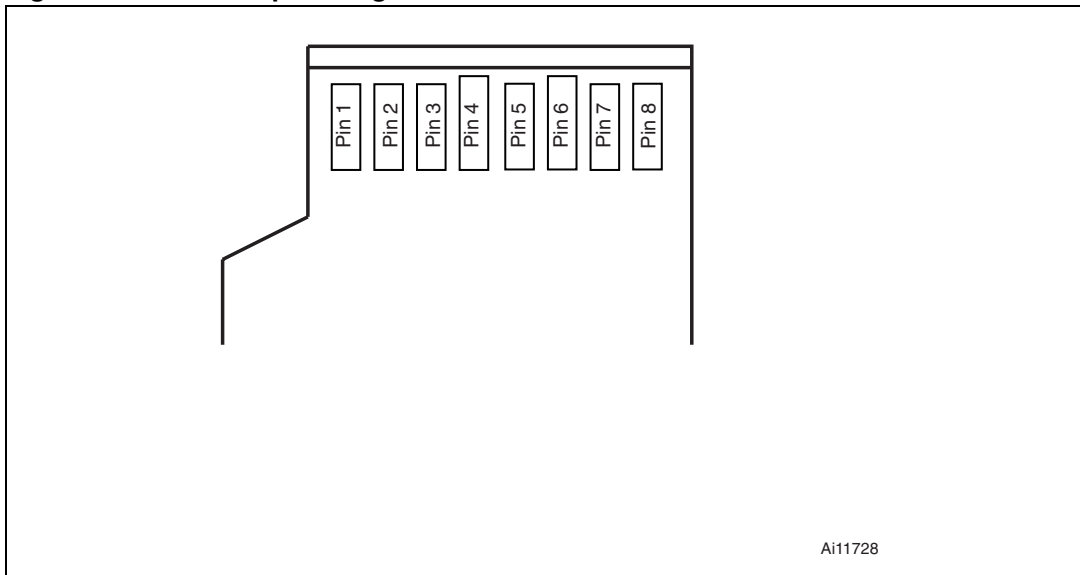

Table 8. Full-size SD Memory Card pin assignment

| Pin # | SD mode | | | SPI mode | | |
|-------|------------------------|-----------------------|---------------------------------|-----------|------|--------------------------|
| | Name | Type ⁽¹⁾ | Description | Name | Type | Description |
| 1 | CD/DAT3 ⁽²⁾ | I/O/PP ⁽³⁾ | Card Detect / Data Line [Bit 3] | CS | I | Chip Select (active Low) |
| 2 | CMD | PP | Command/Response | DI | I | Data In |
| 3 | V_{SS1} | S | Supply voltage ground | V_{SS} | S | Supply voltage ground |
| 4 | V_{DD} | S | Supply voltage | V_{DD} | S | Supply voltage |
| 5 | CLK | I | Clock | SCLK | I | Clock |
| 6 | V_{SS2} | S | Supply voltage ground | V_{SS2} | S | Supply voltage ground |
| 7 | DAT0 | I/O/PP | Data Line [Bit 0] | DO | O/PP | Data Out |
| 8 | DAT1 ⁽²⁾ | I/O/PP | Data Line [Bit 1] | Reserved | | |
| 9 | DAT2 ⁽²⁾ | I/O/PP | Data Line [Bit 2] | Reserved | | |

1. S: power supply; I: input; O: output using push-pull drivers; PP: I/O using push-pull drivers.
2. The extended DAT lines (DAT1-DAT3) are input on power-up. They start to operate as DAT lines after SET_BUS_WIDTH command.
3. After power-up this line is input with 50kΩ pull-up (can be used for card detection or SPI mode selection). The pull-up should be disconnected by the user, during regular data transfer, with SET_CLR_CARD_DETECT (ACMD42) command.

Figure 3. MicroSD pin assignment



Ai11728

Table 9. MicroSD Contact Pad Assignment

| Pin | SD Mode | | | SPI Mode | | |
|-----|------------------------|-----------------------|---------------------------------|-----------------|------|------------------------|
| | Name | Type ⁽¹⁾ | Description | Name | Type | Description |
| 1 | DAT2 | I/O/PP | Data Line [Bit 2] | RSV | | Reserved |
| 2 | CD/DAT3 ⁽²⁾ | I/O/PP ⁽³⁾ | Card Detect / Data Line [Bit 3] | CS | I | Chip Select (neg true) |
| 3 | CMD | PP | Command/Response | DI | I | Data In |
| 4 | V _{DD} | S | Supply voltage | V _{DD} | S | Supply voltage |
| 5 | CLK | I | Clock | SCLK | I | Clock |
| 6 | V _{SS} | S | Supply voltage ground | V _{SS} | S | Supply voltage ground |
| 7 | DAT0 | I/O/PP | Data Line [Bit 0] | DO | O/PP | Data Out |
| 8 | DAT1 | | | RSV | | Reserved |

1. S: power supply; I: input; O: output using push-pull drivers; PP: I/O using push-pull drivers.
2. The extended DAT lines (DAT1-DAT3) are input on power up. They start to operate as DAT lines after SET_BUS_WIDTH command. The Host shall keep its own DAT1-DAT3 lines in input mode, as well, while they are not used. It is defined so, in order to keep compatibility to MultiMediaCards.
3. After power up this line is input with 50KOhm pull-up (can be used for card detection or SPI mode selection). The pull-up should be disconnected by the user, during regular data transfer, with SET_CLR_CARD_DETECT (ACMD42) command.

3.1 Secure digital memory card bus topology

The Secure Digital Memory Card system defines two alternative communications protocols: SD and SPI that correspond to two operating modes.

Either mode can be selected in the application, mode selection is transparent to the host. The host automatically detects the operating mode of the card by issuing the Reset command (refer to [Section 7.2.1: Mode Selection](#)) and will expect all further communications to use the same mode. Therefore, applications that use only one communication mode do not have to be aware of the other.

The SD bus includes the following signals:

- CLK: Host to card clock signal
- CMD: Bi-directional Command/Response signal
- DAT0 - DAT3: 4 Bi-directional data signals.
- V_{DD} , V_{SS1} , V_{SS2} : Power and ground signals.

The SD Memory Card bus has a synchronous star topology (refer to [Figure 4: Secure Digital Memory Card system bus topology](#)) with a single master (the application) and multiple slaves (the cards). The Clock, power and ground signals are common to all cards. The command (CMD) and data (DAT0 - DAT3) signals are dedicated to the cards, they provide continuous point-to-point connection to all the cards.

During the initialization process, commands are sent to each card individually, allowing the application to detect the cards and assign logical addresses to the physical slots. Data is always sent (received) to (from) each card individually. However, in order to simplify the handling of the card stack, after the initialization process, all commands may be sent concurrently to all cards. Addressing information is provided in the command packet.

The SD bus allows dynamic configuration of the number of data lines. After power-up the SD Memory Card defaults to using only DAT0 for data transfer. After initialization the host can change the bus width (number of active data lines). This feature is an easy trade off between hardware cost and system performance.

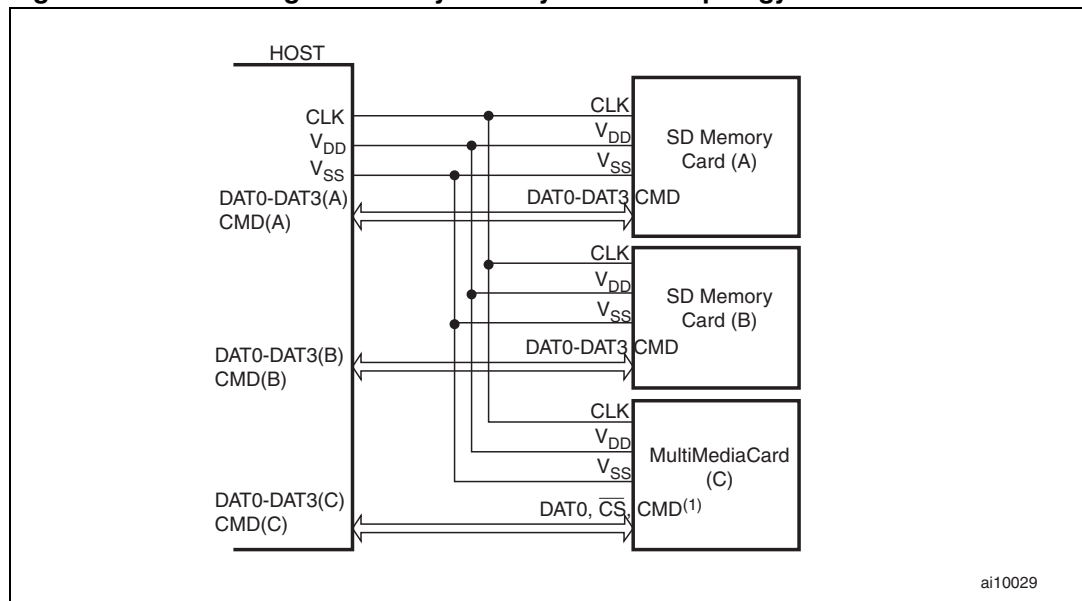
Figure 4. Secure Digital Memory Card system bus topology

1. DAT1 and DAT2 not connected.

3.2 SD bus protocol

Communication over the SD bus is based on command and data bit streams which are initiated by a start bit and terminated by a stop bit.

- Command:** a command is a token which starts an operation. A command is sent from the host either to a single card (addressed command) or to all connected cards (broadcast command). Commands are transferred serially on the CMD line. See [Figure 5: "No Response" and "No Data" operations](#). The Command token format is shown in [Figure 8](#)
- Response:** a response is a token which is sent from an addressed card, or (simultaneously) from all connected cards, to the host, as an answer to a previously received command. Responses are transferred serially on the CMD line. A response is illustrated in [Figure 5: "No Response" and "No Data" operations](#). The Response token format is shown in [Figure 9](#)
- Data:** data can be transferred from the card to the host or from the host to the card. Data is transferred via the data lines. See [Figure 6: \(Multiple\) Block Read operation](#) for an illustration. The Data Packet format is shown in [Figure 10](#)

Card addressing is implemented using a session address assigned to the card during the initialization phase (See SD Memory Card Specification, Chapter 4). The basic transaction on the SD bus is the command/response transaction. In this type of bus transactions, the information is directly transferred within the command or response structure. In addition, some operations have a data token. Data transfers to/from the SD Memory Card are done in blocks. Data blocks are always followed by CRC bits.

Single and Multiple Block operations are supported. Note that the Multiple Block operation mode improves the speed of write operations. A Multiple Block transmission is terminated by issuing a STOP_TRANSMISSION command on the CMD line (See [Figure 6](#) and [Figure 7](#)).

Data transfer can be configured by the host to use single or multiple data lines (provided that the card supports this feature).

A busy signal on DAT0 is used to indicate that a Block Write operation is ongoing (see [Figure 7](#)). The same busy signaling is used regardless of the number of data lines used to transfer the data.

Response tokens (see [Figure 9](#)) have four coding schemes depending on their content. The token length is either 48 or 136 bits (See SD Memory Card Specification, Chapter 4.5 for detailed definitions of the commands and responses). The CRC protection algorithm for data block is a 16-bit CCITT polynomial (see SD Memory Card Specification, chapter 4.5).

On the CMD line, the MSB bit is transmitted first and the LSB bit last. When the wide bus option is used, the data is transferred 4 bits at a time (refer to [Figure 10](#)). Start bits, End bits and CRC bits, are transmitted on all the DAT lines used. CRC bits are calculated and checked for every DAT line individually. The CRC status response and Busy indication are sent by the card to the host on DAT0 only (DAT1-DAT3 are Don't Care).

Figure 5. "No Response" and "No Data" operations

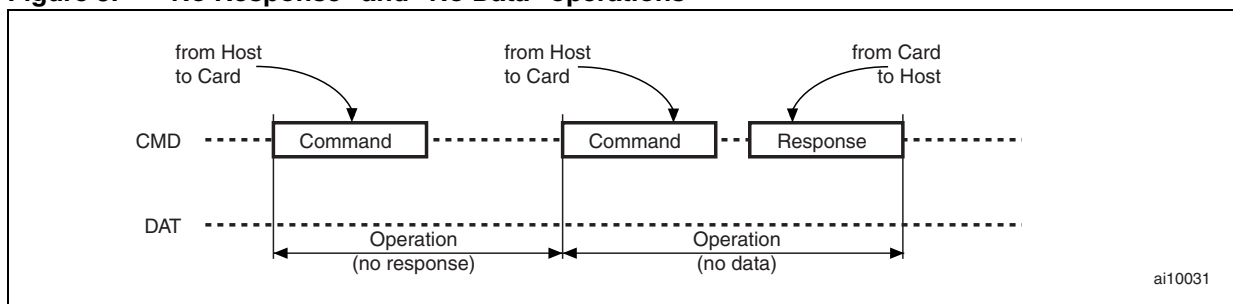

Figure 6. (Multiple) Block Read operation

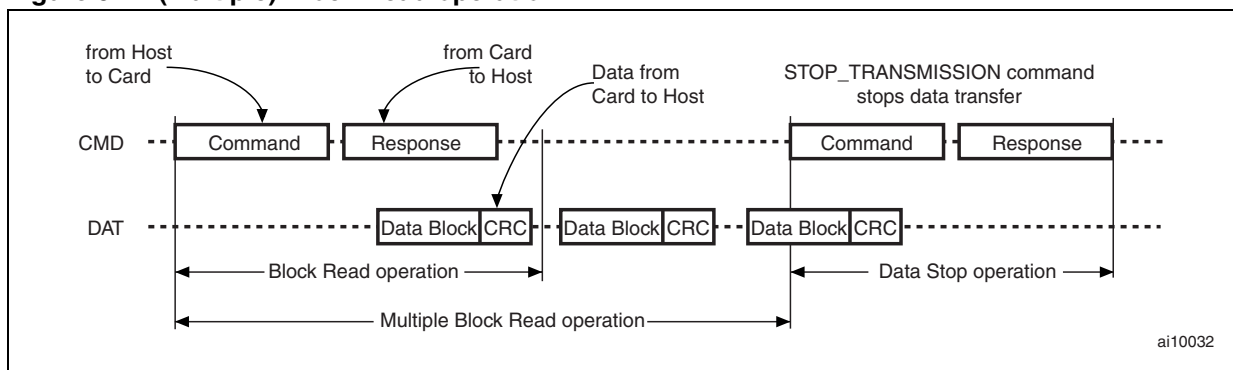

Figure 7. (Multiple) Block Write operation

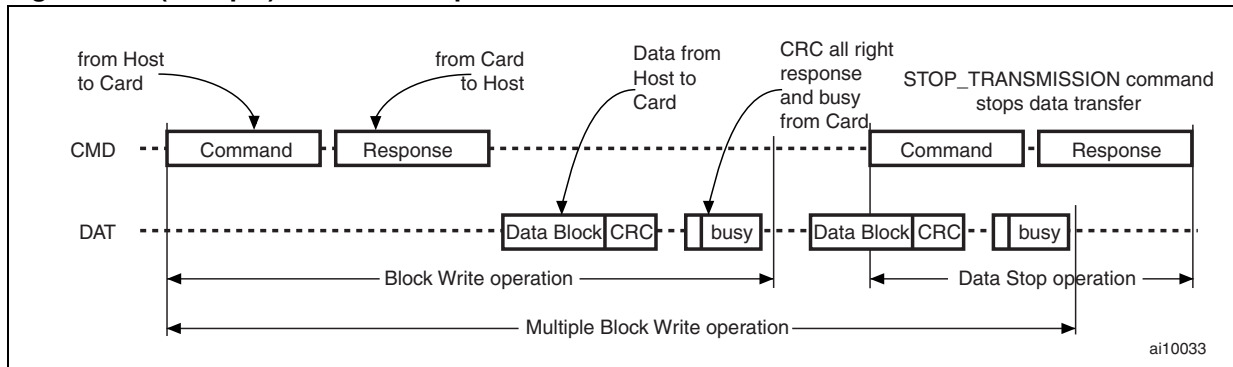

Figure 8. Command Token format

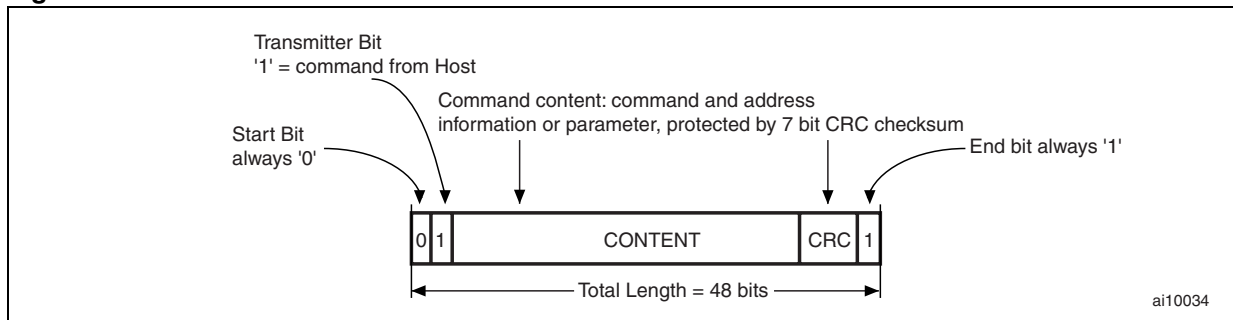

Figure 9. response token format

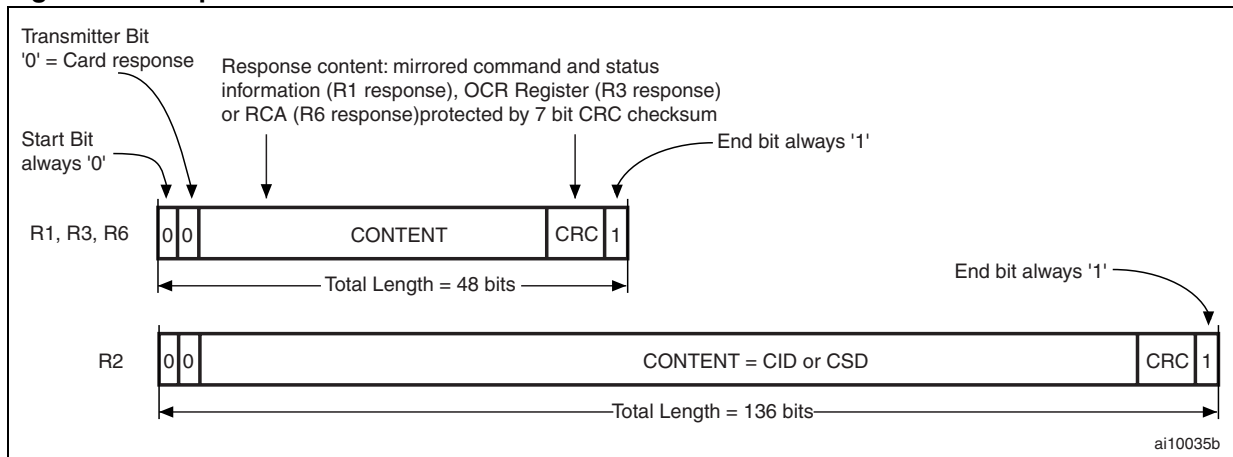
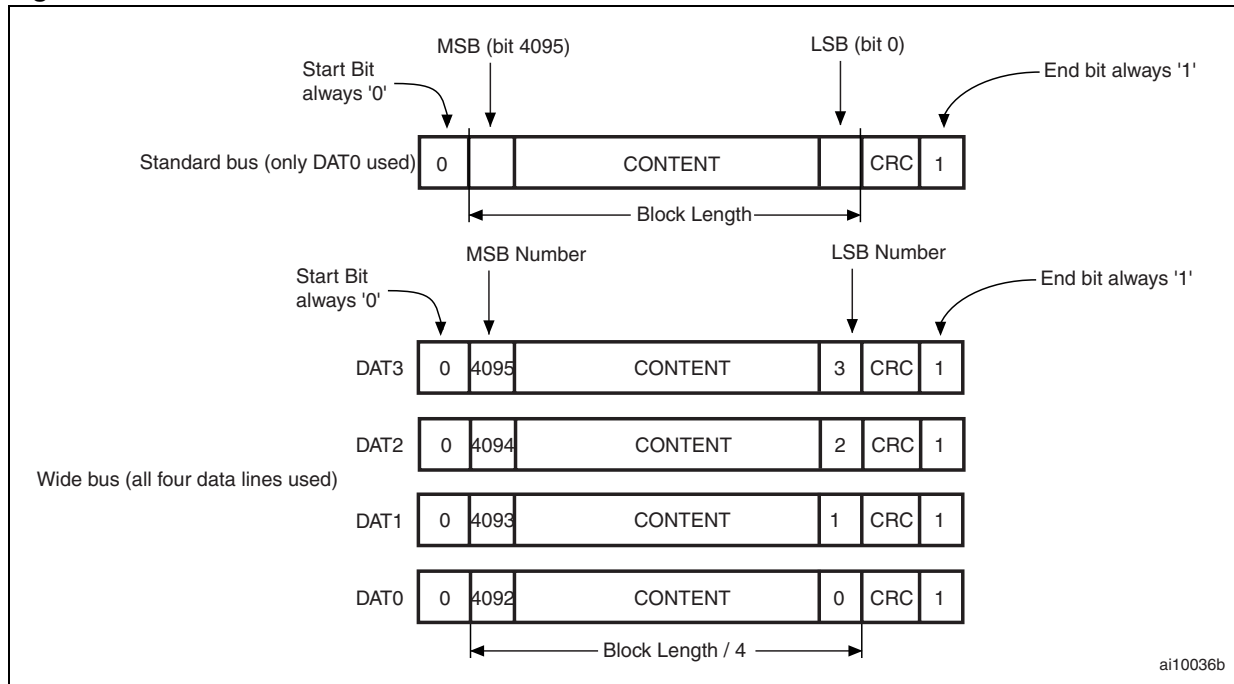

Figure 10. Data Packet format



3.3 SD Memory Card Functional Description

All communications between the host and the cards are controlled by the host (master).

The host sends commands of two types:

- **Broadcast commands** which are intended for all cards. Some of these commands require a response.
- **Addressed (point-to-point) commands** that are sent to the addressed card and are followed by a response from the card.

3.4 Operation Modes

Figure 11 and Figure 12 show an overview of the command flow for the Card Identification mode and the Data Transfer mode, respectively.

Table 10 shows the relationship between operation modes and card states. Each state in the SD Memory Card state diagram (see Figure 16 and Figure 17) is associated with one operation mode.

Table 10. Card States vs. Operation Modes

| Card state | Operation mode |
|----------------------|--------------------------|
| Inactive State | Inactive |
| Idle State | Card Identification Mode |
| Ready State | |
| Identification State | |

Table 10. Card States vs. Operation Modes (continued)

| Card state | Operation mode |
|--------------------|--------------------|
| Stand-by State | Data Transfer Mode |
| Transfer State | |
| Sending-data State | |
| Receive-data State | |
| Programming State | |
| Disconnect State | |

3.4.1 Card Identification Mode

The host enters the Card Identification mode after reset and remains in this mode until it has finished searching for new cards on the bus.

Cards enter the Card Identification mode after reset and remain in this mode until they receive the SEND_RCA command (CMD3) (or the SET_RCA command for MultiMediaCards).

While in Card Identification mode the host resets all the cards that are in Card Identification mode, validates the operation voltage range, identifies every card and asks them to publish their Relative Card Addresses (RCA). This operation is done separately for each card on its own CMD line. In this mode, all data communications use the command line (CMD) only.

The host starts the card identification process at the identification clock rate f_{OD} . The SD Memory Card has push-pull CMD line output drives.

Once the bus has been activated the host asks each card to send their valid operation conditions (ACMD41 preceded by APP_CMD - CMD55 with RCA=0000h).

The response to ACMD41 is the Operation Condition Register of the card. The same command is sent to all the new cards in the system. Incompatible cards are switched to Inactive State.

The host then issues the ALL_SEND_CID command (CMD2), to every card to get their unique card identification (CID) numbers. All unidentified cards (which are in Ready State) answer by sending their CID numbers (on the CMD line) and switch to the Identification State. Then the host issues a CMD3 (SEND_RELATIVE_ADDR) command to ask the cards to publish a relative card address (RCA). The RCA is shorter than the CID, and will be used to address the card (typically at a clock rate higher than f_{OD}) once this is in Data Transfer mode. Once the RCA is received the card state changes to Standby. At this point, the host may ask the card to publish another RCA number by sending another SEND_RELATIVE_ADDR command to the card. The last published RCA is the actual RCA of the card.

The host repeats the identification process, that is the cycles with CMD2 and CMD3, for each card in the system. Once all the SD Memory Cards have been initialized, the host initializes the MultiMediaCards that are in the system (if any) by issuing CMD2 and CMD3 as explained in the MultiMediaCard specification. Note that in the SD system all the cards are connected separately so each MultiMediaCard has to be initialized individually.

Figure 11. SD Memory Card State Diagram (Card Identification Mode)

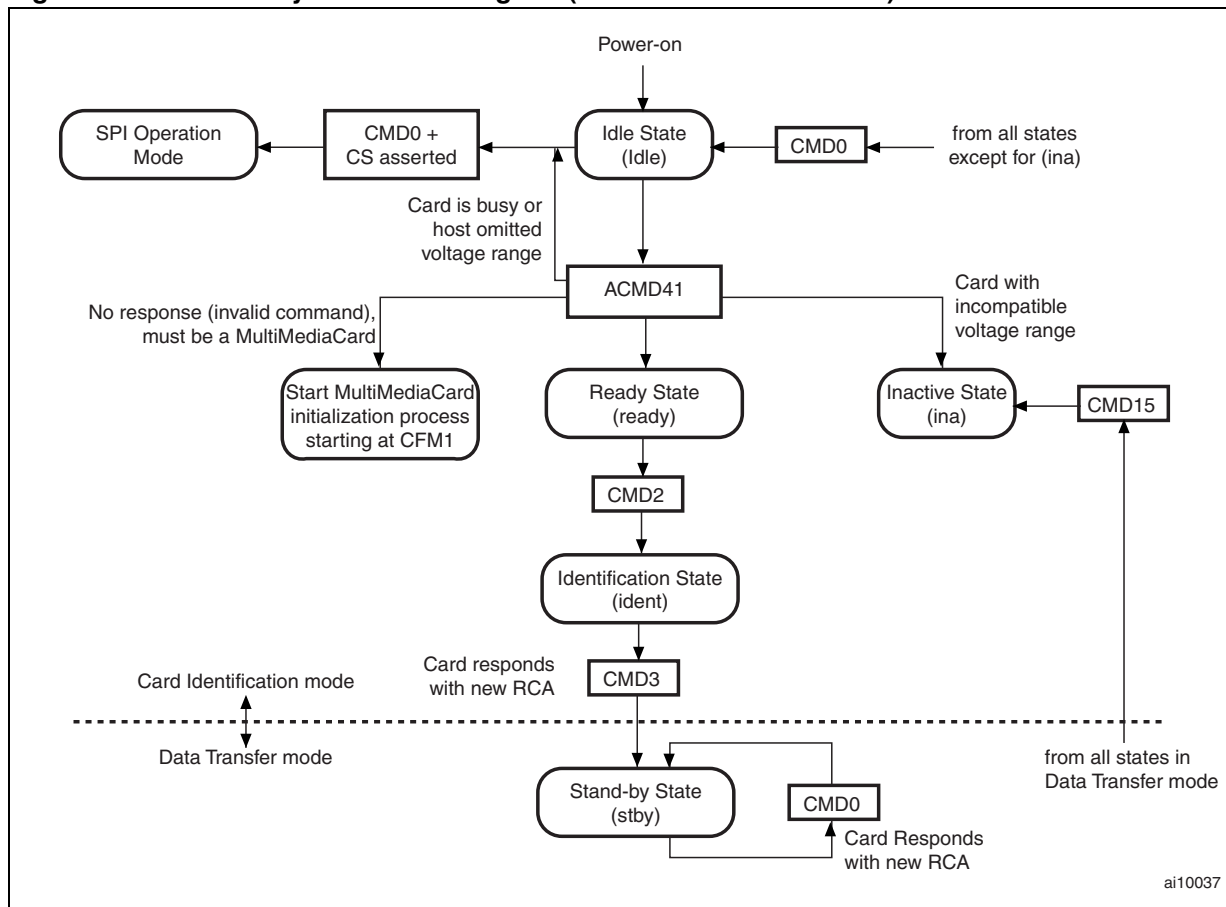

3.4.2 Data Transfer Mode

Cards enter the Data Transfer mode once their Relative Card Addresses (RCA) have been published.

The host enters the Data Transfer mode after identifying all the cards on the bus.

The host issues SEND_CSD (CMD9) to obtain the contents of the Card Specific Data (CSD) Register for each card. The CSD Register contains information like the block length and the card storage.

Until the host knows the contents of all the CSD Registers, the f_{PP} clock rate must remain at f_{OD} because some cards may have operating frequency limitations.

The broadcast command SET_DSR (CMD4) configures the driver stages of all identified cards. It programs their Driver Stage Registers (DSR) according to the application bus layout (length), the number of cards on the bus and the data transfer frequency. The clock rate is changed from f_{OD} to f_{PP} at that point. The SET_DSR command is an option for the card and the host.

CMD7 is used to select one card and switch it to the Transfer State. Only one card can be in Transfer State at a given time. If a previously selected card is still in Transfer State when the host uses CMD7 to switch another card to the Transfer state, then the connection between the previously selected card and the host is released and the card reverts to the Standby State.

When CMD7 is issued with the reserved relative card address "0000h", all cards revert to the Standby State. This function may be used before identifying new cards, to avoid resetting already registered cards. When in Standby state the cards that already have an RCA do not respond to identification commands (CMD41, CMD2, CMD3).

Note that a card is deselected when it receives a CMD7 with an RCA that does not match. Card deselection is automatic if another card in a system is selected and the cards share the same CMD lines.

So, in an SD Memory Card system, the host may either have a common CMD line for all SD Memory Cards (in which case card deselection is automatic just like in a MultiMediaCard system) or the host may have separate CMD lines, in which case it must be aware of the necessity of deselecting cards.

All data communications in the Data Transfer Mode are point-to-point between the host and the selected card (using addressed commands). All addressed commands are acknowledged by a response on the CMD line.

The relationships between the various states in the Data Transfer mode are summarized below (see [Figure 12](#)):

- All Data Read commands (CMD17, CMD18, CMD30, CMD56, ACMD51) can be aborted at any time using the Stop command (CMD12). The data transfer will terminate and the card will return to the Transfer State.
- All Data Write commands (CMD24, CMD25, CMD26, CMD27, CMD42, CMD56) can be aborted at any time using the Stop command (CMD12). The write commands must be stopped prior to deselecting the card using CMD7.
- As soon as the data transfer has completed, the card switches from the Data Write state to either the Programming state (if the transfer was successful) or the Transfer state (if the transfer failed).
- If a Block Write operation is stopped and the block length and CRC of the last block are valid, the data will be programmed.
- The card can provide buffering during Block Write. This means that the data to be programmed to the next block can be sent to the card while the previous block is being programmed.

If all write buffers are full, the DAT0 line will remain Low (BUSY) as long as the card is in the Programming state (see [Figure 12](#)).

- There is no buffering option for Write CSD, Write CID, Write Protection and erase. This means that while the card is busy with any one of these commands, no other Data Transfer command will be accepted. The DAT0 line will remain Low as long as the card is busy and in the Programming state.
- Parameter Set commands (CMD16, CMD32, CMD33) are not allowed while the card is programming.
- Read commands are not allowed while the card is programming.
- Switching another card from the Standby to the Transfer state (using CMD7) will not terminate erase and programming operations. The card will switch to the Disconnect state and release the DAT line.
- A card in the Disconnect state can be reselected using CMD7. The card will then revert to the Programming state and reactivate the busy signaling.
- Resetting a card (using CMD0 or CMD15) will terminate any pending or ongoing programming operation. This may result in the loss of card contents. It is up to the host to prevent possible data loss.

Figure 12. SD Memory Card State Diagram (Data Transfer Mode)

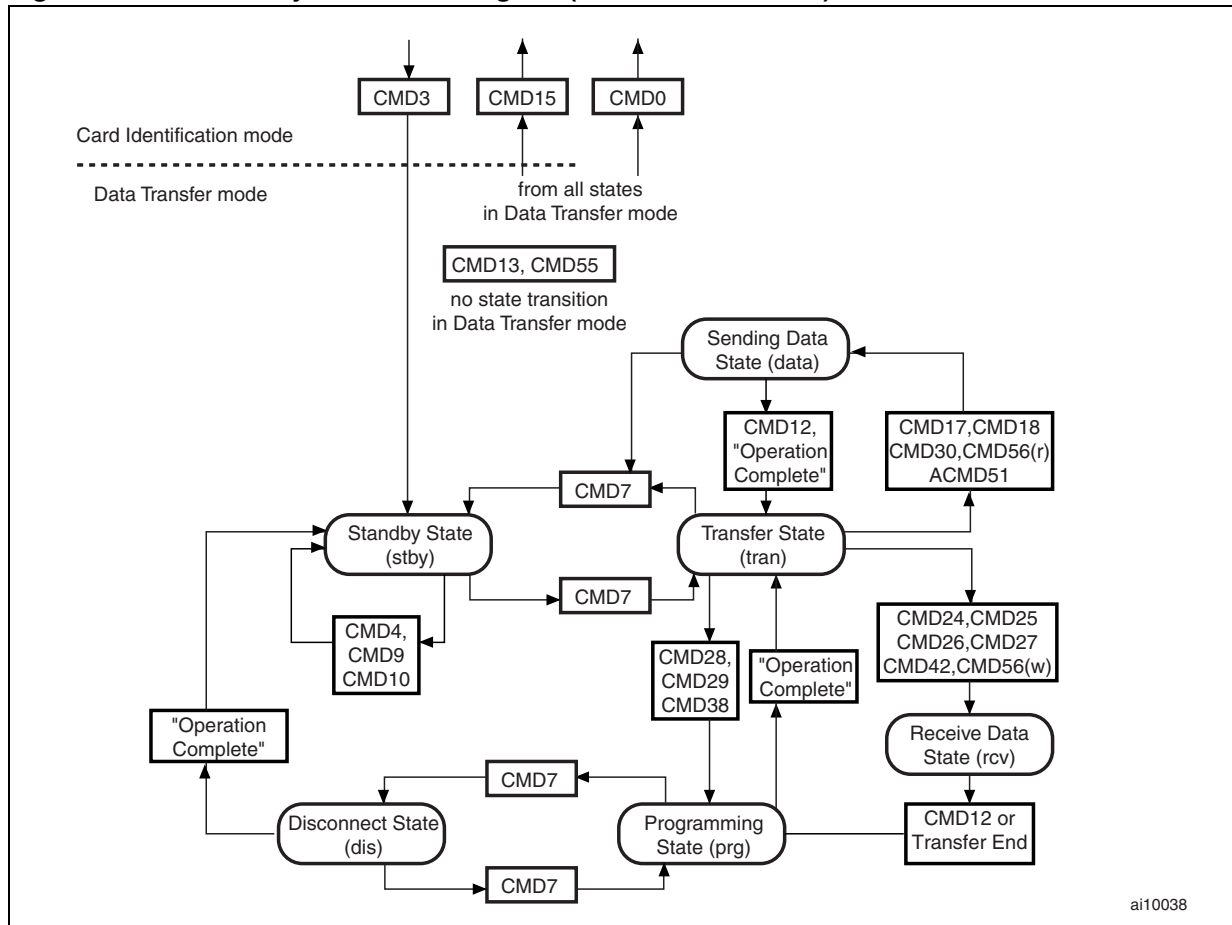

3.5 Commands

Four types of commands are used to control the SD Memory Card:

1. **Broadcast commands (bc), no response:** The broadcast feature is available only if all the CMD lines are interconnected at the level of the host. If they are not interconnected then each individual card will accept the command in turn.
2. **Broadcast commands with response (bcr):** Since there is no Open Drain mode in SD Memory Cards, this type of command is used only if the host does not use a common CMD line. The command is accepted by every individual Card and the responses from all cards are sent simultaneously.
3. **addressed (point-to-point) commands (ac):** There is no data transfer on DAT.
4. **addressed (point-to-point) data transfer commands (adtc):** There is a data transfer on DAT.

All commands have a fixed code length of 48 bits for a transmission time of 2.4 μ s at 20MHz. All commands and responses are sent over the CMD line of the SD Memory Card. Command transmission always starts with the most significant bit (MSB) of the command codeword. All commands are protected by a CRC. All Command codewords are terminated by the end bit (always '1'). [Table 11](#) shows the command format. All commands and their arguments are specified in the SD Memory Card Specification.

Table 11. SD Card Command Format

| Bit position | 47 | 46 | 45:40 | 39:8 | 7:1 | 0 |
|--------------|-----------|------------------|---------------|----------|------|---------|
| Width | 1 | 1 | 6 | 32 | 7 | 1 |
| Value | '0' | '1' | 'x' | x | x | '1' |
| Description | Start bit | Transmission bit | Command index | Argument | CRC7 | End bit |

3.6 Responses

All responses are sent via the command line CMD. Response transmission always starts with the leftmost bit of the response codeword. The code length depends on the response type. A response always starts with a start bit (always '0'), followed by the bit indicating the direction of transmission (from card = '0').

A value denoted by 'X' in [Table 12](#), [Table 13](#), [Table 14](#) and [Table 15](#) indicates a variable entry.

All responses (except for R3 Responses) are protected by a CRC. All response codewords are terminated by the end bit (always '1').

There are five types of responses. Their formats are defined as follows:

1. **R1 (normal response command):** the code length is 48 bits. Bits 45 to 40 indicate the index of the command to respond to. The index is a binary coded number (between 0 and 63). The status of the card is coded in 32 bits (see [Table 12](#)).
Note that if data transfer to the card takes place, then a busy signal may appear on the data line after the transmission of each block of data. The host has to check for busy after data block transmission.
2. **R1b** is identical to R1 with an optional busy signal transmitted on the data line. The card may become busy after receiving these commands, depending on the state it was in prior to receiving the command. The Host has to check for busy in the response.
3. **R2 (CID, CSD Register):** the code length is 136 bits. The contents of the CID Register are sent as a response to the CMD2 and CMD10 commands. The contents of the CSD Register are sent as a response to CMD9. Only the bits [127...1] of the CID and CSD Registers are transferred, the reserved bit [0] of these registers is replaced by the end bit of the response (see [Table 13](#)).
4. **R3 (OCR register):** the code length is 48 bits. The contents of the OCR register are sent as a response to ACMD41 (see [Section Table 14. on page 25](#)).
5. **R6 (Published RCA response):** the code length is 48 bits. Bits 45 to 40 indicate the index of the command to respond to. In this case it is '000011' (together with bit 5 in the status bits it means = CMD3) as shown in [Table 15](#) The 16 MSB bits of the argument field are used for the Published RCA number.

For more details about Response formats, please refer to the SD Memory Card Specification.

Table 12. Response R1

| Bit Position | 47 | 46 | [45:40] | [39:8] | [7:1] | 0 |
|--------------|-----------|------------------|---------------|-------------|-------|---------|
| Width (bits) | 1 | 1 | 6 | 32 | 7 | 1 |
| Value | '0' | '0' | X | X | X | '1' |
| Description | Start Bit | Transmission Bit | Command Index | Card Status | CRC7 | End Bit |

Table 13. Response R2

| Bit Position | 135 | 134 | [133:128] | [127:1] | 0 |
|--------------|-----------|------------------|-----------|---|---------|
| Width (bits) | 1 | 1 | 6 | 127 | 1 |
| Value | '0' | '0' | '111111' | X | '1' |
| Description | Start Bit | Transmission Bit | Reserved | CID or CSD register incl. internal CRC7 | End Bit |

Table 14. Response R3

| Bit Position | 47 | 46 | [45:40] | [39:8] | [7:1] | 0 |
|--------------|-----------|------------------|----------|--------------|----------|---------|
| Width (bits) | 1 | 1 | 6 | 32 | 7 | 1 |
| Value | '0' | '0' | '111111' | X | '111111' | '1' |
| Description | Start Bit | Transmission Bit | Reserved | OCR Register | Reserved | End Bit |

Table 15. Response R6

| Bit Position | 47 | 46 | [45:40] | [39:8] Argument Field | | [7:1] | 0 |
|--------------|-----------|------------------|--------------------------|---------------------------------------|---|-------|---------|
| Width (bits) | 1 | 1 | 6 | 16 | 16 | 7 | 1 |
| Value | '0' | '0' | X | X | X | X | '1' |
| Description | Start Bit | Transmission Bit | Command Index ('000011') | New published RCA [31:16] of the card | [15:0] Card Status Bits: 23, 22, 19 and 12 to 0 | CRC7 | end bit |

4 SD memory card hardware interface

4.1 SD memory card bus circuitry

Figure 13 shows the internal bus circuitry required for the Full Size SD Memory Card.

The SD Memory Card may also feature two additional contacts, that are not part of the internal circuitry. When present in the device, these contacts are located at the level of the Write Protect/Card Detect switch in the socket, and should be connected as illustrated in Figure 13.

When DAT3 is used for card detection, the R_{DAT} resistor connected to DAT3 should be disconnected and another resistor should be connected to Ground.

R_{DAT} and R_{CMD} are pull-up resistors used to protect the DAT and CMD lines, respectively, against bus floating when no card is inserted or when all card drivers are high impedance. R_{WP} is used to protect the Write Protect/Card Detection switch.

Figure 13. Full Size SD Memory Card Circuitry

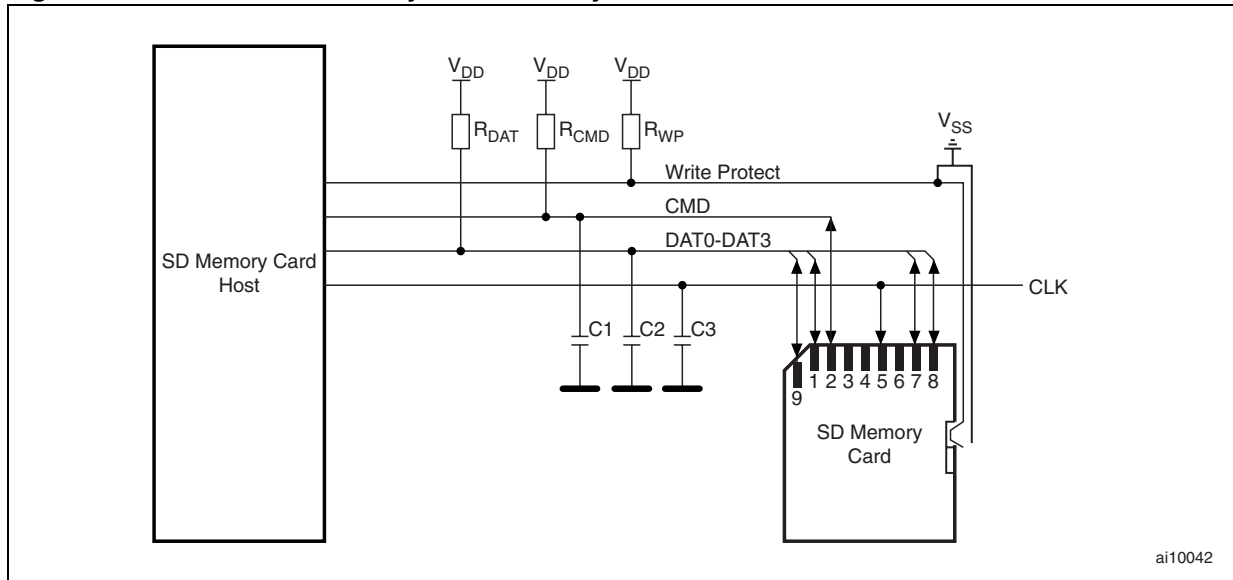

ai10042

4.2 Power-Up

The power-up of the SD Memory Card bus is handled locally in each SD Memory Card and in the bus master. After power-up (or after hot insertion) the SD Memory Card enters the Idle state. When in this state, the SD Memory Card ignores all bus transactions until ACMD41 is received (ACMD command type should always be preceded by CMD55).

ACMD41 is a special synchronization command used to negotiate the operating voltage range and to poll the cards until they are out of their power-up sequence. In addition to the operating voltage profile of the cards, the response to ACMD41 contains a busy flag that indicates that the power-up sequence has not completed and the card is not ready for identification. The host has to wait (and continue polling the cards in turn) until the bit is cleared ('0'). The power-up sequence of an individual card should not exceed 1 second.

After power-up the host starts the clock and sends the initializing sequence on the CMD line. This sequence is a contiguous stream of logical 1's. It does not exceed 1ms, 74 clocks or the supply-ramp-up-time.

Note that the maximum duration is fixed to 74 clocks which is ten clock cycles more than the 64 clocks after which the card is normally ready for communication to eliminate all power-up synchronization problems.

Figure 14. Power-Up Diagram

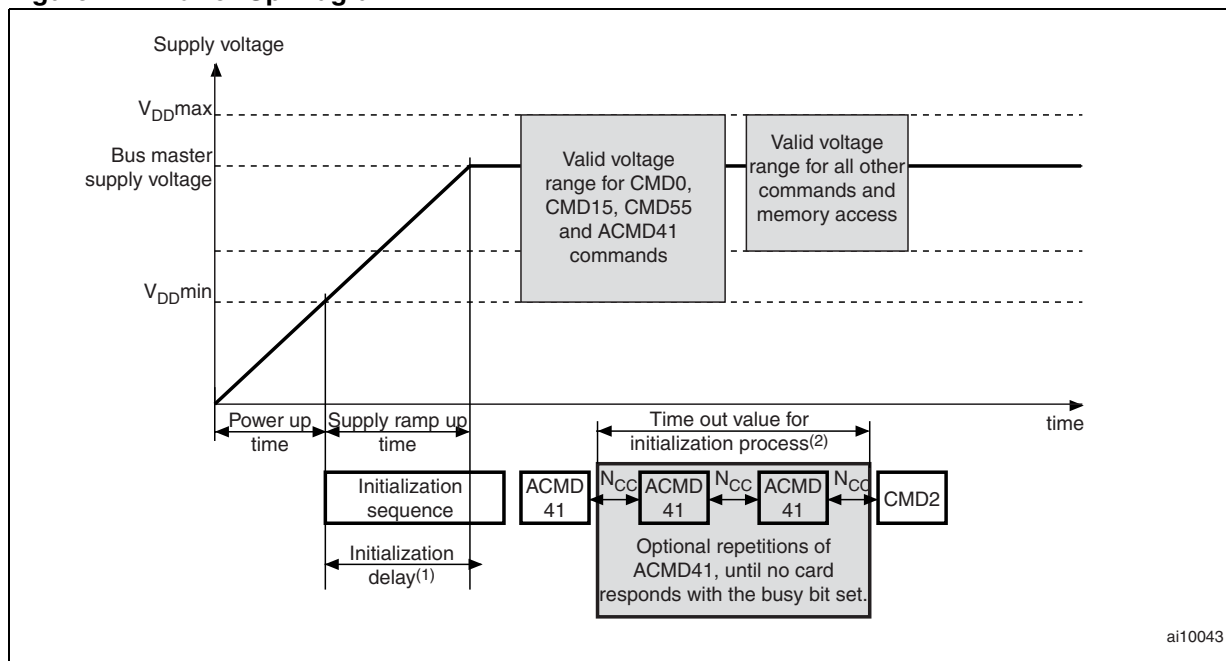

1. Initialization delay = 1ms (max) + 74 clock cycles + supply ramp-up time.
2. Timeout value for initialization process is 1s.

4.3 Hot Insertion/Removal

To guarantee a reliable initialization during hot insertion, some measures must be taken on by the host.

For example, a special hot-insertion capable card connector may be used to guarantee the sequence of the card pin connection.

The card contacts are connected in three steps:

1. Ground V_{SS} (pin 3) and supply voltage V_{DD} (pin 4).
2. CLK, CMD, DAT0, DAT1, DAT2 and V_{SS} (pin 6).
3. CD / DAT3 (pin 1).

Pins 3 and 4 should be connected first on insertion, and be disconnected last on extraction.

Another method is a switch which could ensure that the power is switched on only after all card pads are connected.

Inserting a Card in or removing it from the SD Memory Card bus with the power on will not damage the card. Data transfer operations are protected by CRC codes, therefore any bit changes induced by card insertion and removal can be detected by the SD Memory Card bus master.

- The inserted card must be properly reset even when the clock frequency is f_{PP}
- Each card should be fitted with a protection from the power supply to prevent damage to the card (and host).
- Data transfer failures induced by removal/insertion are detected by the bus master. They must be corrected by the application, which may repeat the issued command.

4.4 Power Protection

Cards have to be inserted in or removed from the bus without being damaged. If one of the supply pins (V_{DD} or V_{SS}) is not connected properly, then the current is drawn through a data line. All the card outputs should also be able to withstand shortcuts to either supply. If the hot insertion feature is implemented in the host, then the host has to be able to withstand an instant shortcut between V_{DD} and V_{SS} without being damaged.

4.5 Electrical Specifications

[Table 16](#) defines the Bus Operating Conditions for the SD Memory Card. The total capacitance C_L of the CLK line of the SD Memory Card bus is the sum of the bus master capacitance C_{HOST} , the bus capacitance C_{BUS} and the capacitances C_{CARD} of all the cards connected to this line.

$C_L = C_{HOST} + C_{BUS} + N \times C_{CARD}$, where:

- N is the number of cards connected to the line.
- $C_{HOST} + C_{BUS}$ must be lower than 30pF for up to 10 cards and lower than 40pF for up to 30 cards.
- The values in [Table 16](#) should not be exceeded.

As the bus can be supplied with a variable supply voltage, all signal levels are related to the supply voltage. See [Figure 15: Bus Signal levels](#) and [Table 17: Bus Signal Condition - I/O Signal Voltages](#).

Table 16. Bus Operating Conditions

| Symbol | Parameter | Min | Max. | Unit | Remark |
|--------------------|--|------|--------------|------------|-------------------------------------|
| | Peak voltage on all lines | -0.3 | $V_{DD}+0.3$ | V | |
| | Input Leakage Current | -10 | 10 | A | |
| | Output Leakage Current | -10 | 10 | A | |
| V_{DD} | Supply voltage | 2.0 | 3.6 | V | |
| | Supply voltage specified in OCR register | | | | |
| V_{SS1}, V_{SS2} | Supply voltage differentials | -0.3 | 0.3 | V | |
| | power-up time | | 250 | ms | |
| R_{CMD}, R_{DAT} | Pull-up resistance | 10 | 100 | K Ω | |
| C_L | Bus signal line capacitance | | 250 | pF | $f_{PP} < 5\text{MHz}$ 21 Cards |
| | | | 100 | pF | $f_{PP} < 20\text{MHz}$ 21 Cards |
| C_{CARD} | Single Card capacitance | | 10 | pF | |
| | Maximum signal line Inductance | | 16 | nH | $f_{PP} < 20\text{MHz}$ |
| R_{DAT3} | Pull-up resistance inside card (pin1) | 10 | 90 | K Ω | |

Figure 15. Bus Signal levels

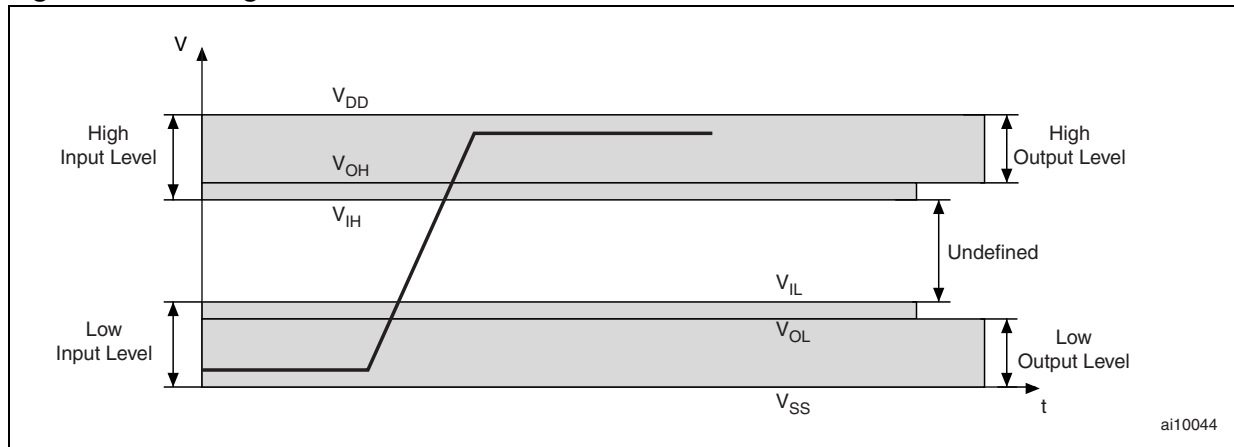
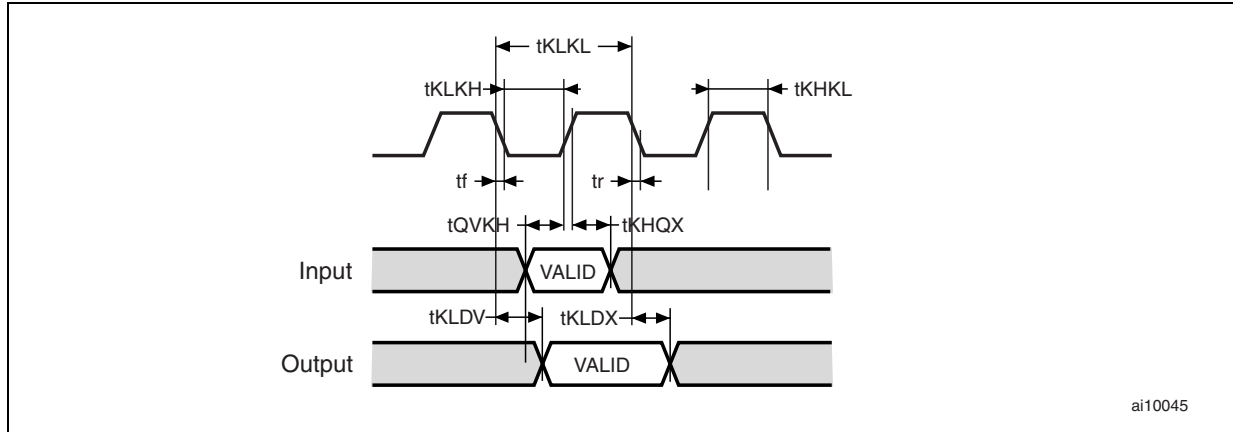

Table 17. Bus Signal Condition - I/O Signal Voltages

| Symbol | Parameter | Conditions | Min | Max. | Unit |
|----------|---------------------|--|----------------|----------------|------|
| V_{OH} | HIGH Output voltage | $I_{OH} = -100\mu\text{A}$ at V_{DD} min | $0.75V_{DD}$ | | V |
| V_{OL} | LOW Output voltage | $I_{OL} = 100\mu\text{A}$ at V_{DD} min | | $0.125V_{DD}$ | V |
| V_{IH} | HIGH Input voltage | | $0.625V_{DD}$ | $V_{DD} + 0.3$ | V |
| V_{IL} | LOW Input voltage | | $V_{SS} - 0.3$ | $0.25V_{DD}$ | V |

Figure 16. Data Input/Output Timings Referenced to Clock



ai10045

Table 18. Bus Timings (1)

| Symbol | Alt | Parameter | Condition | Min | Max. | Unit |
|---|------------|---|--------------------------|-----|------|------|
| t_{KLKL} | f_{PP} | Clock frequency Data Transfer Mode | $C_L = 100pF$ (7 cards) | 0 | 25 | MHz |
| f_{OD} | | Clock Frequency Identification Mode (the low frequency is required for MultiMediaCard compatibility). | $C_L = 250pF$ (21 cards) | 0 | 400 | kHz |
| t_{KLKH} | t_{WL} | Clock low time | $C_L = 100pF$ (7 cards) | 10 | | ns |
| | | | $C_L = 250pF$ (21 cards) | 50 | | ns |
| t_{KHKL} | t_{WH} | Clock high time | $C_L = 100pF$ (7 cards) | 10 | | ns |
| | | | $C_L = 250pF$ (21 cards) | 50 | | ns |
| t_r | t_{TLH} | Clock rise time | $C_L = 100pF$ (7 cards) | | 10 | ns |
| | | | $C_L = 250pF$ (21 cards) | | 50 | ns |
| t_f | t_{THL} | Clock fall time | $C_L = 100pF$ (7 cards) | | 10 | ns |
| | | | $C_L = 250pF$ (21 cards) | | 50 | ns |
| Inputs CMD, DAT (referenced to CLK) | | | | | | |
| t_{QVKH} | t_{ISU} | Input set-up time | $C_L = 25pF$ (1 card) | 5 | | ns |
| t_{KHQX} | t_{IH} | Input hold time | $C_L = 25pF$ (1 card) | 5 | | ns |
| Outputs CMD, DAT (referenced to CLK) | | | | | | |
| t_{KLDX} t_{KLDV} | t_{ODLY} | Output Delay time | $C_L = 25pF$ (1 card) | | 14 | ns |

1. Clock CLK: All values are referred to min (V_{IL}) and max (V_{IH}).

5 Card registers

Six registers are defined in the card interface: OCR, CID, CSD, RCA, DSR and SCR. See [Table 19](#) for a description.

The registers are accessed by using the corresponding commands. The OCR, CID, CSD and SCR registers contain the card/content specific information, whereas the RCA and DSR registers are configuration registers that store the actual configuration parameters.

For more details about the register structure, please refer to the SD Memory Card Specification v.1.01.

Table 19. SD Memory Card Registers

| Name | Width | Description |
|--------------------|-------|---|
| CID | 128 | Card Identification number register. It contains the card's individual identification number. It is mandatory. |
| RCA ⁽¹⁾ | 16 | Relative Card Address register. It contains the local system address of the card, that is dynamically suggested by the card and approved by the host during initialization. It is mandatory. |
| DSR | 16 | Driver Stage Register. It is used to configure the card's output drivers. It is optional. |
| CSD | 128 | Card Specific Data register. It contains the information about the card's operation conditions. It is mandatory. |
| SCR | 64 | SD Configuration Register. It contains the information about the SD Memory Card's Special Feature capabilities. It is mandatory. |
| OCR | 32 | Operation Condition Register. It is mandatory. |

1. The RCA Register is not used (available) in SPI mode.

5.1 OCR Register

The 32-bit Operation Conditions Register contains the V_{DD} voltage profile of the card. It also includes a status information bit that goes High (set to '1') once the card power-up sequence has completed. The OCR register is used by the cards that do not support the full operating voltage range of the SD Memory Card bus, or by cards whose power-up sequence does not match the definition given in [Figure 14: Power-Up Diagram](#).

Table 20. OCR Register Definition

| OCR Bit Position | V_{DD} Voltage Range |
|------------------|------------------------|
| 0-3 | reserved |
| 4 | 1.6V to 1.7V |
| 5 | 1.7V to 1.8V |
| 6 | 1.8V to 1.9V |
| 7 | 1.9V to 2.0V |
| 8 | 2.0V to 2.1V |

Table 20. OCR Register Definition (continued)

| OCR Bit Position | V _{DD} Voltage Range |
|------------------|---|
| 9 | 2.1V to 2.2V |
| 10 | 2.2V to 2.3V |
| 11 | 2.3V to 2.4V |
| 12 | 2.4V to 2.5V |
| 13 | 2.5V to 2.6V |
| 14 | 2.6V to 2.7V |
| 15 | 2.7V to 2.8V |
| 16 | 2.8V to 2.9V |
| 17 | 2.9V to 3.0V |
| 18 | 3.0V to 3.1V |
| 19 | 3.1V to 3.2V |
| 20 | 3.2V to 3.3V |
| 21 | 3.3V to 3.4V |
| 22 | 3.4V to 3.5V |
| 23 | 3.5V to 3.6V |
| 24-30 | reserved |
| 31 | Card Power-up Status bit (busy). This bit is Low during the card power-up routine. It goes High on completion |

5.2 CID Register

The Card IDentification (CID) Register contains the card identification information used during the card identification phase. Each Flash memory card should have a unique identification number. The structure of the CID register is defined in [Figure 16](#).

Table 21. CID Fields

| Name | Field | Width | CID-slice |
|-----------------------|-------|-------|-----------|
| Manufacturer ID | MID | 8 | [127:120] |
| OEM/Application ID | OID | 16 | [119:104] |
| Product name | PNM | 40 | [103:64] |
| Product revision | PRV | 8 | [63:56] |
| Product serial number | PSN | 32 | [55:24] |
| Reserved | -- | 4 | [23:20] |
| Manufacturing date | MDT | 12 | [19:8] |
| CRC7 checksum | CRC | 7 | [7:1] |
| not used, always '1' | -- | 1 | [0:0] |

5.3 CSD Register

The Card Specific Data Register provides information on how to access the card contents. The CSD Register defines the data format, error correction type, maximum data access time, data transfer speed, whether the DSR register can be used etc. The programmable register parameters (entries with cell type W or R, listed in [Table 22](#)) can be changed using CMD27.

Table 22. CSD Fields Compatible with CSD Structure V1 / MM Card Specification V2.11

| Name | Field | Width | Cell Type ⁽¹⁾ | CSD-slice |
|--|--------------------|-------|--------------------------|-----------|
| CSD structure | CSD_STRUCTURE | 2 | R | [127:126] |
| reserved | - | 6 | R | [125:120] |
| data read access-time-1 | TAAC | 8 | R | [119:112] |
| data read access-time-2 in CLK cycles (NSAC*100) | NSAC | 8 | R | [111:104] |
| Max. data transfer rate | TRAN_SPEED | 8 | R | [103:96] |
| card command classes | CCC | 12 | R | [95:84] |
| Max. read data block length | READ_BL_LEN | 4 | R | [83:80] |
| partial blocks for read allowed | READ_BL_PARTIAL | 1 | R | [79:79] |
| write block misalignment | WRITE_BLK_MISALIGN | 1 | R | [78:78] |
| read block misalignment | READ_BLK_MISALIGN | 1 | R | [77:77] |
| DSR implemented | DSR_IMP | 1 | R | [76:76] |
| reserved | - | 2 | R | [75:74] |
| device size | C_SIZE | 12 | R | [73:62] |
| Max. read current @VDD min | VDD_R_CURR_MIN | 3 | R | [61:59] |
| Max. read current @VDD max | VDD_R_CURR_MAX | 3 | R | [58:56] |
| Max. write current @VDD min | VDD_W_CURR_MIN | 3 | R | [55:53] |
| Max. write current @VDD max | VDD_W_CURR_MAX | 3 | R | [52:50] |
| device size multiplier | C_SIZE_MULT | 3 | R | [49:47] |
| erase single block enable | ERASE_BLK_EN | 1 | R | [46:46] |
| sector size | SECTOR_SIZE | 7 | R | [45:39] |
| write protect group size | WP_GRP_SIZE | 7 | R | [38:32] |
| write protect group enable | WP_GRP_ENABLE | 1 | R | [31:31] |
| reserved for MultiMediaCard compatibility | - | 2 | R | [30:29] |
| write speed factor | R2W_FACTOR | 3 | R | [28:26] |
| Max. write data block length | WRITE_BL_LEN | 4 | R | [25:22] |
| partial blocks for write allowed | WRITE_BL_PARTIAL | 1 | R | [21:21] |
| reserved | - | 5 | R | [20:16] |
| File format group | FILE_FORMAT_GRP | 1 | R/W(1) | [15:15] |
| copy flag (OTP) | COPY | 1 | R/W(1) | [14:14] |
| permanent write protection | PERM_WRITE_PROTECT | 1 | R/W(1) | [13:13] |

Table 22. CSD Fields Compatible with CSD Structure V1 / MM Card Specification V2.11

| Name | Field | Width | Cell Type ⁽¹⁾ | CSD-slice |
|----------------------------|-------------------|-------|--------------------------|-----------|
| temporary write protection | TMP_WRITE_PROTECT | 1 | R/W | [12:12] |
| File format | FILE_FORMAT | 2 | R/W(1) | [11:10] |
| reserved | - | 2 | R/W | [9:8] |
| CRC | CRC | 7 | R/W | [7:1] |
| not used, always '1 | - | 1 | - | [0:0] |

1. R = readable, W(1) = can be written once, W = can be written several times.

5.4 RCA Register

The writable 16-bit Relative Card Address Register contains the card address published by the card during the identification phase. This address is used for addressed host-card communications after the card identification phase. The default value of the RCA register is 0000h. This value is reserved, the CMD7 command uses it to set all the cards to the Standby state.

5.5 DSR Register (Optional)

The 16-bit Driver Stage Register is not used in Numonyx Cards.

5.6 SCR Register

The SD Card Configuration Register (SCR) is a configuration register. The SCR provides information on the special features that are configured in the SD Memory Card. The size of SCR Register is 64 bit.

This register is programmed in the factory by the SD Memory Card manufacturer. [Table 23](#) describes the SCR contents.

Table 23. SCR Fields

| Description | Field | Width | Cell Type ⁽¹⁾ | SCR Slice |
|---|-----------------------|-------|--------------------------|-----------|
| SCR Structure | SCR_STRUCTURE | 4 | R | [63:60] |
| SD Memory Card - Specification. Version | SD_SPEC | 4 | R | [59:56] |
| data_status_after erases | DATA_STAT_AFTER_ERASE | 1 | R | [55:55] |
| SD Security Support | SD_SECURITY | 3 | R | [54:52] |
| DAT Bus width supported | SD_BUS_WIDTHS | 4 | R | [51:48] |
| reserved | - | 16 | R | [47:32] |
| reserved for manufacturer usage | - | 32 | R | [31:0] |



1. R = readable.

6 Timings

The symbols listed in [Table 24](#) are used in all timing diagrams.

The difference between P-bits and Z-bits is that P-bits are actively driven to High by the card or the host output driver whereas Z-bits are driven to High and kept High by the pull-up resistors R_{CMD} and R_{DAT} . P-bits, which are actively driven High, are less sensitive to noise. All timing values are defined in [Table 25](#)

Table 24. Timing Diagram Symbols

| Symbol | Description |
|---|--|
| S | Start bit (= '0') |
| T | Transmitter bit (Host = '1', Card = '0') |
| P | One-cycle pull-up (= '1') |
| E | End bit (=1) |
| Z | High impedance state (-> = '1') |
| D | Data bits |
| X | Don't Care data bits (from card) |
| * | Repetition |
| CRC | Cyclic redundancy check bits (7 bits) |
|  | Card active |
|  | Host active |

6.1 Command and Response

The host command and the card response are both clocked out on the rising edge of the host clock.

6.1.1 Card Identification and Operating Conditions Timings

The timings for CMD2 (ALL_SEND_CID) and ACMD41 are shown in [Figure 17](#). The command is followed by two Z-bits (to leave time for the bus to switch direction) and then by P-bits pushed up by the responding card. The card response to the host command starts after N_{ID} clock cycles.

Figure 17. Identification Sequence

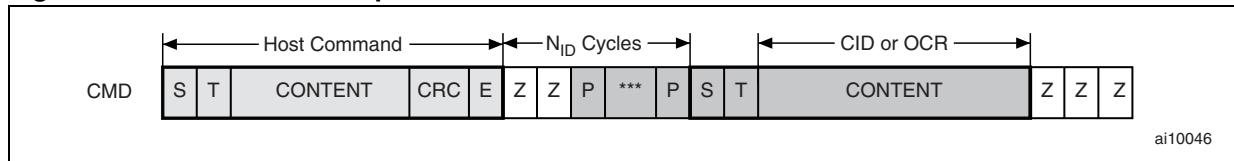

6.1.2 Card Relative Address Timings

The SD Memory Card timings for CMD3 (SEND_RELATIVE_ADDR) are given in [Figure 18](#). The minimum delay between the host command and the card response is N_{CR} clock cycles.

Figure 18. SEND_RELATIVE_ADDRESS Command

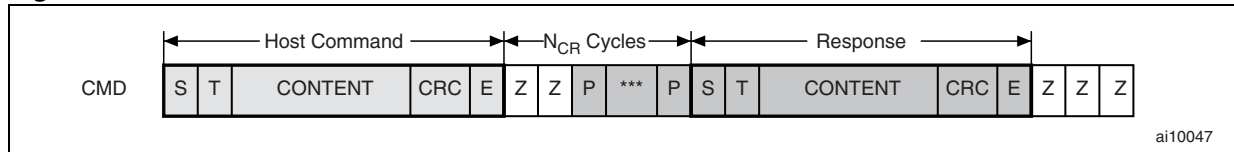

6.1.3 Data Transfer Mode

After publishing its RCA the card switches to the Data Transfer mode. The command is followed by two Z-bits (to leave time for the bus to switch direction) and then by P-bits pushed by the responding card as shown in [Figure 19](#). The timing diagram presented in [Figure 19](#) applies to all host commands followed by card responses, and to ACMD41 and CMD2 commands.

Figure 19. Response (Data Transfer Mode)

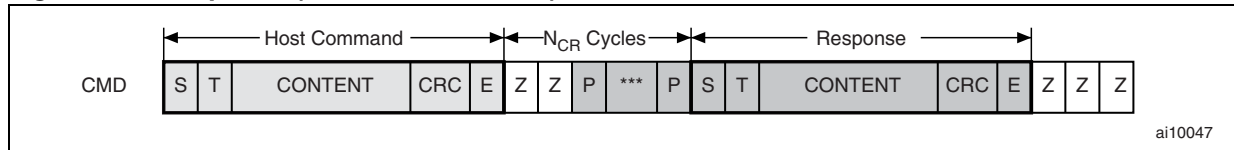

6.1.4 Last Card Response, Next Host Command Timings

After receiving the last card response, the host can start the next command transmission after N_{RC} clock cycles as shown in [Figure 20](#). The timing diagram presented in [Figure 20](#) applies to any host command.

Figure 20. Response End To Next CMD Start (Data Transfer Mode)

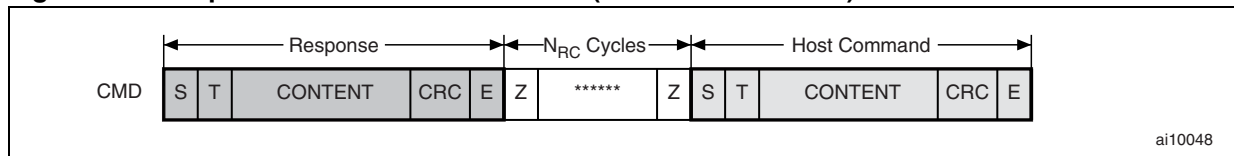

6.1.5 Last Host Command, Next Host Command Timings

The host can send a new command N_{CC} clock cycles after sending the previous one as shown in [Figure 21](#).

Figure 21. Command Sequence (All Modes)

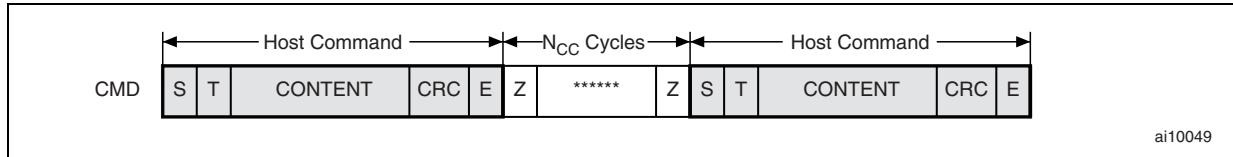

6.2 Data Read

6.2.1 Single Block Read

The host selects one card for the data read operation by issuing CMD7, and sets the valid block length for oriented data transfer by issuing CMD16. [Figure 22](#) shows the timings for a basing bus read operation. The sequence starts with a Single Block Read command (CMD17) which specifies the start address in the argument field. The response is sent on the CMD line.

Data transmission from the card starts N_{AC} after the end bit of the read command, where N_{AC} is the access time. CRC check bits are appended to the data bits to allow the host to check for transmission errors.

Figure 22. Single Block Read Command

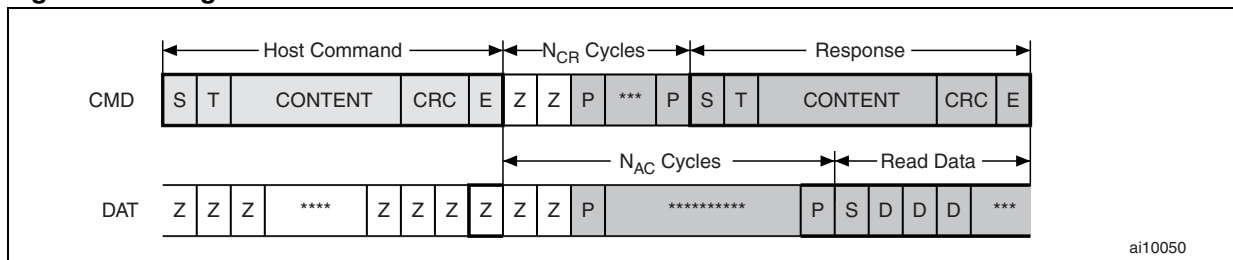

6.2.2 Multiple Block Read

In Multiple Block Read mode, the card responds to the read command from the host by sending a continuous flow of data blocks. The data flow is terminated by a STOP_TRANSMISSION command (CMD12). [Figure 23](#) describes the Multiple Block Read command followed by the data blocks and [Figure 24](#), the response to a STOP_TRANSMISSION command. The data transmission stops two clock cycles after the end bit of the STOP_TRANSMISSION command.

Figure 23. Multiple Block Read Command

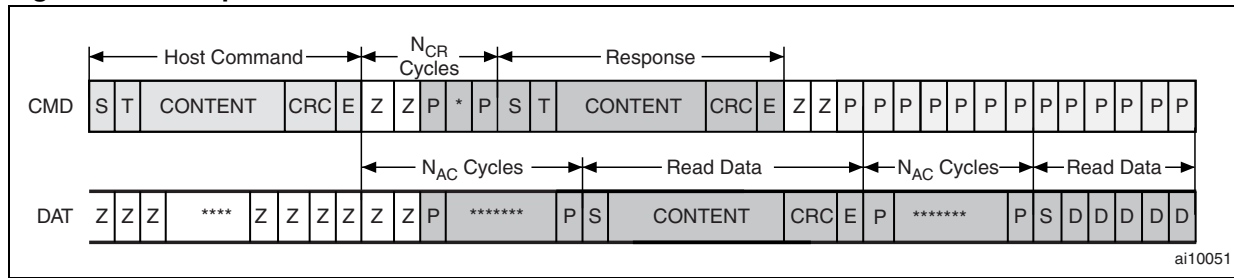
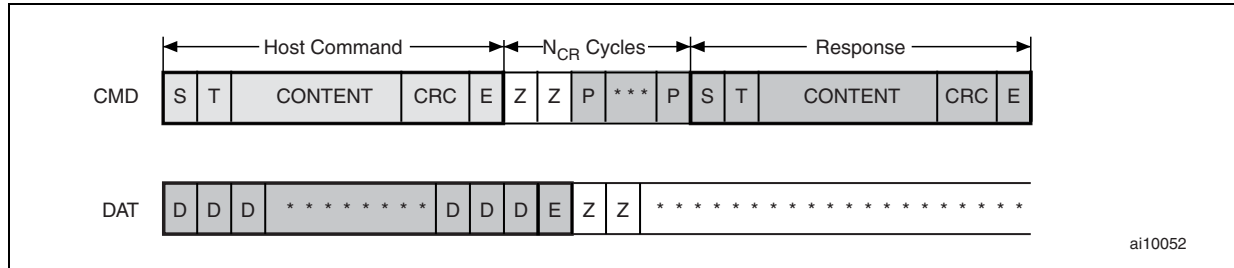

Figure 24. STOP_TRANSMISSION Command (CMD12, Data Transfer Mode)



6.3 Data Write

6.3.1 Single Block Write

The host selects one card for the data write operation by issuing CMD7. The host sets the valid block length for block oriented data transfer by issuing CMD16. Figure 25 shows the timings of a basic bus write operation. The sequence starts with a Single Block Write command (CMD24) which determines (in the argument field) the start address. The card responds on the CMD line.

Data transfer from the host starts N_{WR} clock cycles after the card response is received. CRC check bits are appended to the data sent by the host to allow the card to check for transmission errors. The card returns the CRC check result as a CRC status token on the DAT0 line. If a transmission error occurred, the card returns a negative CRC status ('101'). If the transmission completed successfully, the card returns a positive CRC status ('010') and starts programming the data.

If an error occurred while programming the Flash memory, the card ignores all further data blocks. In this case the card will not send any CRC response and so, there will be no CRC start bit on the bus and the three CRC status bits will read ('111').

Note that the CRC response is always output two clock cycles after the data.

If the card does not have any Data Receive buffer available, it indicates this condition by pulling the DAT0 data line to Low. It will stop pulling DAT0 to Low as soon as at least one Data Receive buffer for the defined data transfer block length becomes available. The level of DAT0 does not give any information about the data write status. The host can obtain this information by issuing a CMD13 (SEND_STATUS) to the card.

Figure 25. Block Write Command

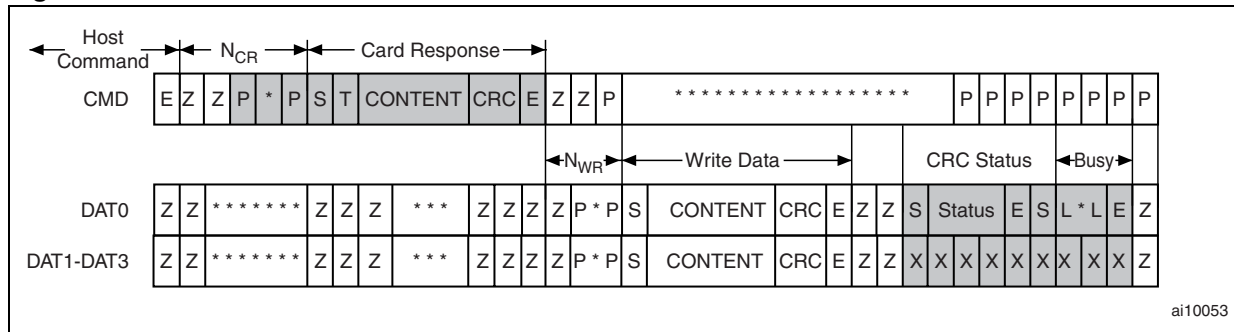

6.3.2 Multiple Block Write

In Multiple Block Write mode, the write command from the host is followed by a continuous flow of data blocks from the host. The data flow is terminated by a STOP_TRANSMISSION command (CMD12).

As in the case of a Single Block Write operation, CRC check bits are appended to the data sent to allow the card to check for transmission errors. The card returns the CRC check result as a CRC status token on the DAT0 line.

If a transmission error occurred, the card returns a negative CRC status ('101'). If the transmission completed successfully, the card returns a positive CRC status ('010') and starts programming the data.

If an error occurred while programming the Flash memory, the card ignores all further data blocks. In this case the card will not send any CRC response and so, there will be no CRC start bit on the bus and the three CRC status bits will read ('111').

Figure 26 describes a Multiple Block data transmission with and without a card busy signal.

Figure 26. Multiple Block Write Command

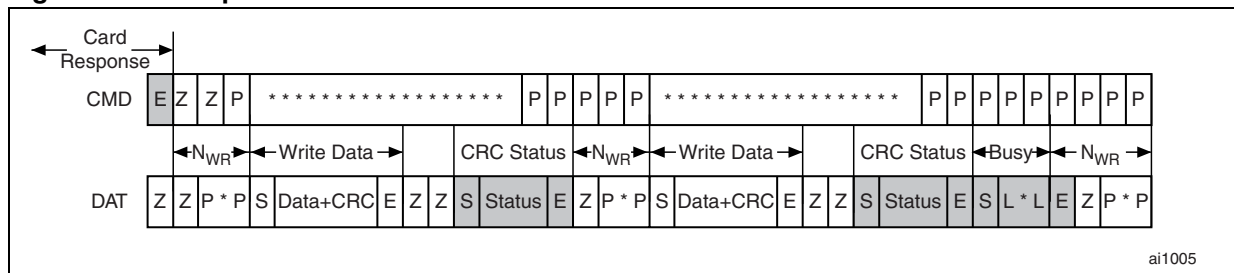

6.4 STOP_TRANSMISSION Command

The STOP_TRANSMISSION command works in the same way as in the read mode. Figure 27 to Figure 30 describe the timings of the STOP_TRANSMISSION command in different card states.

The card will consider that a data block was successfully received and is ready for programming only if the CRC data of the block was validated and the CRC status token, returned to the host.

Figure 28 is an example of an interrupted (by a STOP_TRANSMISSION command from the host) attempt to transmit the CRC status token. The result is the same as in other examples

where the STOP_TRANSMISSION command is implemented: the end bit of the STOP_TRANSMISSION command from the host is followed, on the data line, by one more data bit, then an end bit and two Z-bits. The two Z-bits, which correspond to two clock cycles, are used to switch the bus direction. The received data block is considered incomplete and will not be programmed.

In the previous Stop Transmission examples, the host stopped the data transmission during an active data transfer.

In [Figure 29](#) and [Figure 30](#) the STOP_TRANSMISSION command is received by the card after all the data blocks have been sent.

In [Figure 29](#), the card is busy programming the last block when the STOP_TRANSMISSION command is received whereas in [Figure 30](#) the card is idle but the input buffers still contain data blocks to be programmed. In the second case, the card starts programming the blocks upon reception of the STOP_TRANSMISSION command and activates the busy signal.

Figure 27. STOP_TRANSMISSION During Data Transfer From The Host

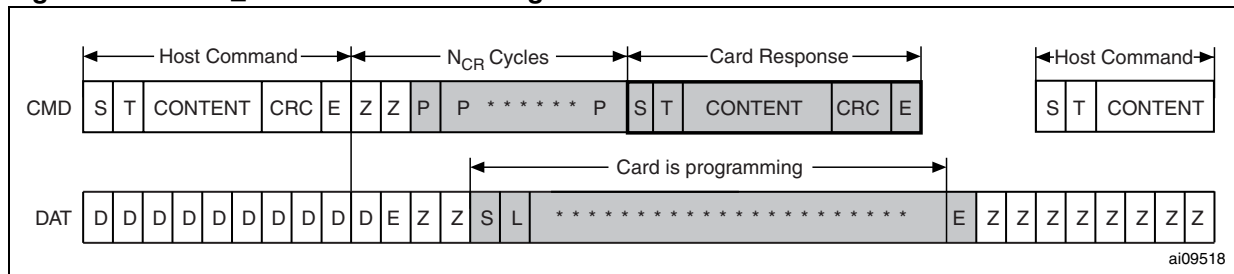
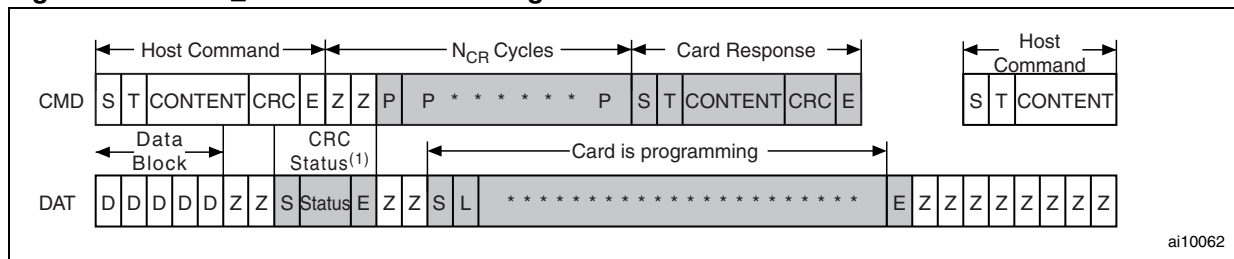

Figure 28. STOP_TRANSMISSION During CRC Status Transfer From Card



1. The card CRC status response was interrupted by the host.

Figure 29. STOP_TRANSMISSION Received After Last Data Block with Card Busy Programming

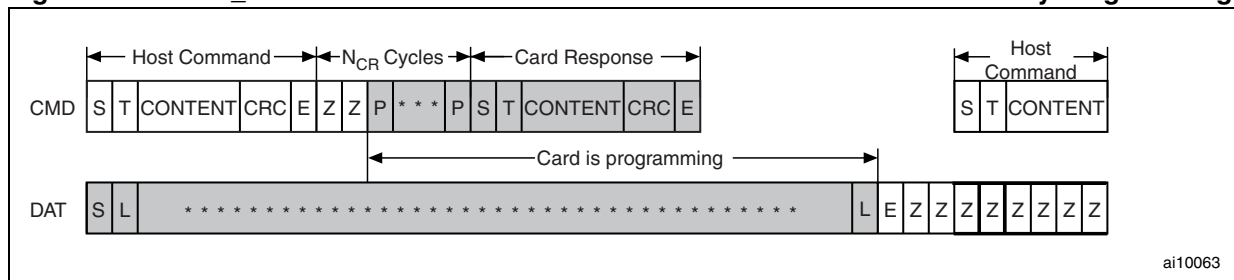
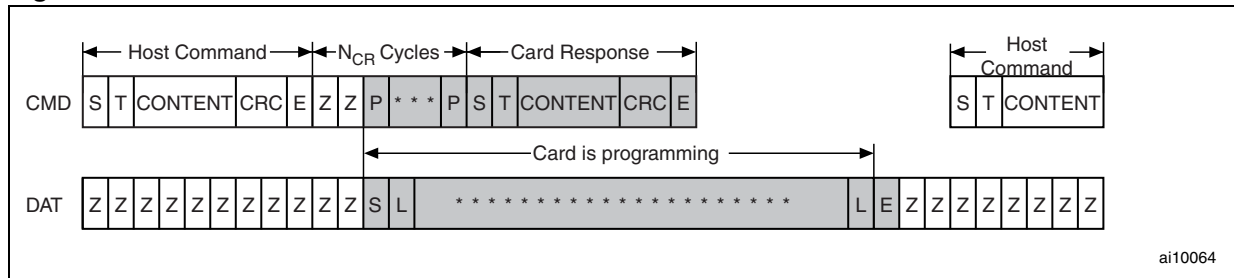

Figure 30. STOP_TRANSMISSION Received After Last Data Block with Card Idle



6.4.1 Erase, Set and Clear Write Protect Timings

The host must first tag the start (CMD32) and end (CMD33) addresses of the range to be erased. The Erase command (CMD38), once issued, will erase all the selected write blocks. Similarly, Set and Clear Write Protect commands start a programming operation as well. The card will signal "busy" (by pulling the DAT line Low) for the duration of the erase or program operation. The bus transaction timings are the same as those given for the STOP_TRANSMISSION Command in [Figure 30](#).

6.4.2 Re-selecting a busy card

When a busy card in Disabled state is reselected, it restores its busy signaling on the data line. The timing diagram for this command / response / busy transaction is the same as that for STOP_TRANSMISSION command illustrated in [Figure 30](#).

6.5 Timing Values

[Figure 25](#) gives all timings.

Table 25. Timing Values

| Parameter | Min | Max | Unit |
|-----------------|-----|-------------------------------------|-------------|
| N _{CR} | 2 | 64 | clock cycle |
| N _{ID} | 5 | 5 | clock cycle |
| N _{AC} | 2 | T _{AAC} + N _{SAC} | clock cycle |
| N _{RC} | 8 | - | clock cycle |
| N _{CC} | 8 | - | clock cycle |
| N _{WR} | 2 | - | clock cycle |

7 Serial peripheral interface (SPI) mode

The SPI mode is a secondary communication protocol, which is available in Flash memory-based SD Memory Cards. The SD Memory Card SPI implementation uses a subset of the SD Memory Card protocol and command set. The advantage of the SPI mode is the capability of using off-the-shelf host, hence reducing the design-in effort to a minimum. The disadvantage is the loss of performance (e.g., Single data line and hardware \overline{CS} signal per card). The SPI mode is selected during the first Reset command after power-up (CMD0) and cannot be changed once the part is powered on.

7.1 SPI bus topology

The SPI compatible communication mode of the SD Memory Card is designed to communicate with an SPI channel, commonly found in various microcontrollers on the market. The SPI standard defines the physical link only, and not the complete data transfer protocol. The SD Memory Card SPI and SD modes use the same command set.

Like all SPI devices, the SD Memory Card SPI channel uses the four following signals:

- \overline{CS} : Host to card Chip Select signal.
- CLK: Host to card clock signal
- DataIn: Host to card data signal.
- DataOut: Card to host data signal.

All data tokens are multiples of Bytes (8 bits) and always Byte-aligned to the \overline{CS} signal. The card identification and addressing methods are replaced by a hardware Chip Select (\overline{CS}) signal. There are no broadcast commands. For every command, a card (slave) is selected by asserting (active Low) the \overline{CS} signal (see [Figure 31: SD Memory Card System SPI Mode Bus Topology](#)). The \overline{CS} signal must be continuously active for the duration of the SPI transaction. The only exception occurs during card programming, when the host can de-assert the \overline{CS} signal without affecting the programming process. The SPI interface uses 7 out of the 9 SD signals (DAT1 and DAT2 are not used, DAT3 is the \overline{CS} signal) of the SD bus.

Figure 31. SD Memory Card System SPI Mode Bus Topology

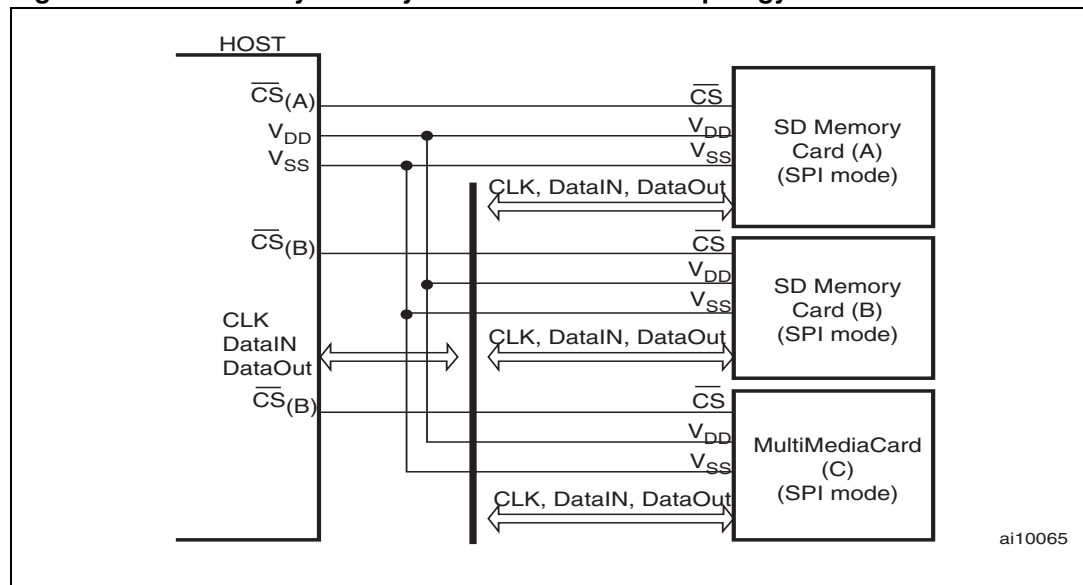

7.2 SPI Bus Protocol

Whereas the SD channel is based on command and data bit streams initiated by a start bit and terminated by a stop bit, the SPI channel is Byte-oriented. Every command or data block is built up with 8-bit Bytes and is Byte-aligned to the \overline{CS} signal (that is, the length is a multiple of 8 clock cycles).

Like in the SD protocol, messages in the SPI protocol consist of command, response and data-block tokens. All communications between host and cards are controlled by the host (master). The host starts every bus transaction by asserting the \overline{CS} signal Low.

The response behaviors in SPI mode and SD mode differ in three ways. In the SPI mode:

- the selected card always responds to the command.
- two additional (8 & 16 bit) response structures are used
- when the card encounters a data retrieval problem, it sends an error response in place of the expected data block (in the SD mode the card does not respond but implements a timeout).

In addition to returning a response for every command received, the card returns a special data response token for every data block received during write operations.

7.2.1 Mode Selection

The SD Memory Card wakes up in the SD mode. It will enter the SPI mode if the \overline{CS} signal is asserted (Low) when the Reset command (CMD0) is received.

The only way to return to the SD mode is to start a new power-down/power-up sequence.

In SPI mode, the SD Card protocol state machine does not apply.

7.2.2 Bus Transfer Protection

On entering the SPI mode the card defaults to the non-protected mode where there is no CRC (Cyclic Redundancy Check). So systems using reliable data links are not obliged to have the hardware and firmware necessary to implement CRC functions.

In non-protected mode, the CRC bits are still present but are Don't Care. The CRC option can be turned on and off by the host through the CRC_ON_OFF command (CMD59).

7.2.3 Data Read

Single and Multiple Block Read operations are supported in SPI mode. The main difference with the SD mode is that in SPI mode data and responses to the host are both sent on the DataOut line. As a consequence the data transfer may be interrupted and the last data block, replaced by the response to a STOP_TRANSMISSION command.

The basic unit of data transfer is the block. The maximum size of a block is defined in the CSD Register (READ_BL_LEN).

If READ_BL_PARTIAL is set, smaller blocks entirely contained in a physical block (as defined by READ_BL_LEN) may also be transmitted. Single Block Read operations are initiated by issuing the READ_SINGLE_BLOCK command (CMD17). The start address can be any Byte in the valid address range of the card. Every block, however, must be contained in a single physical card sector.

Multiple Block Read operations are initiated by issuing the READ_MULTIPLE_BLOCK command (CMD18) and every transferred block has a 16-bit CRC appended to it. The STOP_TRANSMISSION command (CMD12) will actually stop the data transfer operation (just like in the SD mode).

Figure 32. Read Operation Mechanism

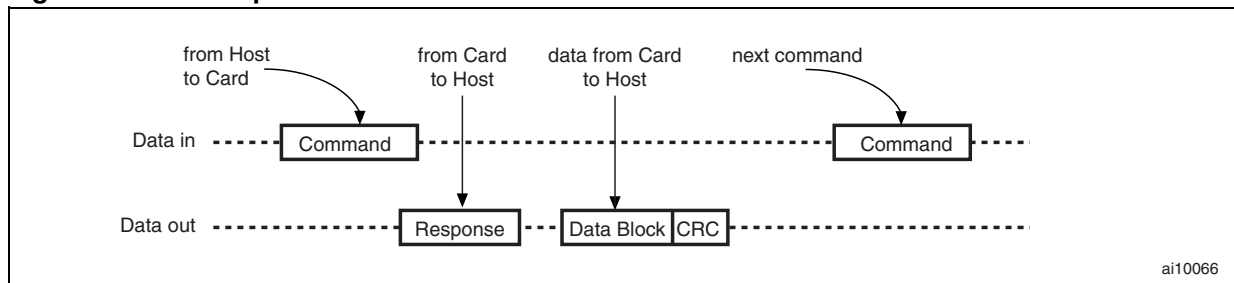

Figure 33. Multiple Block Read Operation

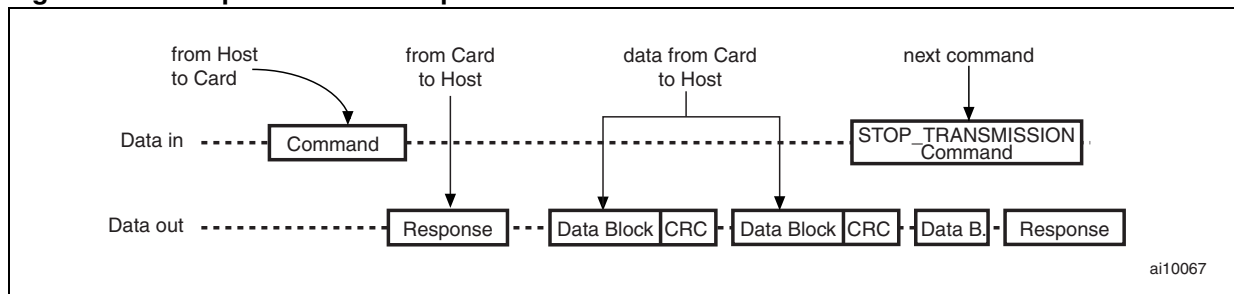
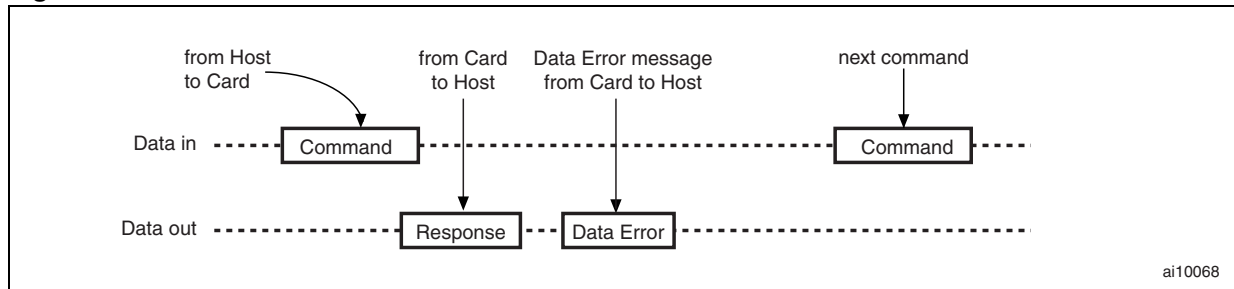

Figure 34. Read Data Error



7.2.4 Data Write

Single and Multiple Block Write operations are supported in SPI mode.

Upon reception of a valid write command, the card sends a response token and waits for a data block to be sent from the host. Write operations, as illustrated in [Figure 35.](#), follow the same rules as Read operations (refer to [Section 7.2.4: Data Write](#)) as regards the CRC, block length and start address.

After receiving a data block, the card returns a data response token. If the data block received contains no error, it is programmed. Throughout the programming operation the card sends a continuous stream of busy tokens to the host (by holding the DataOut line Low).

Figure 35. Write Operation

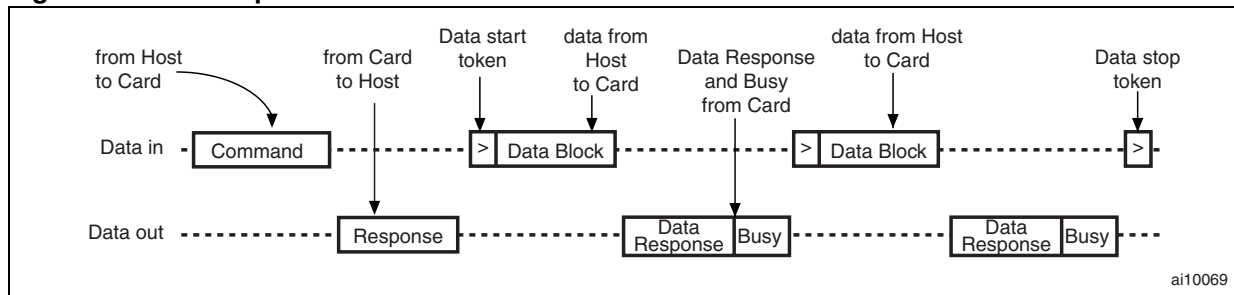

7.2.5 Erase & Write Protect Management

The erase and write protect management procedures are the same in the SPI and SD modes.

While the card is erasing or changing the write protection bits, it remains in the busy state and holds the DataOut line Low.

Figure 36. Erase & Write Protect Operations

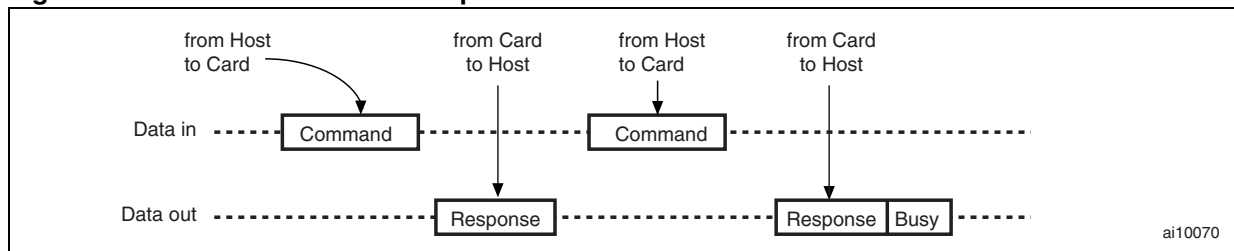

7.2.6 Read CID/CSD Registers

In SPI mode the CID and CSD Registers use a Block Read operation. When a Read command is issued, the card returns a response message followed by a 16 Byte data block with a 16-bit CRC.

As T_{AAC} , the Data Read Access Time, is stored in the CSD Register, it cannot be used as the read latency of the CSD Register. N_{CR} (see [Table 25: Timing Values](#)) is used instead.

7.2.7 Reset Sequence

The SD Memory Card requires a defined reset sequence. After power-on reset or CMD0 (software reset) the card enters an idle state. When idle, the only host commands the card will accept are CMD1 (SEND_OP_COND), ACMD41 (SD_SEND_OP_COND) and CMD58 (READ_OCR).

In SPI mode CMD1 and ACMD41 have the same function. The host must poll the card (by repeatedly sending CMD1 or ACMD41) until the 'in-idle-state' bit in the card response switches to Low, thus indicating that the card has completed its initialization process and is ready for the next command.

In the SPI mode, as opposed to the SD mode, CMD1 (and ACMD41) has no operands and does not return the contents of the OCR register. Instead, the host may use CMD58 (available in SPI mode only) to read the OCR register.

Also it is up to the host to pay attention not to gain access to cards that do not support its voltage range. The use of CMD58 is not restricted to the initializing phase, it can be issued at any time.

7.2.8 Memory Array Partitioning.

It is the same as in the SD mode.

7.2.9 Card Lock/Unlock Commands.

In the SPI mode, the Lock and Unlock commands are the same as in the SD mode.

7.2.10 Application Specific Commands.

The only difference between the SD and SPI modes is the APP_CMD status bit, which is not available in the SPI mode.

7.3 SPI Mode Commands

All the SPI commands are 6 Bytes long. The command always starts with the MSB of the string, which corresponds to the command code. See [Table 26](#) for details of the command format.

Like in the SD mode, the commands in the SPI mode are divided into classes. However, the classes supported by the two modes are different. See [Table 27](#) For details.

The commands supported in the SPI mode are described in detail in [Table 27](#) If no argument is required in the command, the value of the field should be set to '0'. Reserved commands are reserved in both the MultiMediaCard and SPI modes. The contents of the

command index field are binary: for example, it is '000000' for CMD0 and '100111' for CMD39.

For more details about commands and arguments, please refer to the SD Memory Card Specification.

Table 26. Command Format

| | | | | | | |
|---------------------|-----------|------------------|---------------|----------|-------|---------|
| Bit Position | 47 | 46 | [45:40] | [39:8] | [7:1] | 0 |
| Width (bits) | 1 | 1 | 6 | 32 | 7 | 1 |
| Value | 0 | 1 | x | x | x | 1 |
| Descriptions | Start Bit | Transmission Bit | Command Index | Argument | CRC7 | End Bit |

Table 27. Command Classes in SPI Mode

| Card CMD Class (CCC) | Class Description | Supported Commands | | | | | | | | | | | | | | | | | | | | | | | |
|----------------------|-----------------------------|--------------------|---|---|----|----|----|----|----|----|----|----|----|----|----|----|----|----|----|----|----|----|----|----|---|
| | | 0 | 1 | 9 | 10 | 12 | 13 | 16 | 17 | 18 | 24 | 25 | 27 | 28 | 29 | 30 | 32 | 33 | 38 | 42 | 55 | 56 | 58 | 59 | |
| Class 0 | Basic | + | + | + | + | + | + | | | | | | | | | | | | | | | | | + | + |
| Class 1 | Not supported in SPI | | | | | | | | | | | | | | | | | | | | | | | | |
| Class 2 | Block Read | | | | | | | + | + | + | | | | | | | | | | | | | | | |
| Class 3 | Not supported in SPI | | | | | | | | | | | | | | | | | | | | | | | | |
| Class 4 | Block Write | | | | | | | | | | + | + | + | | | | | | | | | | | | |
| Class 5 | Erase | | | | | | | | | | | | | | | | + | + | + | | | | | | |
| Class 6 | Write Protection (optional) | | | | | | | | | | | | | | | | + | + | + | | | | | | |
| Class 7 | Lock Card (optional) | | | | | | | | | | | | | | | | | | | + | | | | | |
| Class 8 | Application specific | | | | | | | | | | | | | | | | | | | | + | + | | | |
| Class 9 | Not supported in SPI | | | | | | | | | | | | | | | | | | | | | | | | |
| Class 10 - Class 11 | Reserved | | | | | | | | | | | | | | | | | | | | | | | | |

7.4 Responses

There are several types of response tokens. As in the SD mode, all are transmitted MSB first.

7.4.1 R1 Format

The card sends this response token after every command except for the SEND_STATUS command.

R1 Format Responses are one Byte long. The MSB is always zero and the other bits indicate errors, an error being indicated by a '1'.

7.4.2 R1b Format

This response token is similar to the R1 Format response token but for the option of adding the busy signal.

The busy signal token can be any number of Bytes. A zero value indicates that the card is busy. A non-zero value indicates that the card is ready for the next command.

7.4.3 R2 Format

This response token is two Bytes long. It is sent as a response to the SEND_STATUS command.

7.4.4 R3 Format

This response token is sent by the card when a READ_OCR command is received. The response length is 5 Bytes. The structure of the first Byte is identical to that of the R1 Format response. The other four Bytes contain the OCR register.

For more details about responses, please refer to the SD Memory Card Specification v.1.01.

7.5 Clearing Status Bits

In the SPI mode, as described in the previous paragraphs, status bits are reported to the host in three different formats: R1 Format response, R2 Format response and data error token (the same bits may exist in several response types - e.g. Card ECC failed).

As in the SD mode, error bits are cleared when read by the host, regardless of the response format.

State indicators are cleared either when read by the host or in accordance with the card state. For more details, please refer to the SD Memory Card Specification.

7.6 SPI Bus Timings

[Figure 38](#) illustrates the basic Command/Response transaction in SPI mode (that is, when the card is ready).

[Figure 39](#) describes a Command/ Response transaction when the card is busy (R1b response format). For timings, refer to [Table 25](#).

Table 28. SPI Timing Symbols

| | |
|---|--------------------------------------|
| S | Start Bit (=0) |
| T | Transmitter Bit (Host = 1, Card = 0) |
| P | One-Cycle Pull-up (=1) |
| E | End Bit (= 1) |
| Z | High impedance stage |
| D | Data Bits |
| * | Repeater |

Table 29. SPI Timing Values

| Timing | Min | Max | Unit |
|-----------------|-----|---------------------------|----------------|
| N _{CS} | 0 | | 8 clock cycles |
| N _{CR} | 1 | 8 | 8 clock cycles |
| N _{CX} | 0 | 8 | 8 clock cycles |
| N _{RC} | 1 | | 8 clock cycles |
| N _{AC} | 1 | Specified in CSD Register | 8 clock cycles |
| N _{WR} | 1 | | 8 clock cycles |
| N _{EC} | 0 | | 8 clock cycles |
| N _{DS} | 0 | | 8 clock cycles |
| N _{BR} | 1 | 1 | 8 clock cycles |

Figure 37. Host Command to Card Response - Card is Ready

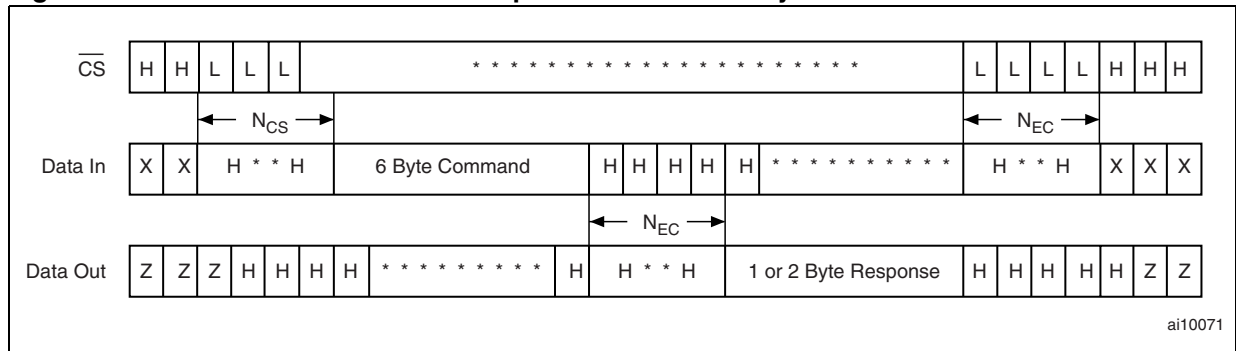

Figure 38. Host Command to Card Response - Card is Busy

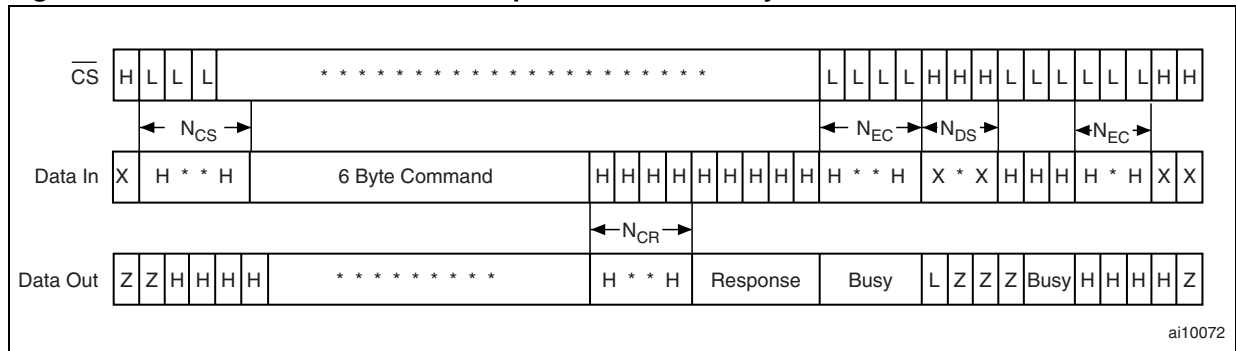
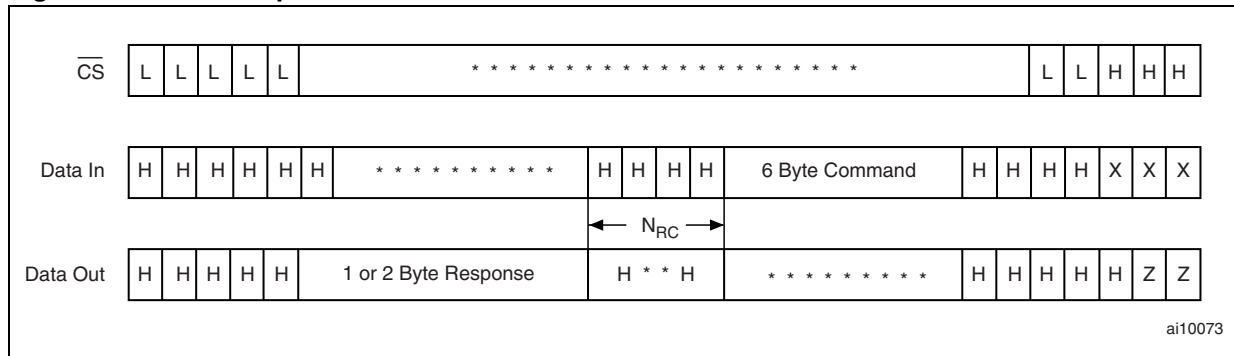

Figure 39. Card Response to Host Command



7.6.1 Data Read Timings

The timing diagram for deselecting the card by de-asserting \overline{CS} after the last card response corresponds to a standard command-to-response timing diagram as illustrated in [Figure 39](#). During open-ended Multiple Block Read operations, the STOP_TRANSMISSION command may be sent while the card is transmitting data to the host. In this case, the card stops transmitting the data block within two clock cycles (the bits in the first Byte may not all be set to '1') and returns the response message after a time measured in numbers of clock cycles (N_{CR}). See [Figure 40.](#), for details. For timings, refer to [Table 25](#).

Figure 40. Single Block Read Operation

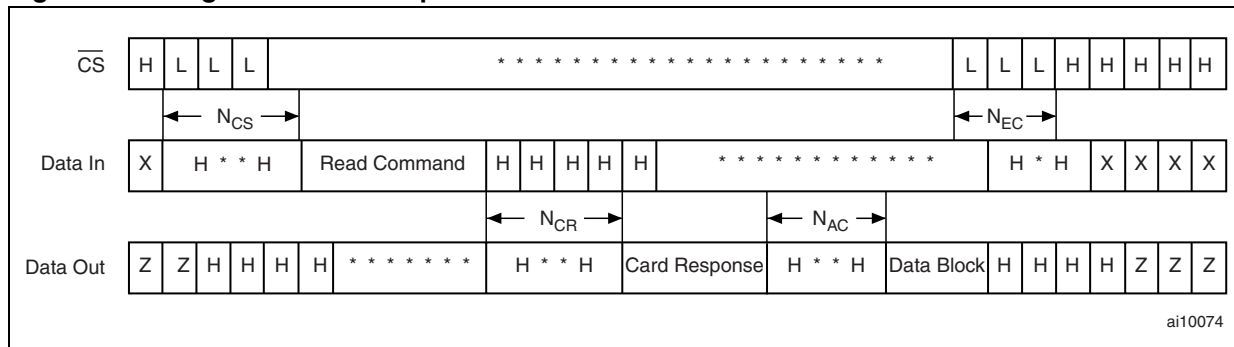

Figure 41. STOP_TRANSMISSION between Blocks During Multiple Block Read

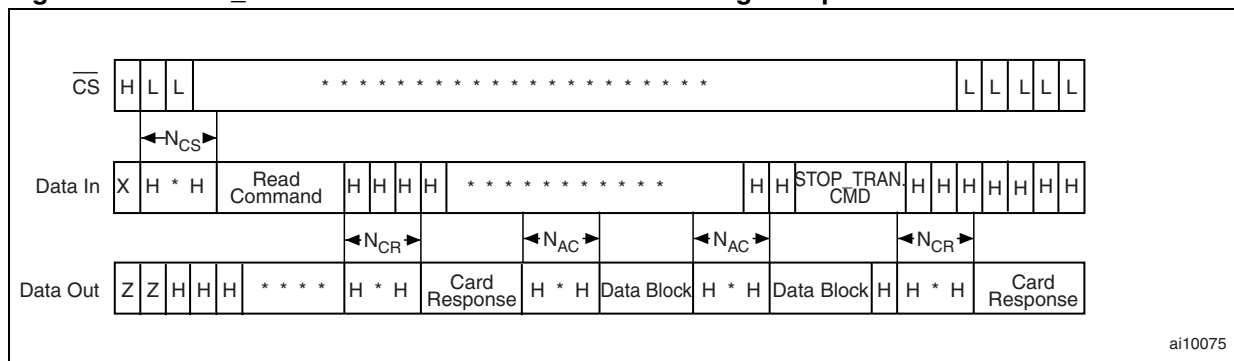
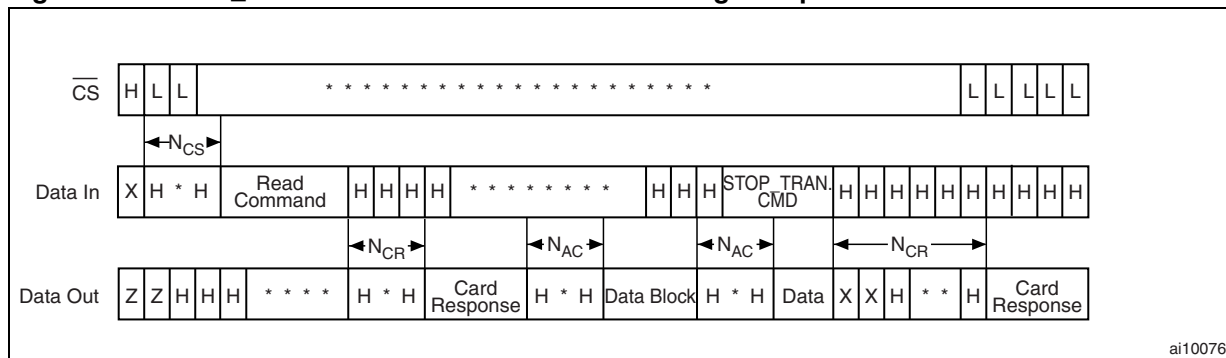
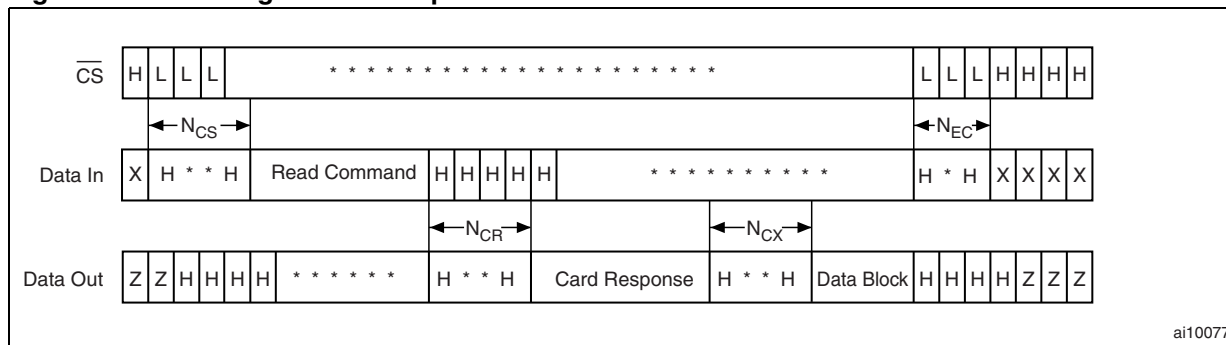

Figure 42. STOP_TRANSMISSION within a Block During Multiple Block Read



ai10076

Figure 43. CSD Register Read Operation



ai10077

7.6.2 Data Write Timings

The host may deselect a card at any moment during Single and Multiple Block Write operations. The card will release the DataOut line one clock cycle after it is deselected (\overline{CS} High). To check whether the card is still busy, the host must reselect it by driving \overline{CS} Low. The card will then take control of the DataOut line one clock cycle after being reselected. In Multiple Block Write operations, the timings from the command being issued to the first data block being transmitted by the card are the same as for Single Block Write operations (see [Figure 44](#) for details). The timing of Stop Tran prefixes is the same as that of data blocks. After the card receives the STOP_TRANSMISSION command, the data on the DataOut line is undefined for one Byte (N_{BR}), then a busy message may be sent by the card. For timings, refer to [Table 25](#).

Figure 44. Single Block Write Operation

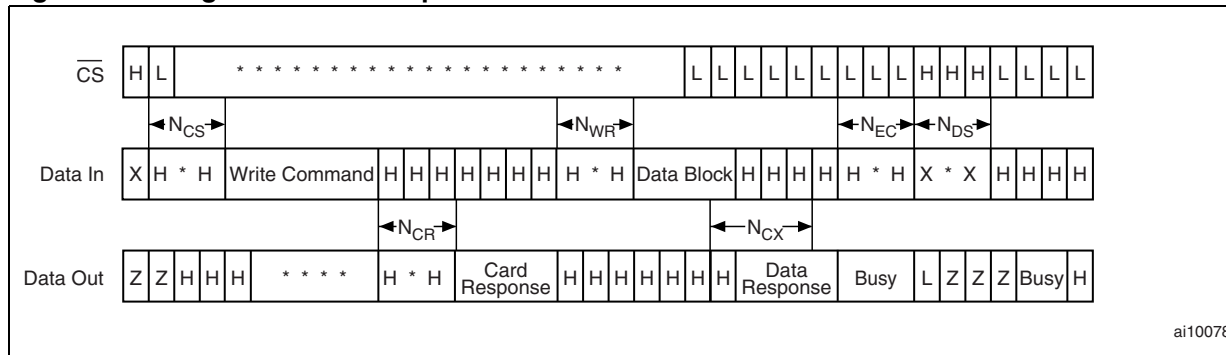

ai10078

Figure 45. Multiple Block Write Operation

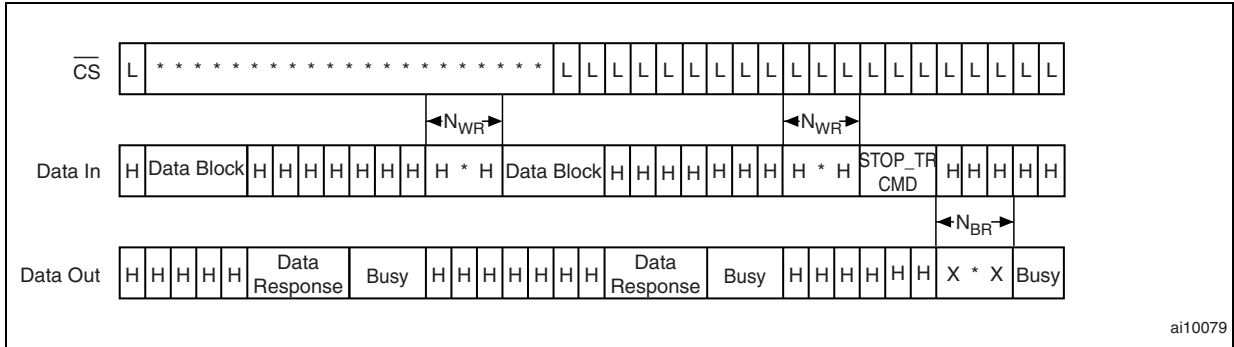

8 Package mechanical data

Figure 46. Full-Size Secure Digital Memory Card Dimensions

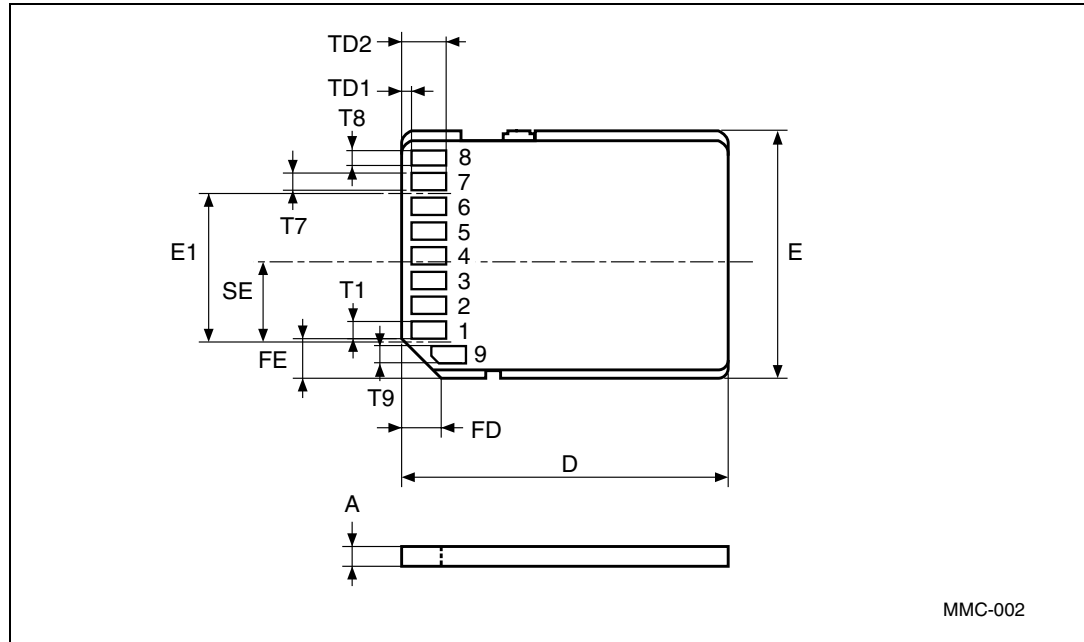

1. Drawing is not to scale.

Table 30. Full-Size Secure Digital Memory Card Mechanical Data

| Symbol | millimeters | | | inches | | |
|--------|-------------|--------|--------|--------|---------|---------|
| | Typ | Min | Max | Typ | Min | Max |
| A | 2.100 | 2.050 | 2.250 | 0.0827 | 0.0807 | 0.0886 |
| D | 32.000 | 31.900 | 32.100 | 1.2598 | 1.2559 | 1.2638 |
| E | 24.000 | 23.900 | 24.100 | 0.9449 | 0.9409 | 0.9488 |
| E1 | 15.000 | – | – | 0.5906 | – | – |
| FD | 4.000 | 3.900 | 4.100 | 0.1575 | 0.1535 | 0.1614 |
| FE | 4.000 | 3.900 | 4.100 | 0.1575 | 0.1535 | 0.1614 |
| SE | 8.125 | – | – | 0.3198 | – | – |
| T1 | – | 1.400 | – | – | 0.0551 | – |
| T9 | – | 1.400 | – | – | 0.0551 | – |
| T8 | – | 0.900 | – | – | 0.0353 | – |
| T7 | – | 1.100 | – | – | 0.04331 | – |
| TD1 | – | – | 1.600 | – | – | 0.06299 |
| TD2 | – | 5.000 | – | – | 0.19685 | – |

Figure 47. mini Secure Digital Card Dimensions

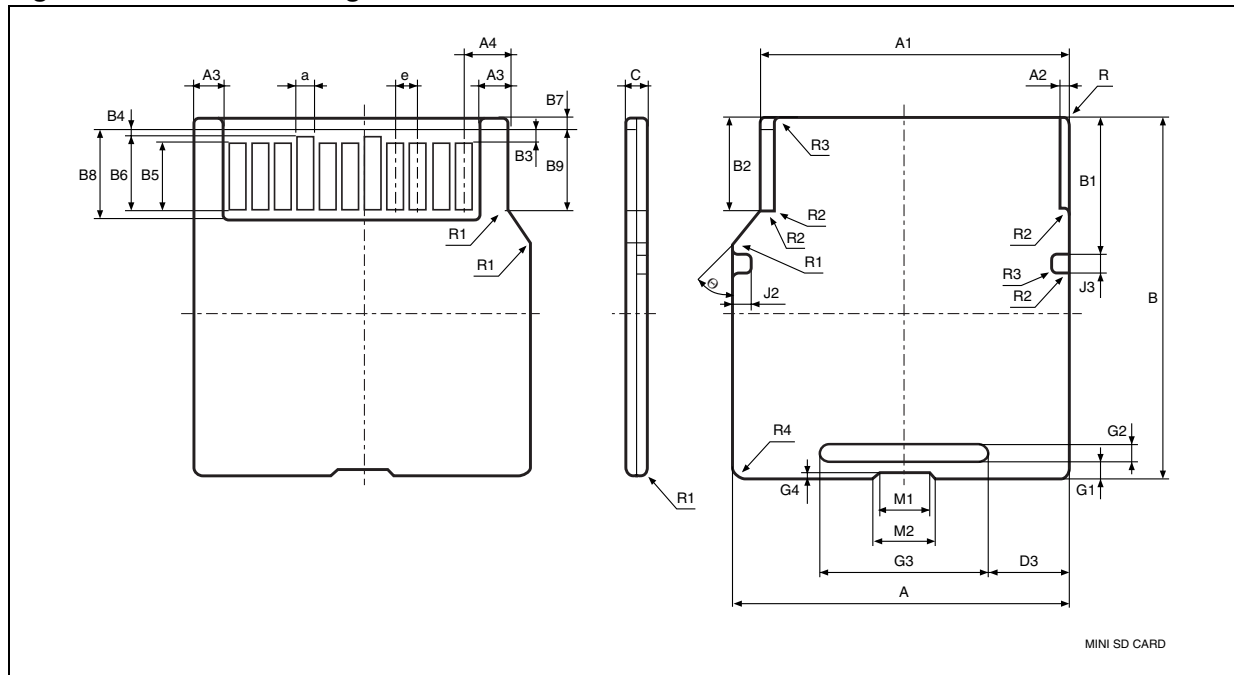

Table 31. MiniSD package mechanical data

| Symbol | millimeters | | | inches | | | Note |
|--------|-------------|-------|-------|--------|--------|--------|------|
| | Typ | Min | Max | Typ | Min | Max | |
| A | 20 | 19.90 | 20.10 | 0.7874 | 0.7834 | 0.7913 | |
| A1 | 18.50 | 18.35 | 18.65 | 0.7283 | 0.7244 | 0.7322 | |
| A2 | 0.60 | 0.50 | 0.70 | 0.0236 | 0.0216 | 0.0255 | |
| A3 | - | 1.45 | 2.05 | 0.0748 | 0.0708 | 0.0767 | |
| A4 | 2.75 | - | - | 0.1082 | 0.1062 | 0.1102 | |
| a | 1.00 | 0.85 | 1.15 | 0.0393 | 0.0374 | 0.0413 | |
| B | 21.50 | 21.40 | 21.60 | 0.8464 | 0.8425 | 0.8503 | |
| B1 | 7.70 | 7.60 | 7.80 | 0.3031 | 0.3011 | 0.3051 | |
| B2 | 5.50 | 5.40 | 5.60 | 0.2165 | 0.2145 | 0.2185 | |
| B3 | 0.50 | - | - | 0.0196 | 0.0177 | 0.0216 | |
| B4 | 0.20 | - | - | 0.0078 | - | - | |
| B5 | 3.8 | - | - | 0.1496 | 0.1476 | 0.1515 | |
| B6 | 4.10 | - | - | 0.1614 | 0.1594 | 0.1633 | |
| B7 | 1.00 | - | - | 0.0393 | 0.0374 | 0.0413 | |
| B8 | 5.00 | - | - | 0.1968 | 0.2342 | 0.1988 | |
| B9 | 4.50 | - | - | 0.1771 | 0.1751 | 0.1791 | |
| C | 1.4 | 1.3 | 1.5 | 0.0551 | 0.0511 | 0.0590 | |

Table 31. MiniSD package mechanical data (continued)

| Symbol | millimeters | | | inches | | | Note |
|--------|-------------|------|------|--------|--------|--------|--------|
| | Typ | Min | Max | Typ | Min | Max | |
| D3 | - | - | - | 0.1929 | 0.1909 | 0.1948 | |
| e | 1.30 | | | 0.0511 | 0.0492 | 0.0531 | |
| G1 | 0.60 | - | - | 0.0236 | 0.0216 | 0.0255 | |
| G2 | - | 0.60 | - | 0.0255 | 0.0236 | 0.0275 | |
| G3 | - | 10 | - | 0.4015 | 0.3976 | 0.4055 | |
| G4 | - | - | - | 0.0078 | - | - | |
| J2 | 1 | 0.90 | 1.10 | 0.0393 | 0.0374 | 0.0413 | |
| J3 | 1.20 | 1.00 | 1.40 | 0.0472 | 0.0452 | 0.0492 | |
| M1 | 3.00 | - | - | 0.1181 | 0.1161 | 0.1200 | |
| M2 | 3.60 | - | - | 0.1417 | 0.1397 | 0.1437 | |
| R | 0.50 | - | - | 0.0196 | - | - | Radius |
| R1 | 0.30 | - | - | 0.0118 | - | - | Radius |
| R2 | 0.10 | - | - | 0.0039 | - | - | Radius |
| R3 | 0.20 | - | - | 0.0078 | - | - | Radius |
| R4 | 1.00 | - | - | 0.0393 | - | - | Radius |
| θ | 45 | - | - | 45 | - | - | |

Figure 48. MicroSD card mechanical dimensions

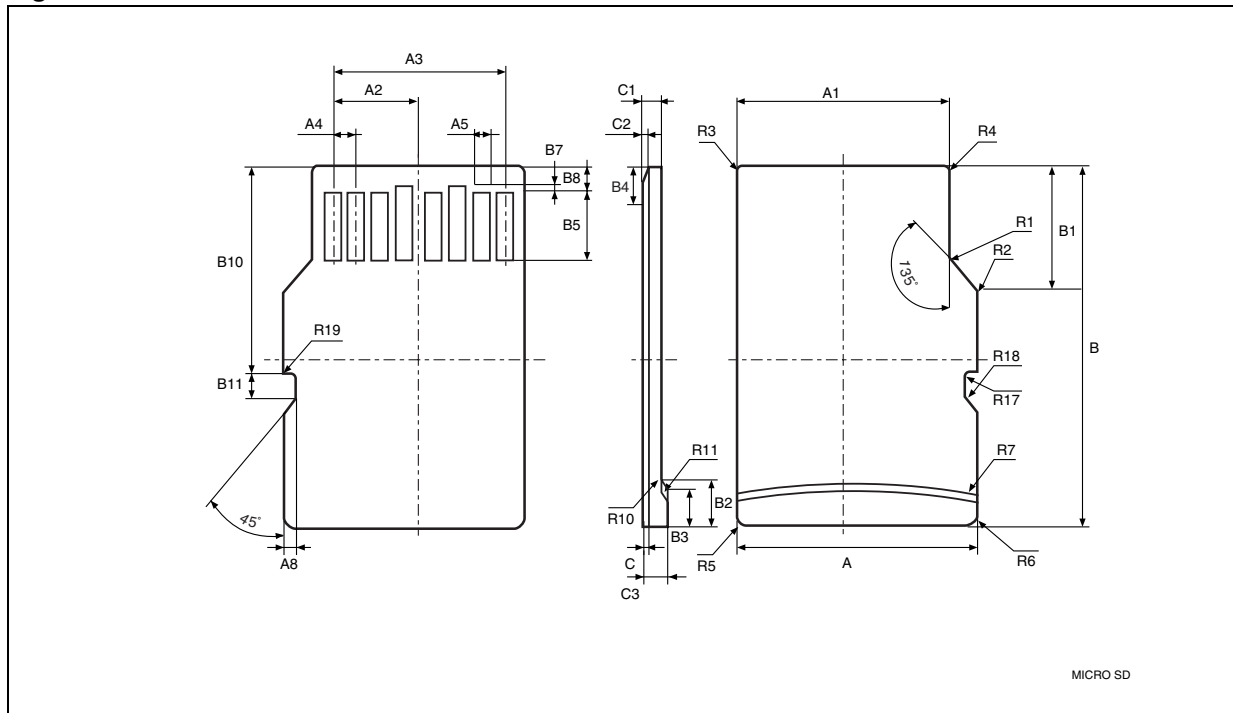

Table 32. MicroSD package mechanical data

| Symbol | millimeters | | | inches | | |
|--------|-------------|-------|-------|--------|-------|-------|
| | Min | Typ | Max | Min | Typ | Max |
| A | 10.90 | 11.00 | 11.10 | 0.429 | 0.433 | 0.437 |
| A1 | 9.60 | 9.70 | 9.80 | 0.378 | 0.382 | 0.386 |
| A2 | – | 3.85 | – | – | 0.152 | – |
| A3 | 7.60 | 7.70 | 7.80 | 0.299 | 0.303 | 0.307 |
| A4 | – | 1.10 | – | – | 0.043 | – |
| A5 | 0.75 | 0.80 | 0.85 | 0.030 | 0.031 | 0.033 |
| A8 | 0.60 | 0.70 | 0.80 | 0.024 | 0.028 | 0.031 |
| B | 14.90 | 15.00 | 15.10 | 0.587 | 0.591 | 0.594 |
| B1 | 6.30 | 6.40 | 6.50 | 0.248 | 0.252 | 0.256 |
| B2 | 1.64 | 1.84 | 2.04 | 0.065 | 0.072 | 0.080 |
| B3 | 1.30 | 1.50 | 1.70 | 0.051 | 0.059 | 0.067 |
| B4 | 0.42 | 0.52 | 0.62 | 0.017 | 0.020 | 0.024 |
| B5 | 2.80 | 2.90 | 3.00 | 0.110 | 0.114 | 0.118 |
| B7 | 0.20 | 0.30 | 0.40 | 0.008 | 0.012 | 0.016 |
| B8 | 1.00 | 1.10 | 1.20 | 0.039 | 0.043 | 0.047 |
| B10 | 7.80 | 7.90 | 8.00 | 0.307 | 0.311 | 0.315 |
| B11 | 1.10 | 1.20 | 1.30 | 0.043 | 0.047 | 0.051 |

Table 32. MicroSD package mechanical data (continued)

| Symbol | millimeters | | | inches | | |
|--------|-------------|-------|-------|--------|-------|-------|
| | Min | Typ | Max | Min | Typ | Max |
| c | 0.17 | 0.21 | 0.25 | 0.007 | 0.008 | 0.010 |
| C1 | 0.60 | 0.70 | 0.80 | 0.024 | 0.028 | 0.031 |
| C2 | 0.20 | 0.30 | 0.40 | 0.008 | 0.012 | 0.016 |
| C3 | 0.90 | 1.00 | 1.10 | 0.035 | 0.039 | 0.043 |
| R1 | 0.20 | 0.40 | 0.60 | 0.008 | 0.016 | 0.024 |
| R2 | 0.20 | 0.40 | 0.60 | 0.008 | 0.016 | 0.024 |
| R3 | 0.70 | 0.80 | 0.90 | 0.028 | 0.031 | 0.035 |
| R4 | 0.70 | 0.80 | 0.90 | 0.028 | 0.031 | 0.035 |
| R5 | 0.70 | 0.80 | 0.90 | 0.028 | 0.031 | 0.035 |
| R6 | 0.70 | 0.80 | 0.90 | 0.028 | 0.031 | 0.035 |
| R7 | 29.50 | 30.00 | 30.50 | 1.161 | 1.181 | 1.201 |
| R10 | - | 0.20 | - | - | 0.008 | - |
| R11 | - | 0.20 | - | - | 0.008 | - |
| R17 | 0.10 | 0.20 | 0.30 | 0.004 | 0.008 | 0.012 |
| R18 | 0.20 | 0.40 | 0.60 | 0.008 | 0.016 | 0.024 |
| R19 | 0.05 | - | 0.20 | 0.002 | - | 0.008 |

9 Part numbering

Table 33. Ordering Information Scheme

| Example: | SMS | 256 | A | F | A | 5 | E |
|--|-----|-----|---|---|---|---|---|
| Memory Card Standard | | | | | | | |
| SMS = Storage Medium, Secure Digital | | | | | | | |
| Density | | | | | | | |
| 064 = 64 MBytes | | | | | | | |
| 128 = 128 MBytes | | | | | | | |
| 256 = 256 MBytes | | | | | | | |
| 512 = 512 MBytes | | | | | | | |
| 01G = 1GByte | | | | | | | |
| Options of the Standard | | | | | | | |
| A = SD full size | | | | | | | |
| B = MiniSD (reduced size) | | | | | | | |
| F = MicroSD | | | | | | | |
| Memory Type | | | | | | | |
| F = Flash Memory | | | | | | | |
| Card Version | | | | | | | |
| A = Version depending on device mix. | | | | | | | |
| Temperature Range | | | | | | | |
| 5 = -25 to 85°C | | | | | | | |
| Packing | | | | | | | |
| E = ECOPACK package, standard packing (tray) | | | | | | | |

Note: Other digits may be added to the ordering code for preprogrammed parts or other options. Devices are shipped from the factory with the memory content bits erased to '1'. For further information on any aspect of the device, please contact the nearest Numonyx Sales Office.

Appendix A Power supply decoupling

The V_{SS1} , V_{SS2} and V_{DD} lines supply the card with the operating voltage. To do this, decoupling capacitors for buffering current peak are used. These capacitors are placed on the bus side corresponding to [Figure 49](#).

Figure 49. Power supply decoupling

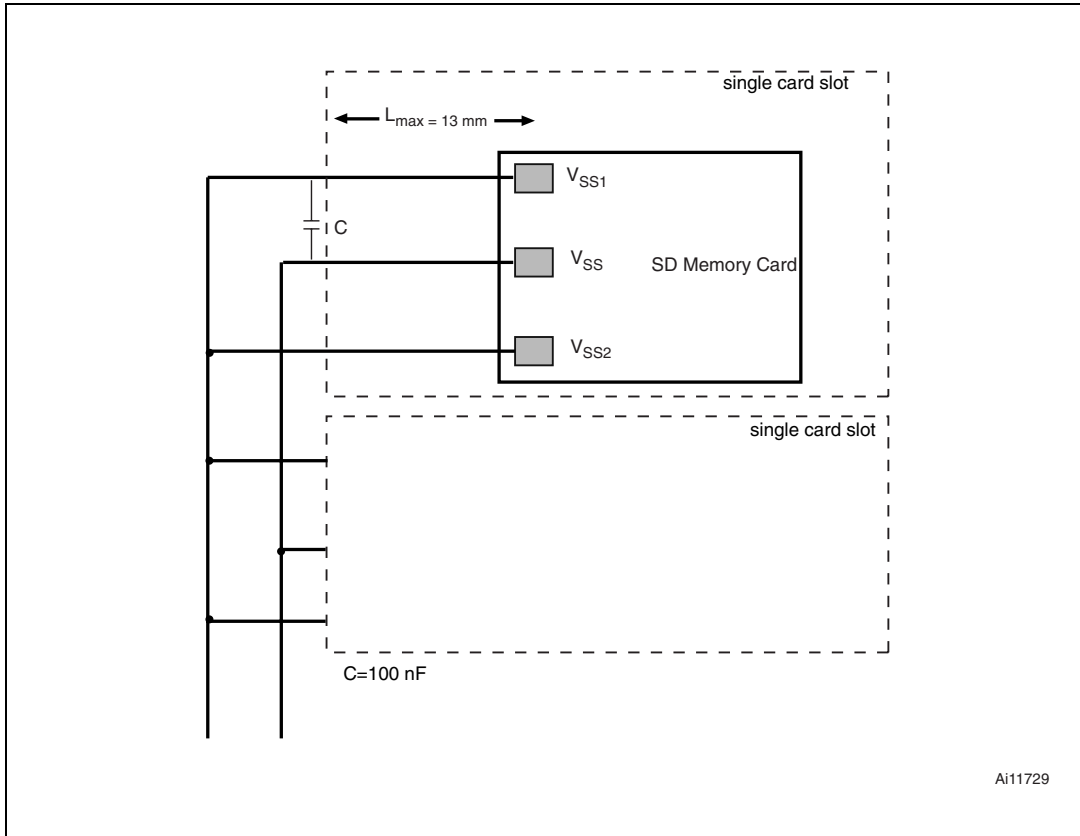

The host controller includes a central buffer capacitor for V_{DD} . Its value is $1 \mu\text{F/slot}$.

10 Revision history

Table 34. Document Revision History

| Date | Rev. | Description of Revision |
|-------------|------|--|
| 28-Jul-2006 | 1 | First issue. |
| 15-Dec-2006 | 2 | Added SD, miniSD and MicroSD available in Halogen free and Antimony free packages. Information on power dissipation removed from <i>Features</i> section. V_{DD} updated in <i>Note 1</i> below <i>Table 3: Power consumption</i> . <i>Figure 10: Data Packet format</i> and <i>Figure 11: SD Memory Card State Diagram (Card Identification Mode)</i> updated. |
| 10-Dec-2007 | 3 | Applied Numonyx branding. |

Please Read Carefully:

INFORMATION IN THIS DOCUMENT IS PROVIDED IN CONNECTION WITH NUMONYX™ PRODUCTS. NO LICENSE, EXPRESS OR IMPLIED, BY ESTOPPEL OR OTHERWISE, TO ANY INTELLECTUAL PROPERTY RIGHTS IS GRANTED BY THIS DOCUMENT. EXCEPT AS PROVIDED IN NUMONYX'S TERMS AND CONDITIONS OF SALE FOR SUCH PRODUCTS, NUMONYX ASSUMES NO LIABILITY WHATSOEVER, AND NUMONYX DISCLAIMS ANY EXPRESS OR IMPLIED WARRANTY, RELATING TO SALE AND/OR USE OF NUMONYX PRODUCTS INCLUDING LIABILITY OR WARRANTIES RELATING TO FITNESS FOR A PARTICULAR PURPOSE, MERCHANTABILITY, OR INFRINGEMENT OF ANY PATENT, COPYRIGHT OR OTHER INTELLECTUAL PROPERTY RIGHT.

Numonyx products are not intended for use in medical, life saving, life sustaining, critical control or safety systems, or in nuclear facility applications.

Numonyx may make changes to specifications and product descriptions at any time, without notice.

Numonyx, B.V. may have patents or pending patent applications, trademarks, copyrights, or other intellectual property rights that relate to the presented subject matter. The furnishing of documents and other materials and information does not provide any license, express or implied, by estoppel or otherwise, to any such patents, trademarks, copyrights, or other intellectual property rights.

Designers must not rely on the absence or characteristics of any features or instructions marked "reserved" or "undefined." Numonyx reserves these for future definition and shall have no responsibility whatsoever for conflicts or incompatibilities arising from future changes to them.

Contact your local Numonyx sales office or your distributor to obtain the latest specifications and before placing your product order.

Copies of documents which have an order number and are referenced in this document, or other Numonyx literature may be obtained by visiting Numonyx's website at <http://www.numonyx.com>.

Numonyx StrataFlash is a trademark or registered trademark of Numonyx or its subsidiaries in the United States and other countries.

*Other names and brands may be claimed as the property of others.

Copyright © 11/5/7, Numonyx, B.V., All Rights Reserved.