

ASSP

Spread Spectrum Clock Generator

MB88151A

■ DESCRIPTION

MB88151A is a clock generator for EMI (Electro Magnetic Interference) reduction. The peak of unnecessary radiation noise (EMI) can be attenuated by making the oscillation frequency slightly modulate periodically with the internal modulator. It corresponds to both of the center spread which modulates frequency in modulation off as Middle Centered and down spread which modulates so as not to exceed frequency in modulation off.

■ FEATURES

	MB88151A-100/101 (multiply-by-1)	MB88151A-200/201 (multiply-by-2)	MB88151A-400/401 (multiply-by-4)	MB88151A-500/501 (multiply-by-1/2)	MB88151A-800/801 (multiply-by-8)
Input frequency/ Output frequency	16.6 MHz to 33.4 MHz/ 16.6 MHz to 33.4 MHz	16.6 MHz to 33.4 MHz/ 33.2 MHz to 66.8 MHz	16.6 MHz to 33.4 MHz/ 66.4 MHz to 133.6 MHz	16.6 MHz to 33.4 MHz/ 8.3 MHz to 16.7 MHz	8.3 MHz to 16.7 MHz 66.4 MHz to 133.6 MHz
Modulation clock cycle-cycle jitter	Less than 100 ps	Less than 100 ps	Less than 150 ps	Less than 200 ps	Less than 150 ps

- Modulation rate : $\pm 0.5\%$, $\pm 1.5\%$ (Center spread), $- 1.0\%$, $- 3.0\%$ (Down spread)
- Equipped with oscillation circuit : Range of oscillation 8.3 MHz to 33.4 MHz
- Modulation clock output Duty : 40% to 60%
- Low current consumption by CMOS process : 5 mA (24 MHz : Typ-sample, no load)
- Power supply voltage : $3.3 \text{ V} \pm 0.3 \text{ V}$
- Operating temperature : $- 40 \text{ }^\circ\text{C}$ to $+ 85 \text{ }^\circ\text{C}$
- Package : SOP 8-pin

MB88151A

■ PRODUCT LINEUP

MB88151A has five kinds of multiplication type.

Product	Input frequency range	Multiplier ratio	Output frequency range
MB88151A-100/101	16.6 MHz to 33.4 MHz	Multiply-by-1	16.6 MHz to 33.4 MHz
MB88151A-200/201		Multiply-by-2	33.2 MHz to 66.8 MHz
MB88151A-400/401		Multiply-by-4	66.4 MHz to 133.6 MHz
MB88151A-500/501		Multiply-by-1/2	8.3 MHz to 16.7 MHz
MB88151A-800/801	8.3 MHz to 16.7 MHz	Multiply-by-8	66.4 MHz to 133.6 MHz

■ PIN ASSIGNMENT

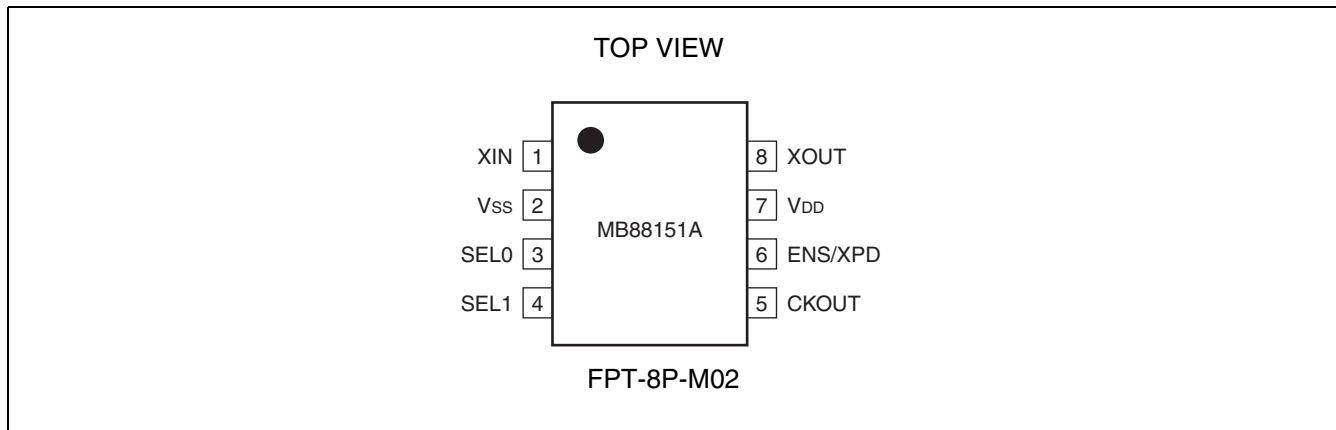

■ PIN DESCRIPTION

Pin name	I/O	Pin no.	Description
XIN	I	1	Resonator connection pin/clock input pin
V _{SS}	—	2	GND pin
SEL0	I	3	Modulation rate setting pin
SEL1	I	4	Modulation rate setting pin
CKOUT	O	5	Modulated clock output pin
ENS/XPD	I	6	Modulation enable setting pin (with pull-up resistance)/ Power down pin (with pull-up resistor)*
V _{DD}	—	7	Power supply voltage pin
XOUT	O	8	Resonator connection pin

* : XPD = 800 kΩ pull-up resistor at “L”

■ I/O CIRCUIT TYPE

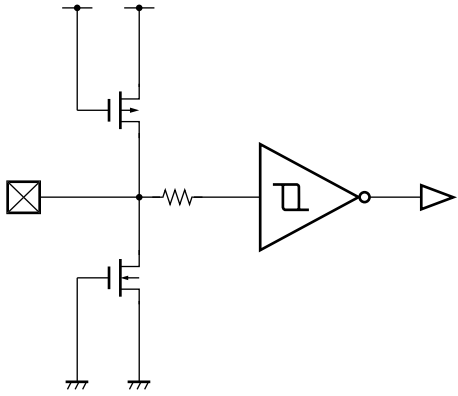
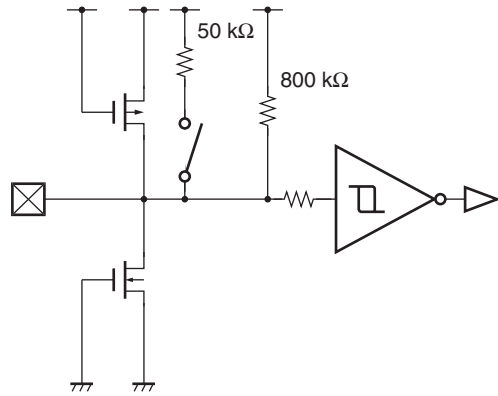
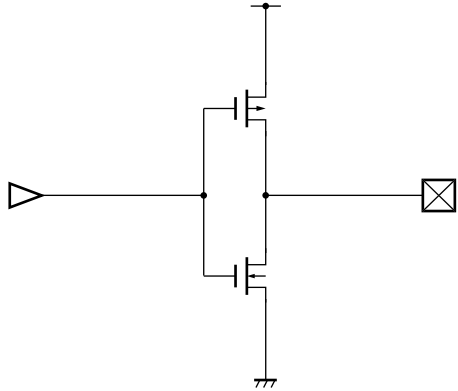
Pin	Circuit type	Remarks
SEL0, SEL1		CMOS hysteresis input
ENS		CMOS hysteresis input with 50 kΩ + 800 kΩ (Typ) pull-up resistors Note : If "L" is input to XPD when the XPD function is selected, 50 kΩ pull-up resistor is disconnected.
CKOUT		<ul style="list-style-type: none"> • CMOS output • $I_{OL} = 4 \text{ mA}$

Note : For XIN and XOUT pins, refer to "■ OSCILLATION CIRCUIT".

■ HANDLING DEVICES

Preventing Latch-up

A latch-up can occur if, on this device, (a) a voltage higher than V_{DD} or a voltage lower than V_{SS} is applied to an input or output pin or (b) a voltage higher than the rating is applied between V_{DD} pin and V_{SS} pin. The latch-up, if it occurs, significantly increases the power supply current and may cause thermal destruction of an element. When you use this device, be very careful not to exceed the maximum rating.

Handling unused pins

Do not leave an unused input pin open, since it may cause a malfunction. Handle by, using a pull-up or pull-down resistor.

Unused output pin should be opened.

The attention when the external clock is used

Input the clock to XIN pin, and XOUT pin should be opened when you use the external clock. Please pay attention so that an overshoot and an undershoot do not occur to an input clock of XIN pin.

Power supply pins

Please design connecting the power supply pin of this device by as low impedance as possible from the current supply source.

We recommend connecting electrolytic capacitor (about 10 μF) and the ceramic capacitor (about 0.01 μF) in parallel between V_{SS} pin and V_{DD} pin near the device, as a bypass capacitor.

Oscillation circuit

Noise near the XIN and XOUT pins may cause the device to malfunction. Design printed circuit boards so that electric wiring of XIN or XOUT pin and the resonator do not intersect other wiring.

Design the printed circuit board that surrounds the XIN and XOUT pins with ground.

■ BLOCK DIAGRAM

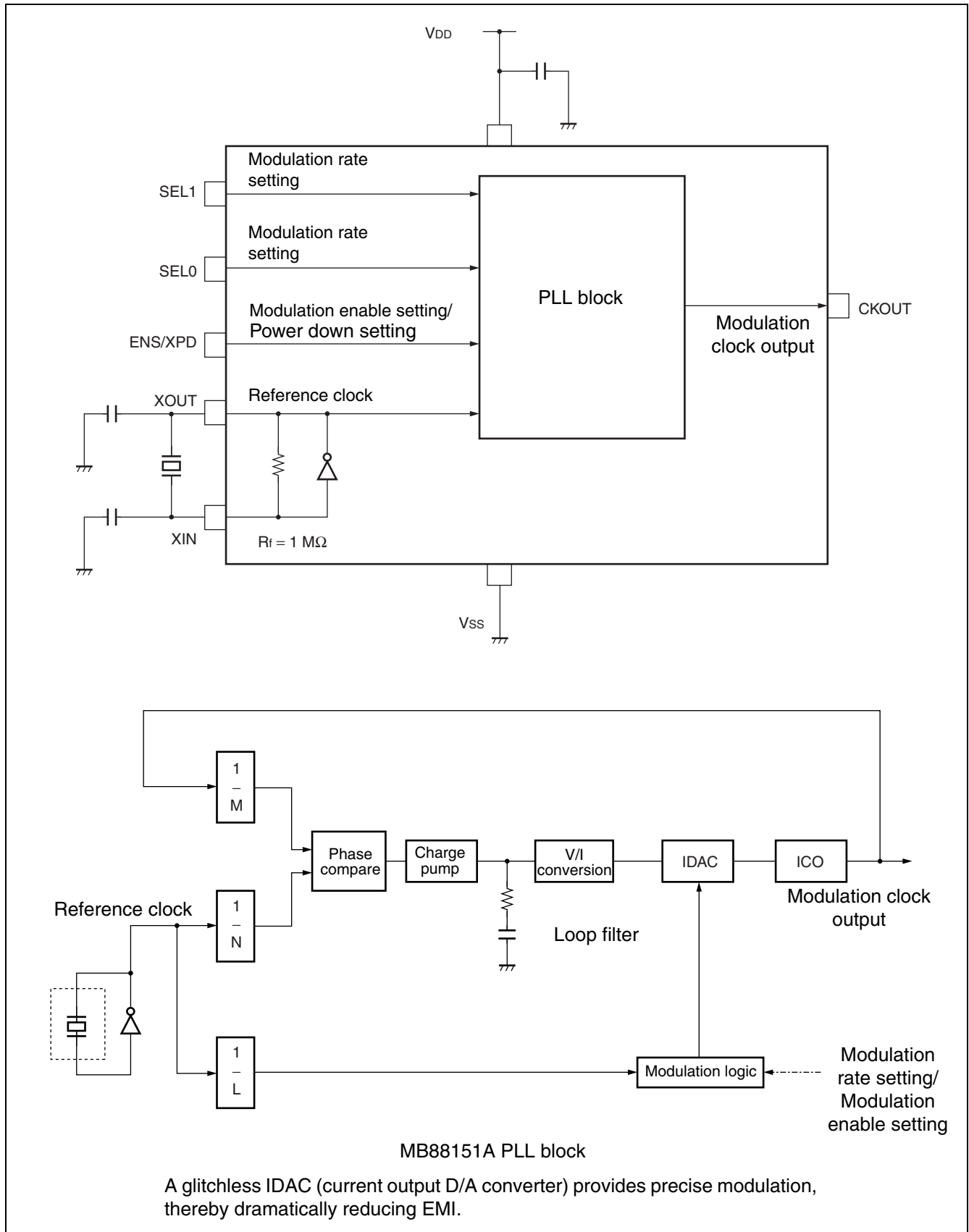

MB88151A

■ PIN SETTING

When changing the pin setting, the stabilization wait time for the modulation clock is required. The stabilization wait time for the modulation clock take the maximum value of “■ ELECTRICAL CHARACTERISTICS • AC Characteristics Lock-up time”.

ENS modulation enable setting (MB88151A-100/200/400/500/800)

ENS	Modulation
L	No modulation
H	Modulation

Note : Spectrum does not spread when “L” is set to ENS. The clock with low jitter can be obtained. Because of ENS has Pull-up resistance, spectrum spread when “H” is set to it or open the terminal.

XPD Power down setting (MB88151A-101/201/401/501/801)

XPD	Status
L	Power down Status
H	Operating status

Note : CKOUT of output pins are fixed to “L” output during power down.

SEL0, SEL1 Modulation rate setting

SEL1	SEL0	Modulation rate	Modulation type
L	L	± 1.5%	Center spread
L	H	± 0.5%	Center spread
H	L	– 1.0%	Down spread
H	H	– 3.0%	Down spread

Note : The modulation rate can be changed at the level of the terminal.

- Center spread

Spectrum is spread (modulated) by centering on the frequency in modulation off.

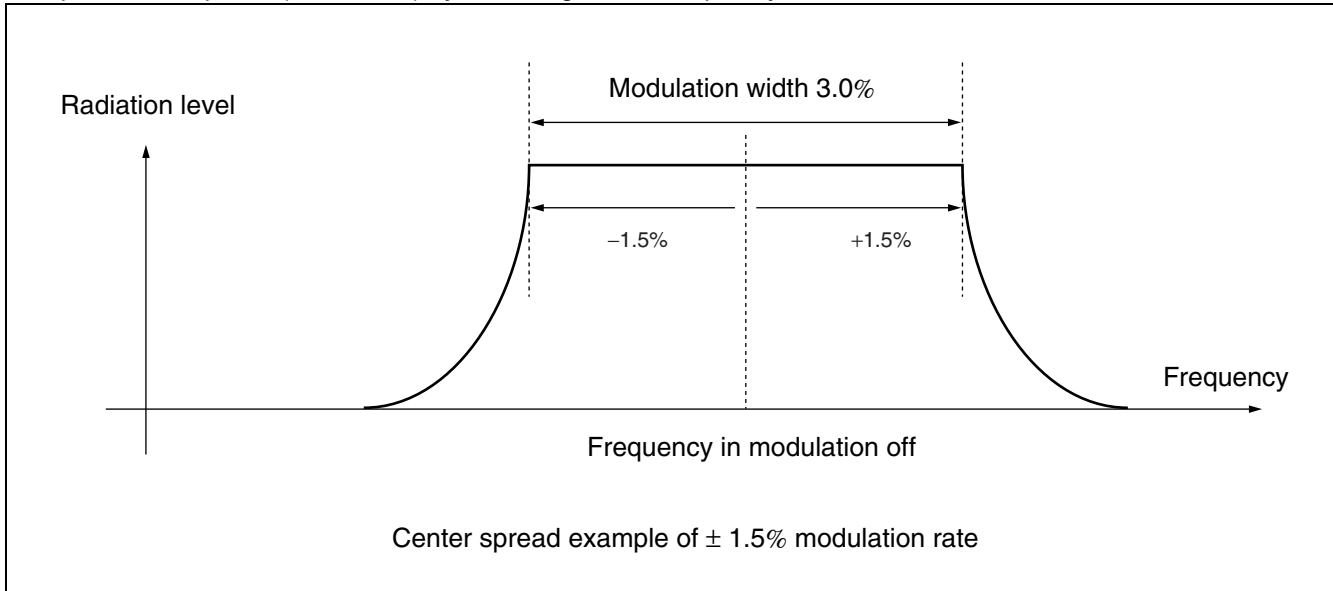

- Down spread

Spectrum is spread (modulated) below the frequency in modulation off.

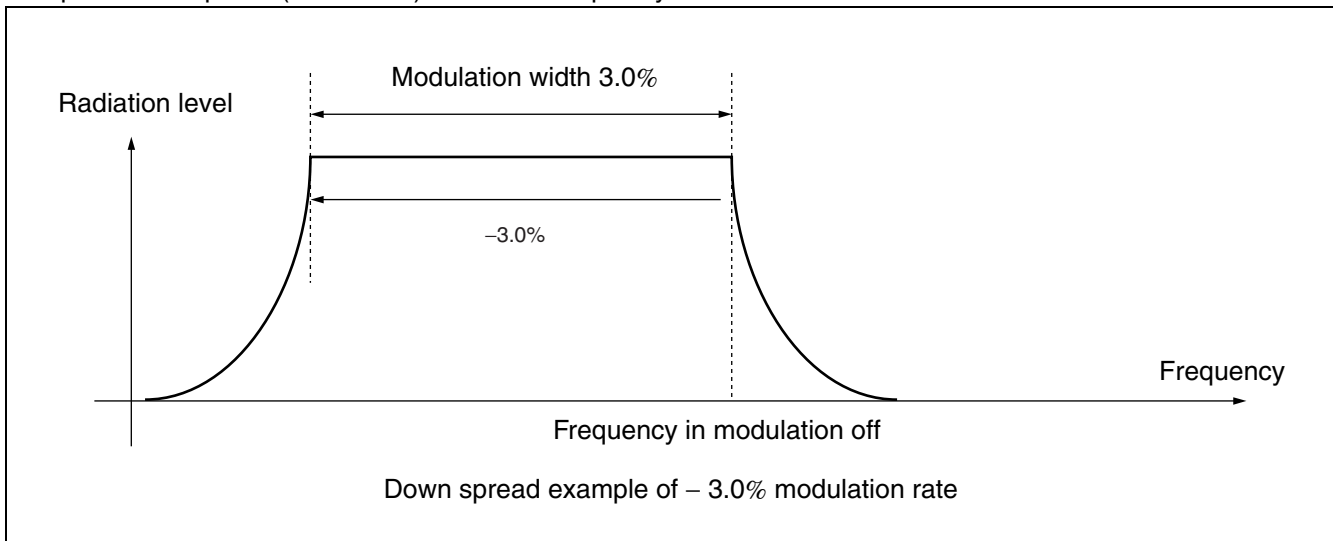

MB88151A

■ ABSOLUTE MAXIMUM RATINGS

Parameter	Symbol	Rating		Unit
		Min	Max	
Power supply voltage*	V_{DD}	- 0.5	+ 4.0	V
Input voltage*	V_I	$V_{SS} - 0.5$	$V_{DD} + 0.5$	V
Output voltage*	V_O	$V_{SS} - 0.5$	$V_{DD} + 0.5$	V
Storage temperature	T_{ST}	- 55	+ 125	°C
Operation junction temperature	T_J	- 40	+ 125	°C
Output current	I_O	- 14	+ 14	mA
Overshoot	V_{IOVER}	—	$V_{DD} + 1.0$ ($t_{OVER} \leq 50$ ns)	V
Undershoot	V_{IUNDER}	$V_{SS} - 1.0$ ($t_{UNDER} \leq 50$ ns)	—	V

* : The parameter is based on $V_{SS} = 0.0$ V.

WARNING: Semiconductor devices can be permanently damaged by application of stress (voltage, current, temperature, etc.) in excess of absolute maximum ratings. Do not exceed these ratings.

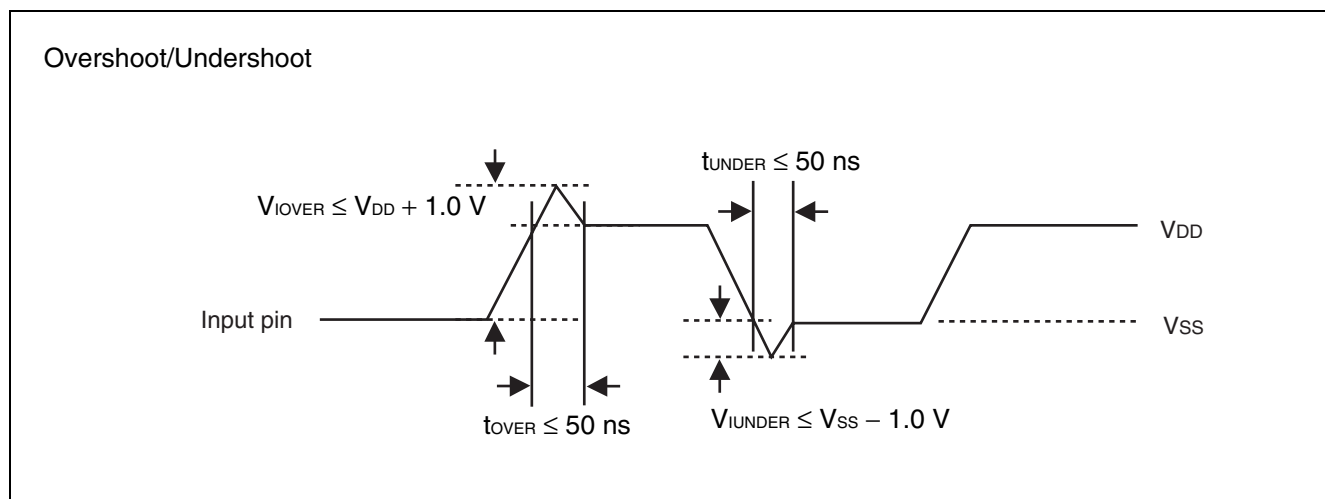

RECOMMENDED OPERATING CONDITIONS

($V_{SS} = 0.0\text{ V}$)

Parameter	Symbol	Pin	Conditions	Value			Unit
				Min	Typ	Max	
Power supply voltage	V_{DD}	V_{DD}	—	3.0	3.3	3.6	V
“H” level input voltage	V_{IH}	XIN, SEL0, SEL1, ENS	—	$V_{DD} \times 0.8$	—	$V_{DD} + 0.3$	V
“L” level input voltage	V_{IL}		—	V_{SS}	—	$V_{DD} \times 0.2$	V
Input clock duty cycle	t_{DCI}	XIN	8.3 MHz to 33.4 MHz	40	50	60	%
Operating temperature	T_a	—	—	- 40	—	+ 85	°C

WARNING: The recommended operating conditions are required in order to ensure the normal operation of the semiconductor device. All of the device’s electrical characteristics are warranted when the device is operated within these ranges.

Always use semiconductor devices within their recommended operating condition ranges. Operation outside these ranges may adversely affect reliability and could result in device failure.

No warranty is made with respect to uses, operating conditions, or combinations not represented on the data sheet. Users considering application outside the listed conditions are advised to contact their FUJITSU representatives beforehand.

Input clock duty cycle ($t_{DCI} = t_b/t_a$)

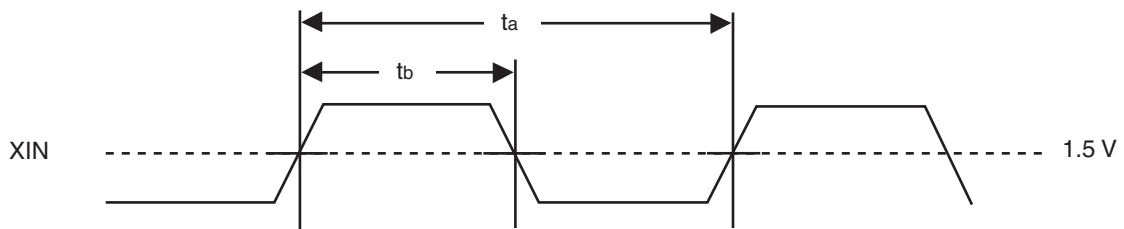

MB88151A

■ ELECTRICAL CHARACTERISTICS

- DC Characteristics

($T_a = -40\text{ }^\circ\text{C}$ to $+85\text{ }^\circ\text{C}$, $V_{DD} = 3.3\text{ V} \pm 0.3\text{ V}$, $V_{SS} = 0.0\text{ V}$)

Parameter	Symbol	Pin	Conditions	Value			Unit
				Min	Typ	Max	
Power supply current	I_{CC}	V_{DD}	No load capacitance at output 24 MHz MB88151A-100	—	5.0	7.0	mA
			At power down MB88151A-101	—	10	—	μA
Output voltage	V_{OH}	CKOUT	“H” level output, $I_{OH} = -4\text{ mA}$	$V_{DD} - 0.5$	—	V_{DD}	V
	V_{OL}		“L” level output, $I_{OL} = 4\text{ mA}$	V_{SS}	—	0.4	V
Output impedance	Z_o	CKOUT	8.3 MHz to 133.6 MHz	—	45	—	Ω
Input capacitance	C_{IN}	XIN, SEL0, SEL1, ENS	$T_a = +25\text{ }^\circ\text{C}$, $V_{DD} = V_i = 0.0\text{ V}$, $f = 1\text{ MHz}$	—	—	16	pF
Load capacitance	C_L	CKOUT	8.3 MHz to 66.8 MHz	—	—	15	pF
			66.8 MHz to 100 MHz	—	—	10	
			100 MHz to 133.6 MHz	—	—	7	
Input pull-up resistance	R_{PUE}	ENS	$V_{IL} = 0.0\text{ V}$	25	50	200	$\text{k}\Omega$
	R_{PUP}	XPD	$V_{IL} = 0.0\text{ V}$	500	800	1200	

• AC Characteristics

($T_a = -40\text{ }^\circ\text{C}$ to $+85\text{ }^\circ\text{C}$, $V_{DD} = 3.3\text{ V} \pm 0.3\text{ V}$, $V_{SS} = 0.0\text{ V}$)

Parameter	Symbol	Pin	Conditions	Value			Unit
				Min	Typ	Max	
Oscillation frequency	f_x	XIN, XOUT	Fundamental oscillation	8.3	—	33.4	MHz
Input frequency	f_{in}	XIN	External clock input (multiply-by-1, 2, 4, divided by 2)	16.6	—	33.4	MHz
			External clock input (multiply-by-8)	8.3	—	16.7	
Output frequency	f_{out}	CKOUT	MB88151A-100/101 (Multiply by 1)	16.6	—	33.4	MHz
			MB88151A-200/201 (Multiply by 2)	33.2	—	66.8	
			MB88151A-400/401 (Multiply by 4)	66.4	—	133.6	
			MB88151A-500/501 (2-frequency division)	8.3	—	16.7	
			MB88151A-800/801 (multiply-by-8)	66.4	—	133.6	
Output slew rate	SR	CKOUT	0.4 V to 2.4 V Load capacitance 15 pF	0.4	—	4.0	V/ns
Output clock duty cycle	t_{DCC}	CKOUT	1.5 V	40	—	60	%
Modulation period (Number of input clocks per modulation)	f_{MOD} (n_{MOD})	CKOUT	MB88151A-100/101, MB88151A-200/201, MB88151A-400/401, MB88151A-500/501	$f_{in}/2200$ (2200)	$f_{in}/1900$ (1900)	$f_{in}/1600$ (1600)	kHz (clks)
			MB88151A-800/801	$f_{in}/880$ (880)	$f_{in}/760$ (760)	$f_{in}/640$ (640)	kHz (clks)
Lock-up time	t_{LK}	CKOUT	8.3 MHz to 80 MHz	—	2	5	ms
			80 MHz to 133.6 MHz	—	3	8	
Cycle-cycle jitter	t_{JC}	CKOUT	MB88151A-100/101, MB88151A-200/201 No load capacitance, $T_a = +25\text{ }^\circ\text{C}$, $V_{DD} = 3.3\text{ V}$	—	—	100	ps-rms
			MB88151A-400/401, MB88151A-800/801 No load capacitance, $T_a = +25\text{ }^\circ\text{C}$, $V_{DD} = 3.3\text{ V}$	—	—	150	
			MB88151A-500/501 No load capacitance, $T_a = +25\text{ }^\circ\text{C}$, $V_{DD} = 3.3\text{ V}$	—	—	200	

Note : The modulation clock stabilization wait time is required after the power is turned on, the IC recovers from power saving, or after FREQ (frequency range) or ENS (modulation ON/OFF) setting is changed. For the modulation clock stabilization wait time, assign the maximum value for lock-up time.

<Definition of modulation frequency and number of input clocks per modulation>

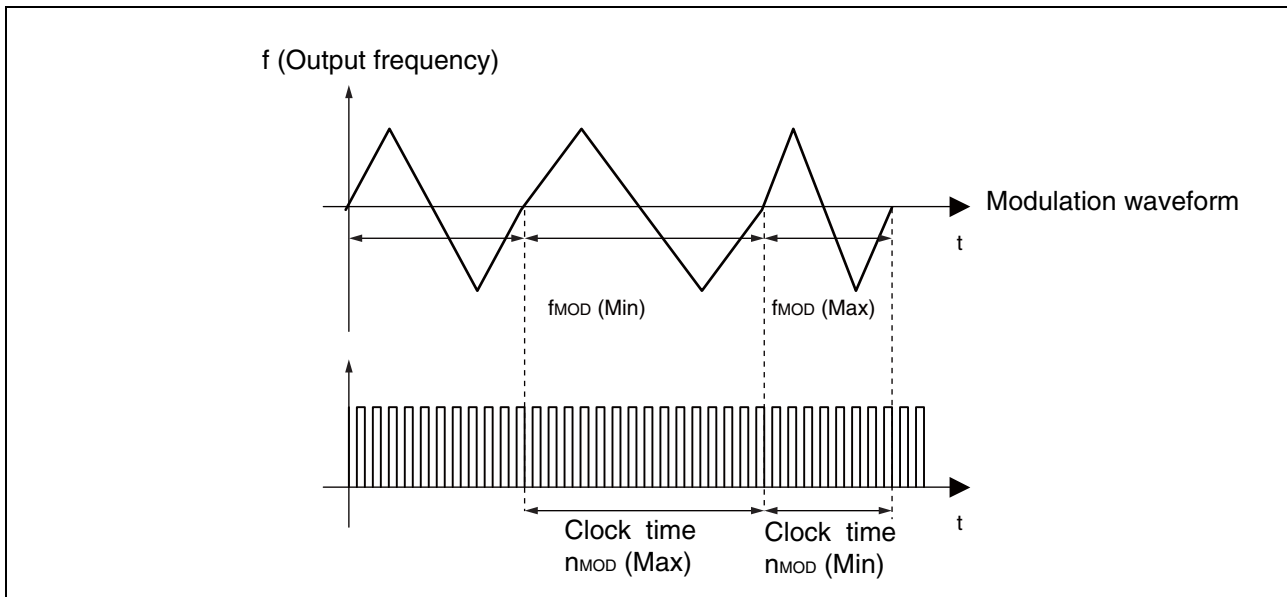

MB88151A contains the modulation period to realize the efficient EMI reduction.

The modulation period f_{MOD} depends on the input frequency and changes between $f_{MOD} (Min)$ and $f_{MOD} (Max)$.

Furthermore, the average value of f_{MOD} equals the typical value of the electrical characteristics.

■ OUTPUT CLOCK DUTY CYCLE ($t_{DCC} = t_b/t_a$)

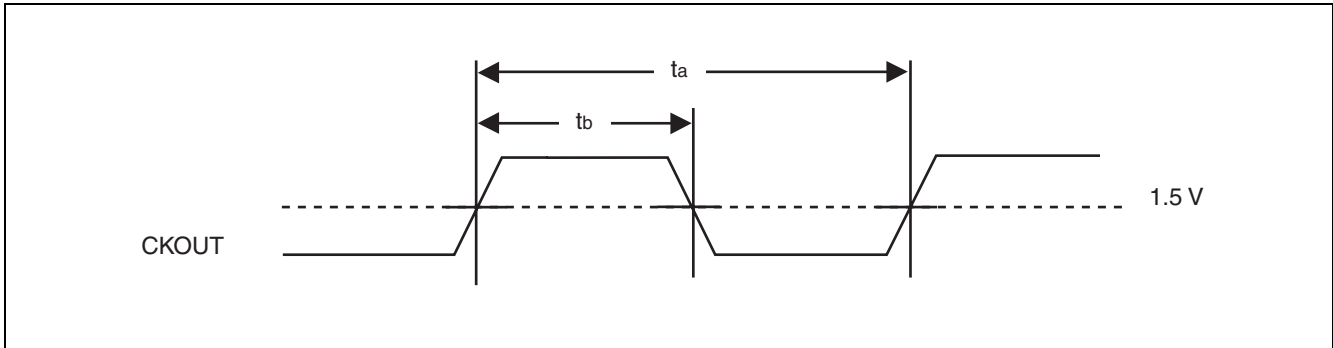

■ INPUT FREQUENCY ($f_{in} = 1/t_{in}$)

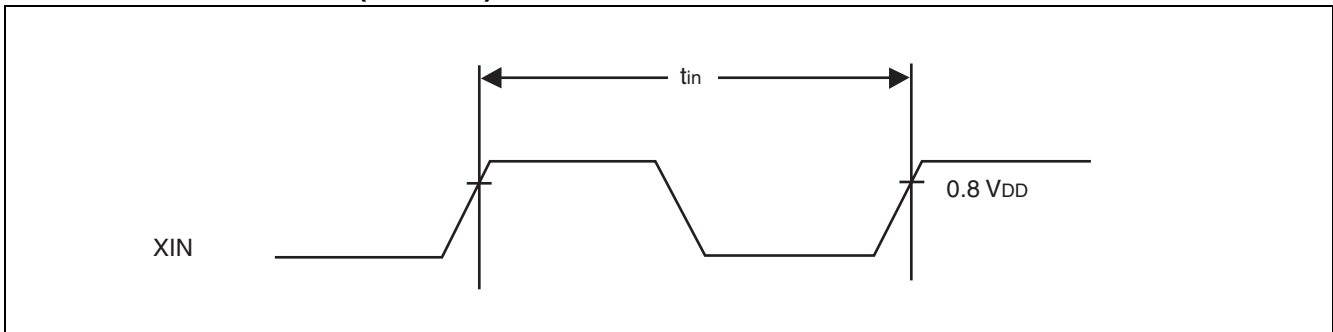

■ OUTPUT SLEW RATE (SR)

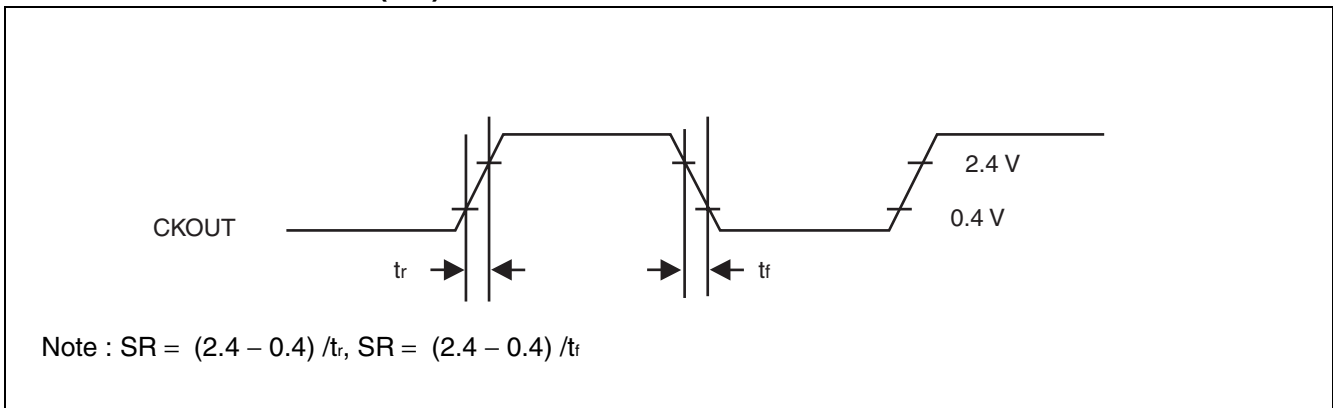

■ CYCLE-CYCLE JITTER ($t_{JC} = |t_n - t_{n+1}|$)

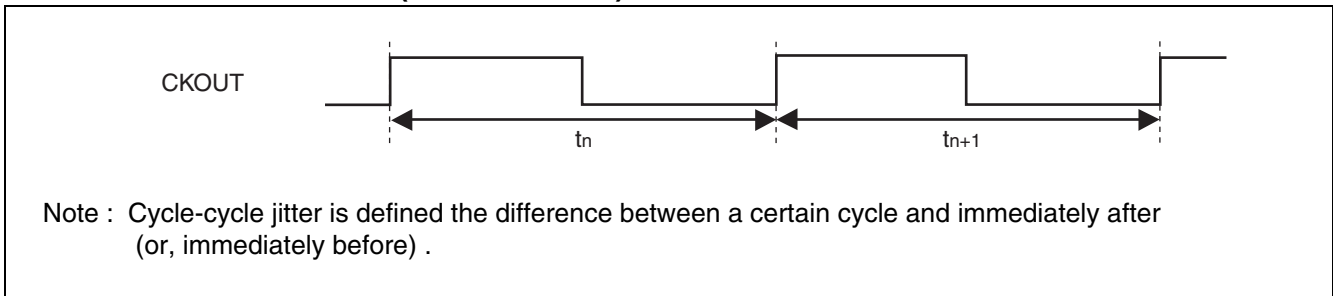

■ MODULATION WAVEFORM

- $\pm 1.5\%$ modulation rate, Example of center spread

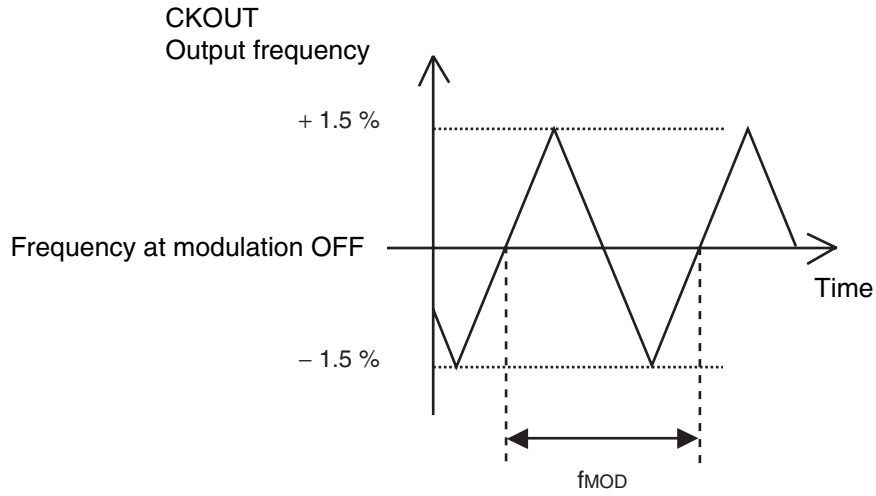

- -1.0% modulation rate, Example of down spread

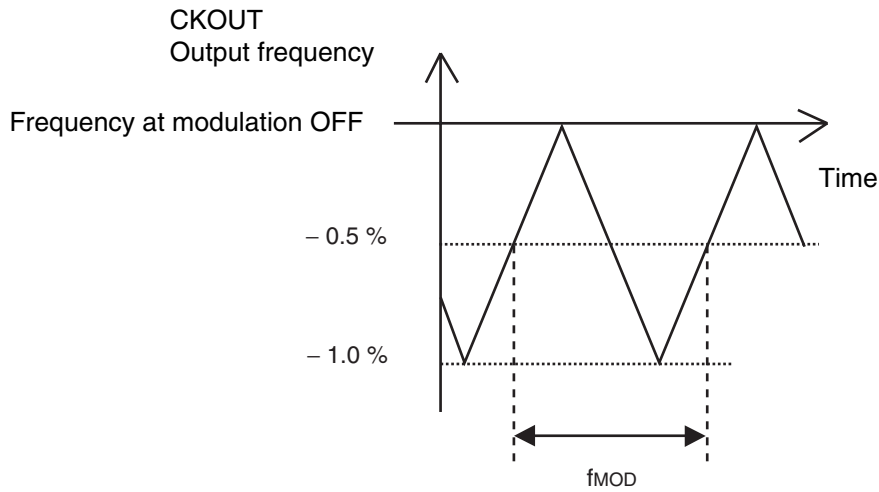

■ LOCK-UP TIME

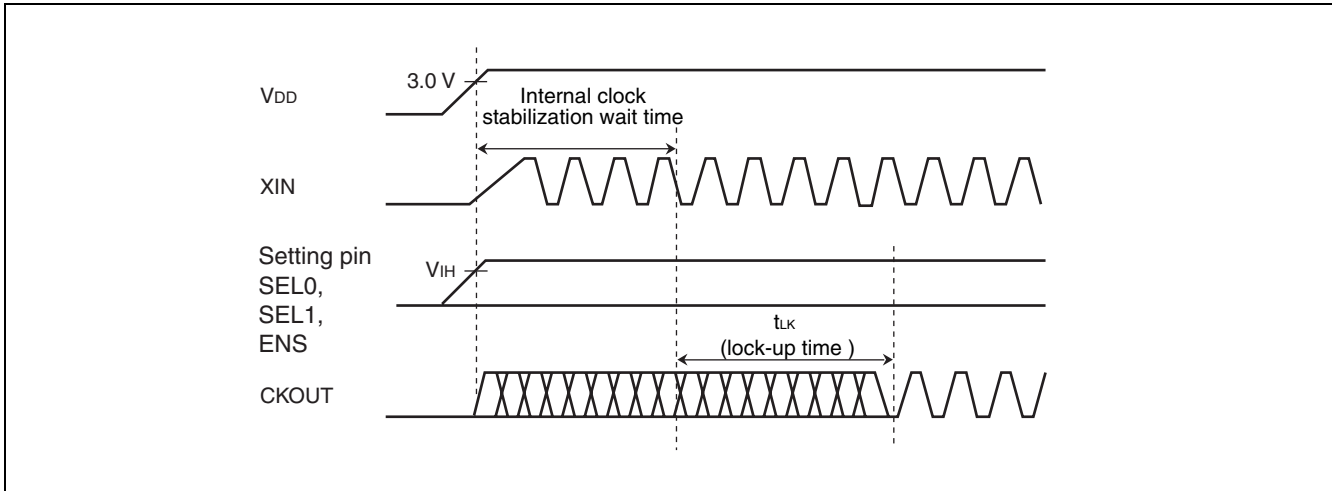

If the setting pin is fixed at the “H” or “L” level, the maximum time after the power is turned on until the set clock signal is output from CKOUT pin is (the stabilization wait time of input clock to XIN pin) + (the lock-up time “ t_{LK} ”). For the input clock stabilization time, check the characteristics of the resonator or oscillator used.

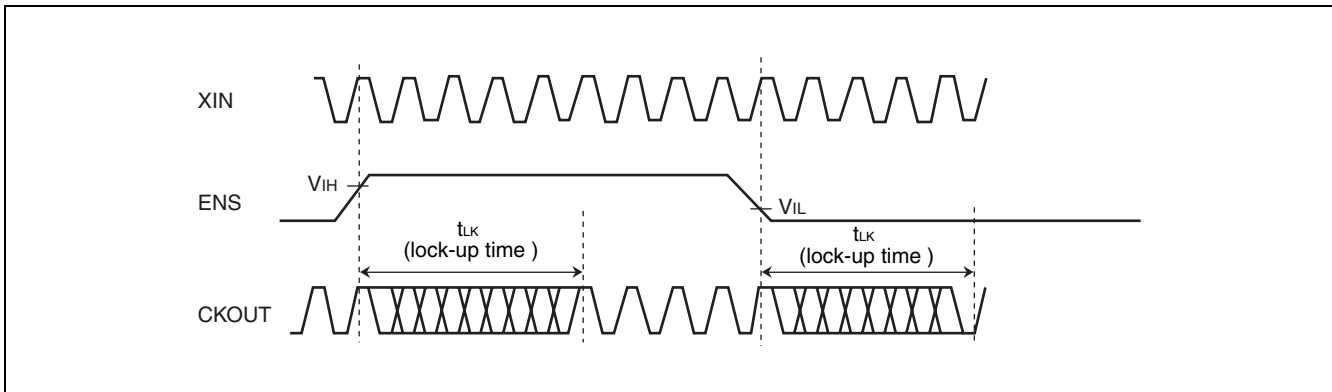

For modulation enable control using the ENS pin during normal operation, the set clock signal is output from CKOUT pin at most the lock-up time (t_{LK}) after the level at the ENS pin is determined.

Note : When the pin setting is changed, the CKOUT pin output clock stabilization time is required. Until the output clock signal becomes stable, the output frequency, output clock duty cycle, modulation period, and cycle-cycle jitter cannot be guaranteed. It is therefore advisable to perform processing such as cancelling a reset of the device at the succeeding stage after the lock-up time.

MB88151A

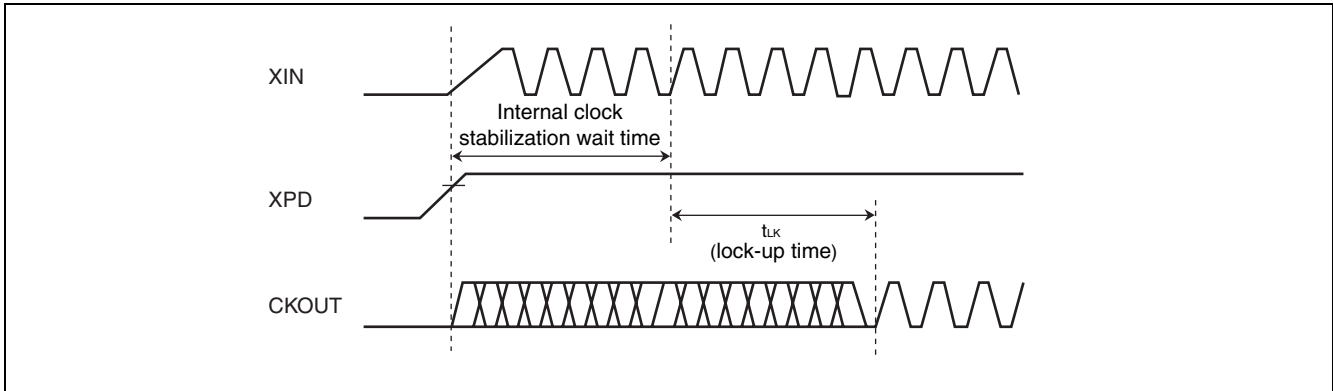

When the power down is controlled by XPD pin, the desired clock is obtained after the pin is set to H level until the maximum lock-up time t_{LK} is elapsed.

■ OSCILLATION CIRCUIT

The figure below shows the connection example about general resonator. The oscillation circuit has the built-in resistance ($1\text{ M}\Omega$). The value of capacity (C_1 and C_2) is required adjusting to the most suitable value of individual resonator.

The most suitable value is different by individual resonator. Please refer to the resonator manufacturer which you use for the most suitable value.

Input the clock to XIN pin, and do not connect anything with XOUT pin if you use the external clock (you do not use the resonator).

- When using the resonator

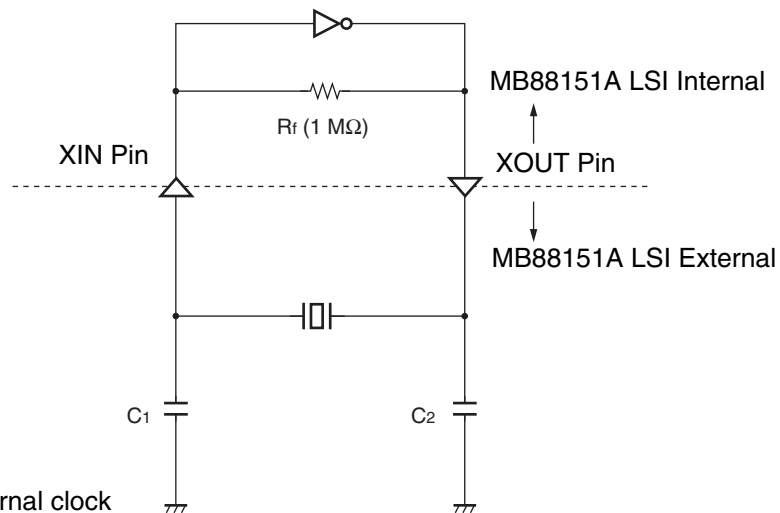

- When using an external clock

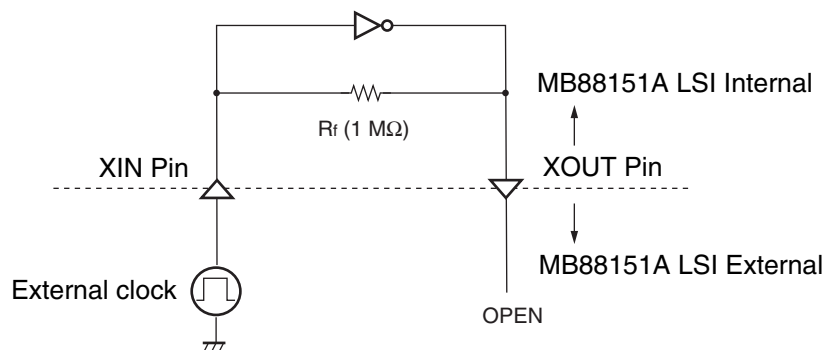

Note : Note that a jitter characteristic of an input clock may cause an affect a cycle-cycle jitter characteristic.

MB88151A

■ INTERCONNECTION CIRCUIT EXAMPLE

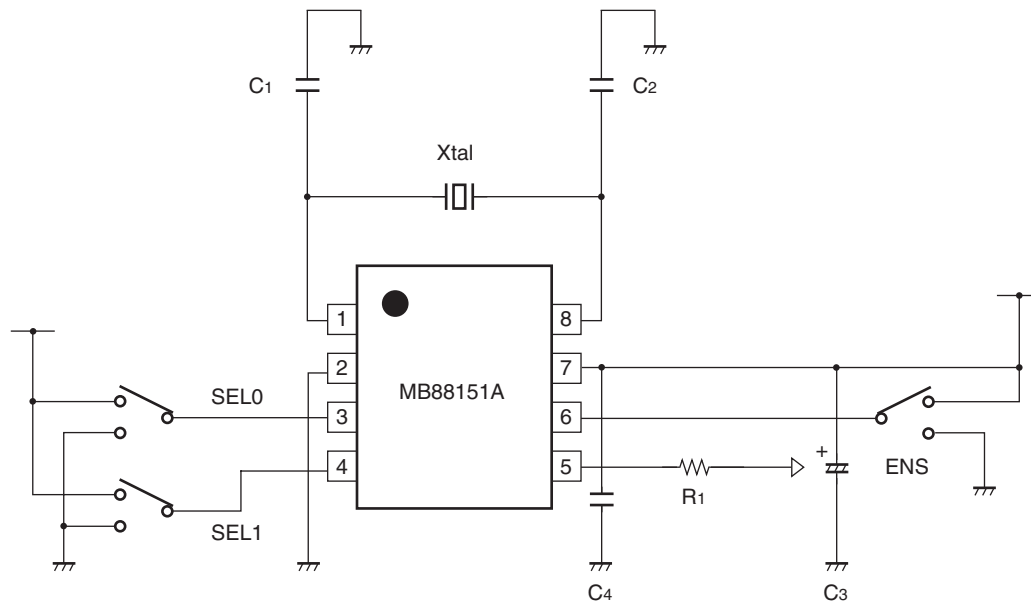

- C₁, C₂ : Oscillation stabilization capacitance (refer to "■ OSCILLATION CIRCUIT".)
- C₃ : Capacitor of 10 μ F or higher
- C₄ : Capacitor about 0.01 μ F (connect a capacitor of good high frequency property (ex. laminated ceramic capacitor) to close to this device.)
- R₁ : Impedance matching resistor for board pattern

■ SPECTRUM EXAMPLE CHARACTERISTICS

The condition of the examples of the characteristic is shown as follows : Input frequency = 20 MHz (Output frequency = 20 MHz : Using MB88151A-100 (Multiply-by-1)), Power - supply voltage = 3.3 V, None load capacity, Modulation rate = $\pm 1.5\%$ (center spread).

Spectrum analyzer HP4396B is connected with CKOUT. The result of the measurement with RBW = 1 kHz (ATT use for -6dB).

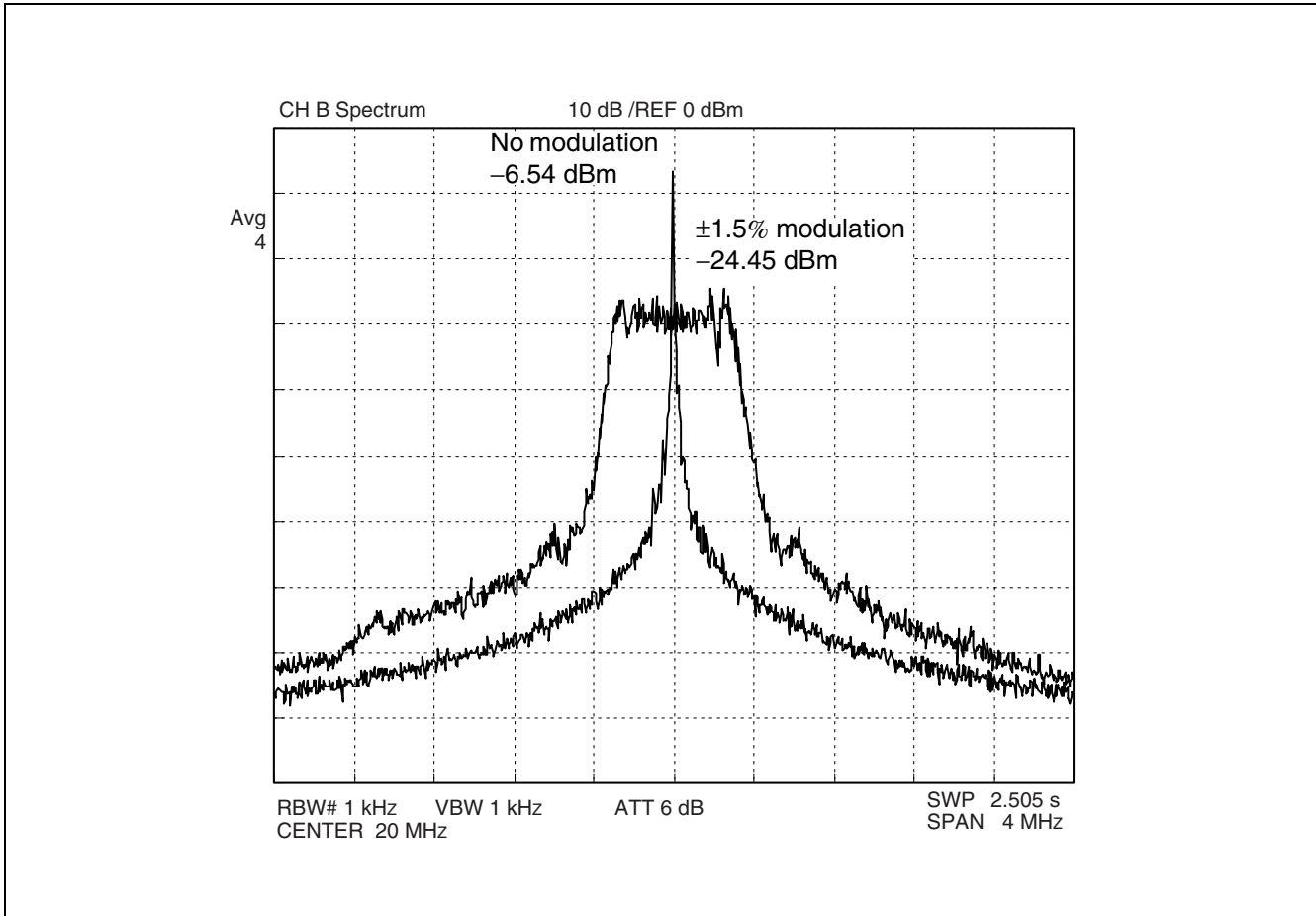

MB88151A

■ ORDERING INFORMATION

Part number	Input frequency range	Multiplier ratio	Output frequency range	Package	Remarks	
MB88151APNF-G-100-JNE1 MB88151APNF-G-101-JNE1	16.6 MHz to 33.4 MHz	Multiply-by-1	16.6 MHz to 33.4 MHz	8-pin plastic SOP (FPT-8P-M02)		
MB88151APNF-G-200-JNE1 MB88151APNF-G-201-JNE1		Multiply-by-2	33.2 MHz to 66.8 MHz			
MB88151APNF-G-400-JNE1 MB88151APNF-G-401-JNE1		Multiply-by-4	66.4 MHz to 133.6 MHz			
MB88151APNF-G-500-JNE1 MB88151APNF-G-501-JNE1		Multiply-by-1/2	8.3 MHz to 16.7 MHz			
MB88151APNF-G-800-JNE1 MB88151APNF-G-801-JNE1	8.3 MHz to 16.7 MHz	Multiply-by-8	66.4 MHz to 133.6 MHz			
MB88151APNF-G-100-JNEFE1 MB88151APNF-G-101-JNEFE1	16.6 MHz to 33.4 MHz	Multiply-by-1	16.6 MHz to 33.4 MHz			Emboss taping (EF type)
MB88151APNF-G-200-JNEFE1 MB88151APNF-G-201-JNEFE1		Multiply-by-2	33.2 MHz to 66.8 MHz			
MB88151APNF-G-400-JNEFE1 MB88151APNF-G-401-JNEFE1		Multiply-by-4	66.4 MHz to 133.6 MHz			
MB88151APNF-G-500-JNEFE1 MB88151APNF-G-501-JNEFE1		Multiply-by-1/2	8.3 MHz to 16.7 MHz			
MB88151APNF-G-800-JNEFE1 MB88151APNF-G-801-JNEFE1	8.3 MHz to 16.7 MHz	Multiply-by-8	66.4 MHz to 133.6 MHz			
MB88151APNF-G-100-JNERE1 MB88151APNF-G-101-JNERE1	16.6 MHz to 33.4 MHz	Multiply-by-1	16.6 MHz to 33.4 MHz			Emboss taping (ER type)
MB88151APNF-G-200-JNERE1 MB88151APNF-G-201-JNERE1		Multiply-by-2	33.2 MHz to 66.8 MHz			
MB88151APNF-G-400-JNERE1 MB88151APNF-G-401-JNERE1		Multiply-by-4	66.4 MHz to 133.6 MHz			
MB88151APNF-G-500-JNERE1 MB88151APNF-G-501-JNERE1		Multiply-by-1/2	8.3 MHz to 16.7 MHz			
MB88151APNF-G-800-JNERE1 MB88151APNF-G-801-JNERE1	8.3 MHz to 16.7 MHz	Multiply-by-8	66.4 MHz to 133.6 MHz			

■ PACKAGE DIMENSION

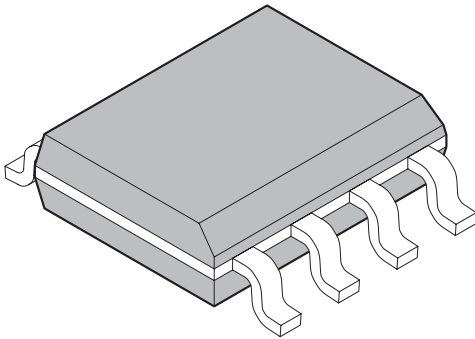
<p style="text-align: center;">8-pin plastic SOP</p>  <p style="text-align: center;">(FPT-8P-M02)</p>	Lead pitch	1.27 mm
	Package width × package length	3.9 × 5.05 mm
	Lead shape	Gullwing
	Sealing method	Plastic mold
	Mounting height	1.75 mm MAX
	Weight	0.06 g

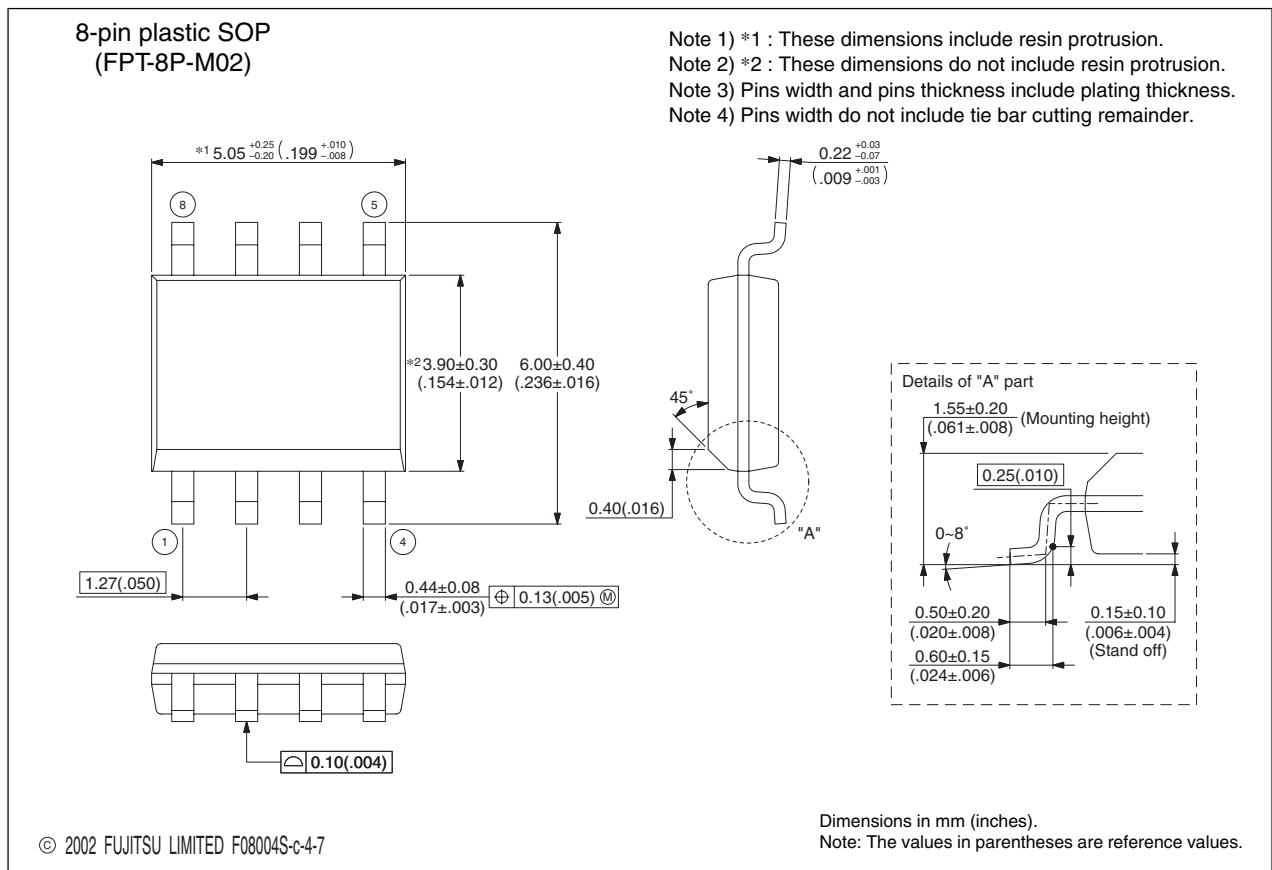

Please confirm the latest Package dimension by following URL.
<http://edevic.fujitsu.com/fj/DATASHEET/ef-ovpklv.html>

FUJITSU LIMITED

All Rights Reserved.

The contents of this document are subject to change without notice. Customers are advised to consult with FUJITSU sales representatives before ordering.

The information, such as descriptions of function and application circuit examples, in this document are presented solely for the purpose of reference to show examples of operations and uses of Fujitsu semiconductor device; Fujitsu does not warrant proper operation of the device with respect to use based on such information. When you develop equipment incorporating the device based on such information, you must assume any responsibility arising out of such use of the information. Fujitsu assumes no liability for any damages whatsoever arising out of the use of the information.

Any information in this document, including descriptions of function and schematic diagrams, shall not be construed as license of the use or exercise of any intellectual property right, such as patent right or copyright, or any other right of Fujitsu or any third party or does Fujitsu warrant non-infringement of any third-party's intellectual property right or other right by using such information. Fujitsu assumes no liability for any infringement of the intellectual property rights or other rights of third parties which would result from the use of information contained herein.

The products described in this document are designed, developed and manufactured as contemplated for general use, including without limitation, ordinary industrial use, general office use, personal use, and household use, but are not designed, developed and manufactured as contemplated (1) for use accompanying fatal risks or dangers that, unless extremely high safety is secured, could have a serious effect to the public, and could lead directly to death, personal injury, severe physical damage or other loss (i.e., nuclear reaction control in nuclear facility, aircraft flight control, air traffic control, mass transport control, medical life support system, missile launch control in weapon system), or (2) for use requiring extremely high reliability (i.e., submersible repeater and artificial satellite).

Please note that Fujitsu will not be liable against you and/or any third party for any claims or damages arising in connection with above-mentioned uses of the products.

Any semiconductor devices have an inherent chance of failure. You must protect against injury, damage or loss from such failures by incorporating safety design measures into your facility and equipment such as redundancy, fire protection, and prevention of over-current levels and other abnormal operating conditions.

If any products described in this document represent goods or technologies subject to certain restrictions on export under the Foreign Exchange and Foreign Trade Law of Japan, the prior authorization by Japanese government will be required for export of those products from Japan.

The company names and brand names herein are the trademarks or registered trademarks of their respective owners.

Edited Business Promotion Dept.