

## 15-Kilogram Scale Using the TC500A and the TC520

Author: Ted Dabney,  
Microchip Technology, Inc.

The TC500A has no agenda of its own so it can be used to generate slow, high resolution conversions or fast, low resolution conversions. The trade-off for accuracy is about 1000 counts per millisecond of integration time, i.e., 16-bits with  $T_{INT}$  approximately equal to 60mS. Typically, the total conversion time is about 4 times the integration time but, with the TC500A, this is quite flexible.

$$T_{INT} = C_{INT} R_{INT} V_{INT}/V_{IN} \text{ (max)} \quad \text{eq1}$$

The TC520 is a digital interface device which can be used to replace all of the TC500A timing and counting functions performed by a microprocessor. The TC520 can use either a crystal or external clock as a time-base to control the operation of either a TC500 or a TC500A.

### INTRODUCTION

A 15kg weighing scale was designed using Microchip's TC500A Analog Processor and the TC520 16-bit Controller. The scale is required to resolve down to 1/8 gram and correct to within 61/2 gram. This project takes into account all aspects of a functional scale:

- Dynamic Range
- Strain Gauge Compensation
- Zeroing
- Oversampling
- Units Conversion (kilograms to pounds)

The TC500A is an analog processor device which performs a dual-slope analog-to-digital conversion function. All of the counting and timing for the conversion must be controlled by an external source. In nearly all applications, this control source is a microprocessor. The microprocessor is programmed to monitor the status and to control the timing of the TC500A. It must also be programmed to count the conversion results.

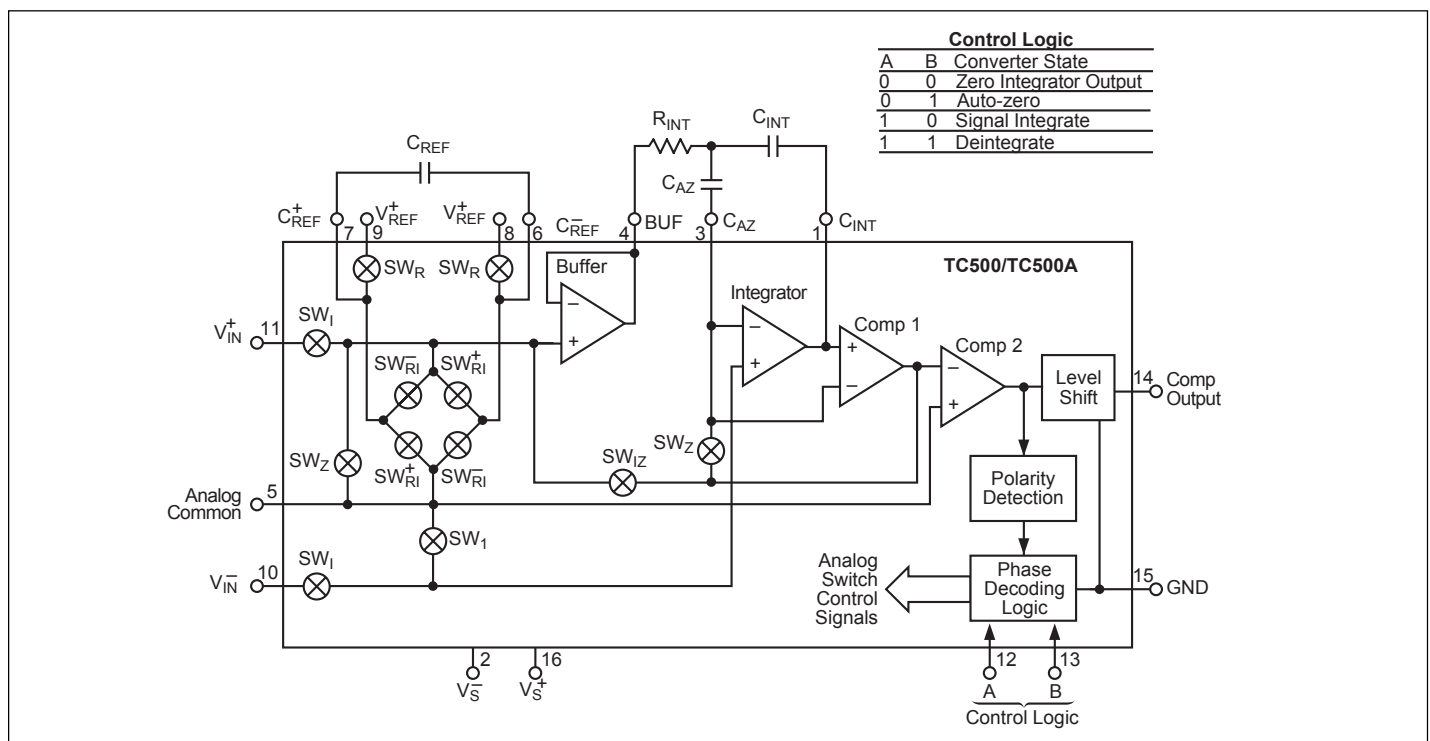

FIGURE 1: Functional block diagram.

# AN780

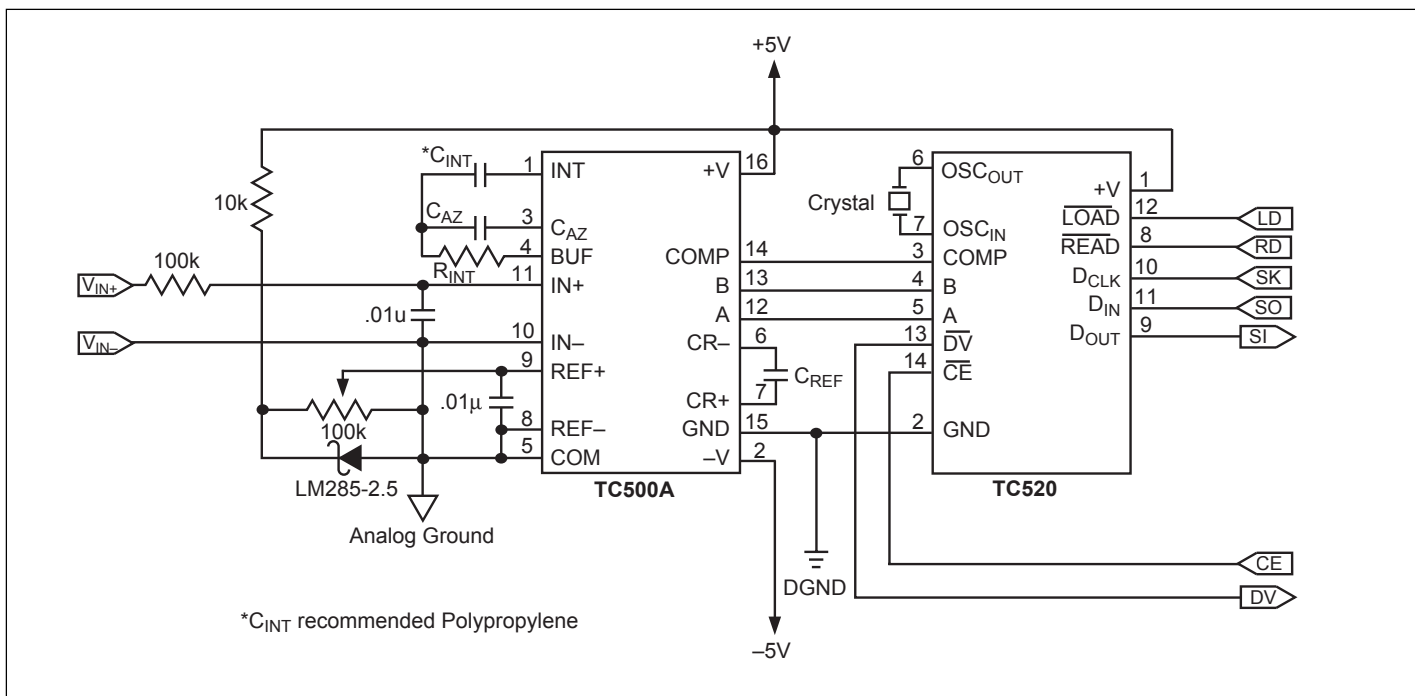

FIGURE 2: TC500A and TC520

The 16-bit conversion result is accumulated in the TC520 along with a polarity bit and an overrange bit. These bits are formed into one 18-bit serial word which may be read at any rate and at any time. Reading the serial data from the TC520 does not effect the TC500A/TC520 conversion cycle except that the output shift register will not update while reading is in progress.

## DEVELOPING THE SCALE APPLICATION USING THE TC500A AND THE TC520

### Input Stage

The first consideration for a low signal level source is the amount of gain required for the input amplifier. The TC500A has a CMOS input buffer which, due to unity-gain phase margin, must have no lower than about 68kΩ for  $R_{INT}$ . The maximum buffer current  $V_{IN(max)}/R_{INT}$  should be no more than about 20μA. This means that the maximum input voltage to the TC500A should be about 1.5V. The 15kG strain gauge used for this application has an output of about 1mV/gram which gives a gain requirement of at least 50. The MCP606 CMOS operational amplifier is best suited for this because of its low noise and minimal drift. The output impedance of the strain gauge is only 300Ω so a single-ended configuration is more than adequate. Instead of 1.5V, the actual full-scale output wound up to be about 1V. The value of  $R_{INT}$  was set to 130kΩ, well above the 68kΩ minimum. This gives a maximum buffer current of 7.6μA instead of 20μA.

### Integrator Stage

The signal-to-noise ratio of the TC500A's integrator stage is a function of the band-width. The 15kG scale needs to resolve 1g with at least 8:1 over-sampling. This means at least 120,000 counts. The above rule of "1000 counts per millisecond" requires at least 120ms for the integration time of the TC500A. Selecting 200mS will lower the band-width and get maximum rejection of 50/60Hz. The strain gauge is a balanced bridge so the output will have some common mode component. A value of 3.5V for  $V_{INT}$  instead of 4V will allow for some offset. Rearranging equation 1 gives an expression for  $C_{INT}$ :

$$C_{INT} = \frac{V_{IN} (max) T_{INT}}{V_{INT} R_{INT}} = \frac{1V \cdot 200mS}{3.5V \cdot 130k} = .439mF \quad eq2$$

The next higher common value is .47μF which was selected for  $C_{INT}$ . It is essential that this capacitor is a polypropylene type for very low dielectric absorption.

### REFERENCE VOLTAGE CIRCUIT

The differential reference voltage is derived by the standard, dual-slope ratiometric technique:

$$V_{REF} = V_{IN} (max) T_{INT}/T_{DEINT} \quad eq3$$

where  $T_{DEINT}$  is the deintegration time required for a full-scale conversion.

This application requires 120,000 counts which means that the TC520's overrange bit must be used as the MSB, i.e., 17-bits. A reference voltage with a tempco of 0.3ppm/°C would normally be required for stability over a 30°C range. This could be a prohibitive requirement. Fortunately the strain gauge has an output sensitivity which is directly proportional to the supply voltage applied,

$$V_{SG} = K (V^+ - V^-) P_{SG}, \quad \text{eq3/a}$$

where K is the constant for a particular strain gauge and the dual slope converter produces a result which is inversely proportional to its reference voltage:

$$T_{DEINT} = V_{IN} T_{INT} / V_{REF}$$

By deriving the reference from the supply voltage, any variations will exactly cancel.

$$V_{REF} = R_{REF} \times (V^+ - V^-) / R_{TOTAL} \quad \text{eq3/b}$$

The TC500A has a differential reference input so the reference voltage need not be referenced to ground. Rather than using a precision reference for the TC500A and a precision supply for the strain gauge, combining eq3/a and eq3/b into eq4 produces an equation for the system:

$$T_{DEINT} = K G P_{SG} T_{INT} R_{TOTAL} / R_{REF} \quad \text{eq4}$$

Notice that  $V_{IN}$  has been replaced by an expression for the pressure on the strain gauge ( $P_{SG}$ ), the strain gage constant (K) and the gain of the amplifier (G). The actual differential reference voltage is determined only by the ratio of resistance values ( $R_{TOTAL} / R_{REF}$ ).

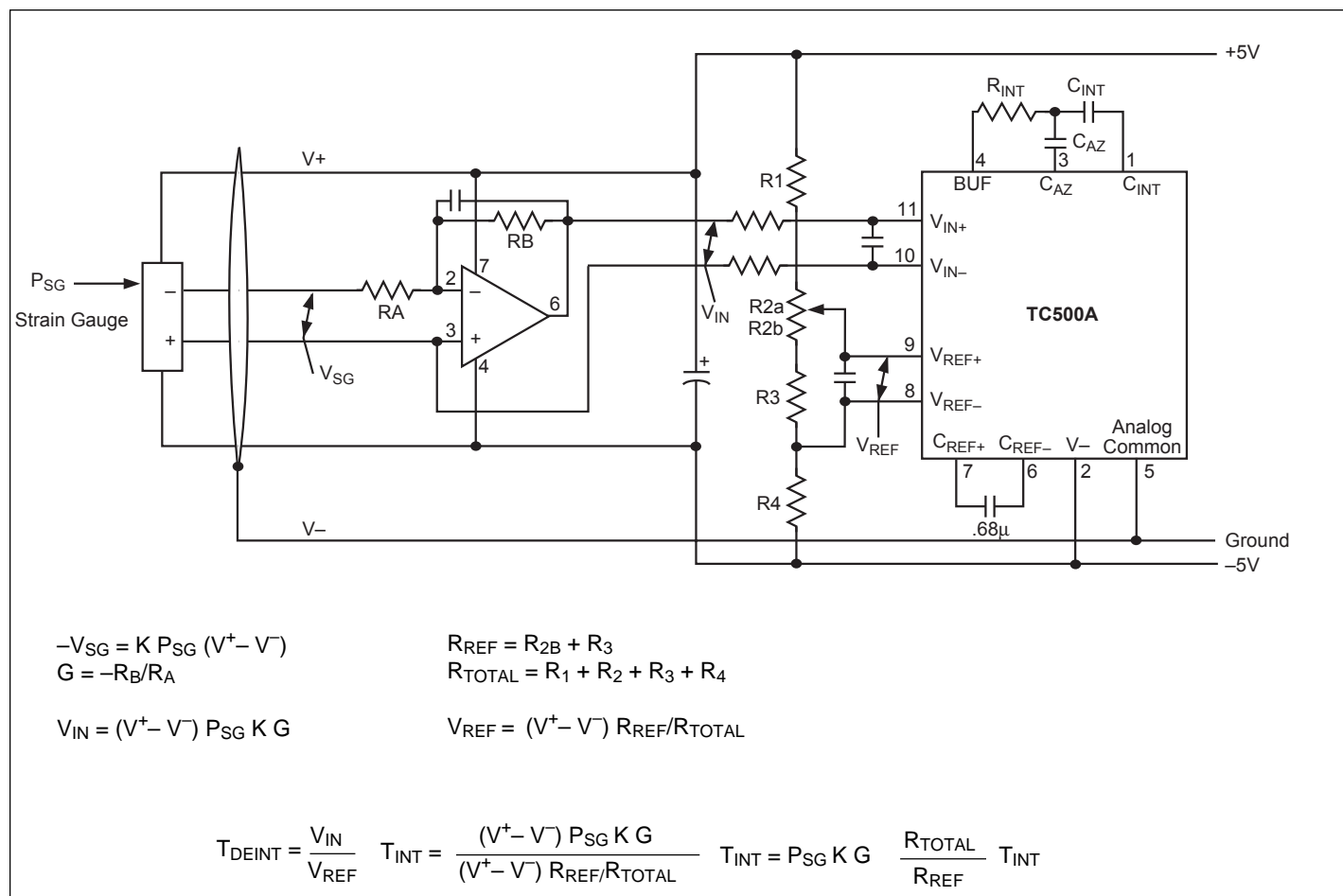

**FIGURE 3:** Differential ratiometric reference voltage.

# AN780

---

## AUTO-ZERO AND REFERENCE CAPACITORS

The voltage on these capacitors stay very constant so dielectric absorption is not a consideration. The long integration time does require capacitors with very low leakage. A .68 $\mu$ F polyester capacitor was used in both cases.

## TC520 TIMING

A 200ms integration time is already selected. There are a few options available with the TC520 to do this. The exact crystal (or clock rate) can be select in conjunction with one of the two default timings in the TC520 or, the microprocessor can be used to program the TC520 for the proper timing with some arbitrary crystal frequency. The main constraint is that the TC500A has a comparator delay of about 4 $\mu$ S. Also, the TC520 has a divide-by-4 on the clock input. This means that anything around 1MHz will be acceptable. The TC520 can be programmed by the micro to set the actual integration time to within approximately .5ms. The crystal used in this application is 1.0703MHz.

There are 4 clocks/count in the TC520 and the base integration counter is 256 counts. This calculates to a timebase period of 0.9567mS with the crystal being used. The 200mS integration time requires 209 timebase periods. Since the TC520 gives 256 timebase periods, 47 of them need to be taken away. The value can be determined from the equation:

$$N = 256 - \frac{f_{OSC} \times T_{INT}}{1024} = 256 - \frac{1.0703\text{MHz} \times 200\text{mS}}{1024} = 46.957$$

The micro was programmed to load a "47" (2F<sub>H</sub>) into the TC520 at the start of the program. This will cause the TC500A to have an integration time of 199.96mS. This value will give at least 120dB of rejection at 50/60Hz.

The TC520 will also use the integration timing for the TC500A's Auto-Zero phase. A 17-bit conversion will require a deintegration time which is a function of the oscillator frequency, i.e.,  $2^{17} \times 4 \div f_{OSC} = 490\text{mS}$ .

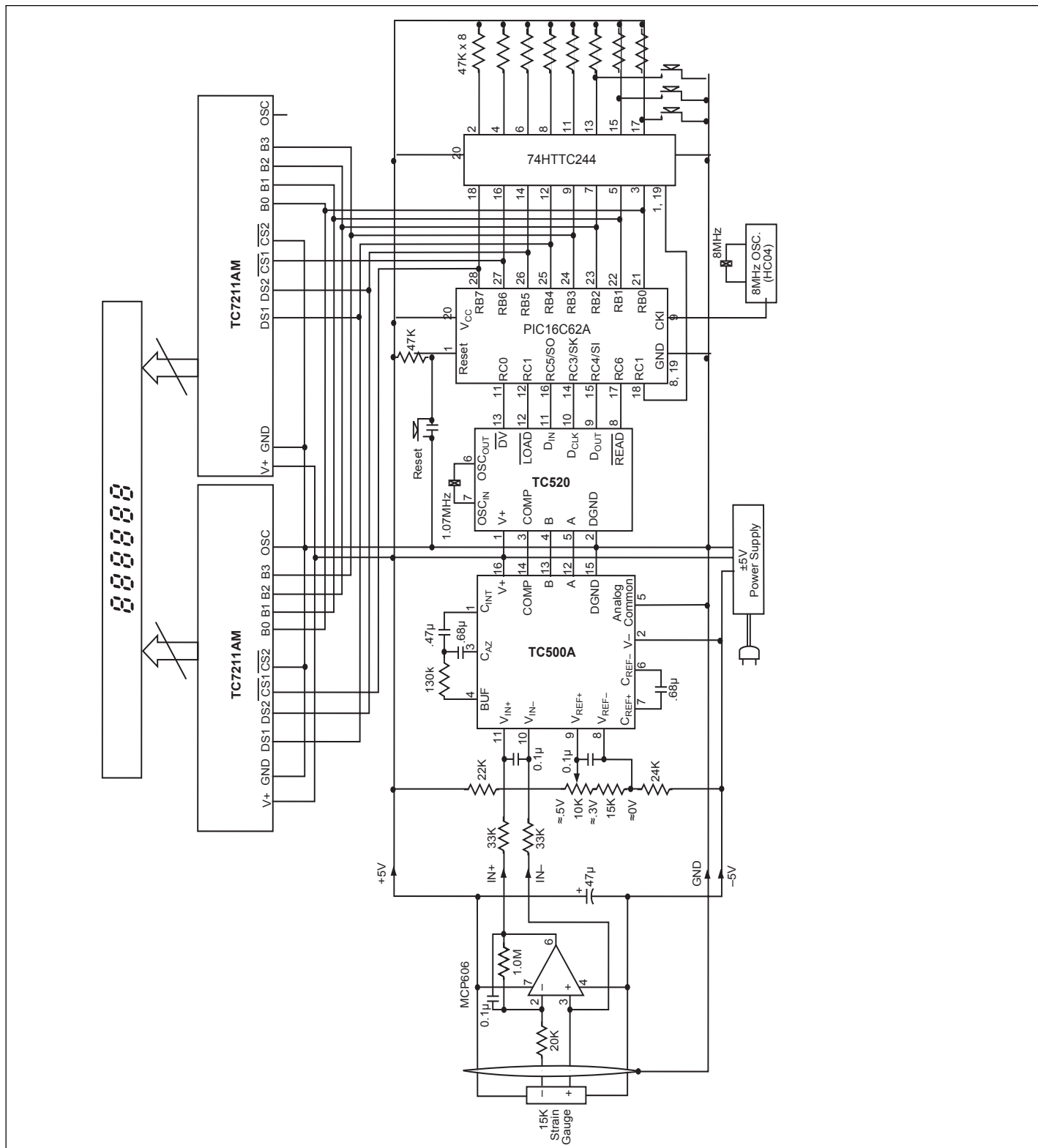

**FIGURE 4:** Kilogram scale schematic.

# AN780

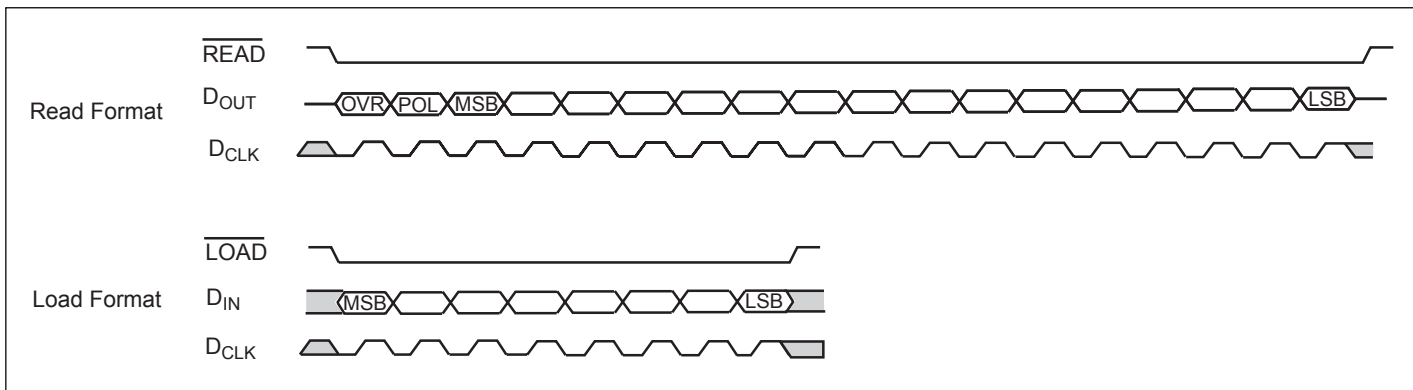

FIGURE 5: Serial interface protocol.

## REFERENCE VOLTAGE CALCULATION

Now that the timing has been determined, eq3 can be used to calculate the reference voltage:

$$\begin{aligned} V_{\text{REF}} &= V_{\text{IN}}(\text{max}) T_{\text{INT}}/T_{\text{DCINT}} \\ &= 1\text{V} 200\text{mS}/490\text{mS} \approx .408\text{V} \end{aligned}$$

The reference voltage does not need to be calculated very precise since it will have to be trimmed during calibration. A  $\pm 25\%$  adjustment range is enough to make up for just about any minor calculation error.

## MICROPROCESSOR PROGRAMMING

The PIC16C62A 8-Bit microcontroller was selected but any reasonable processor/controller will suffice. The PIC16C62A is a 28-pin part that has EPROM programmability.

## CONCLUSION

The scale works extremely well. The 8X oversampling makes it very smooth and noise-free. The response time is within one conversion ( $\approx 1/2$  sec) for changes of 2 grams or more. Changes of less than 2 grams are accumulated in an integrating register until it gets to either +1 gram or -1 gram. When this happens, the current conversion is allowed to "get through" and a new base is established in the accumulator.

There is also a facility in the programming that allows the raw data to be displayed. These displays show the full 17-bit conversion results. The basic converter noise is as predicted, typically 1 to 2 counts of flicker (16-bit accuracy) with an intermittent jump of about 3 or 4 counts ( $1/f$  noise). One count is equivalent to  $1/8$  gram.

The actually 60Hz power line rejection ration of the TC500A was not measured, but judging from the 6 to 8 counts of "rolling noise" before preloading the TC520 with  $2F_{\text{H}}$ , it is quite adequate.

The effect of the differential ratiometric reference was tested by changing the supply voltage from +4V to +6V. Although there was a 1 – 2 second delay due to unmatched time constants between the reference and the strain gauge, the final readings were exactly the same. This shows that the power supply rejection is better than 100dB.

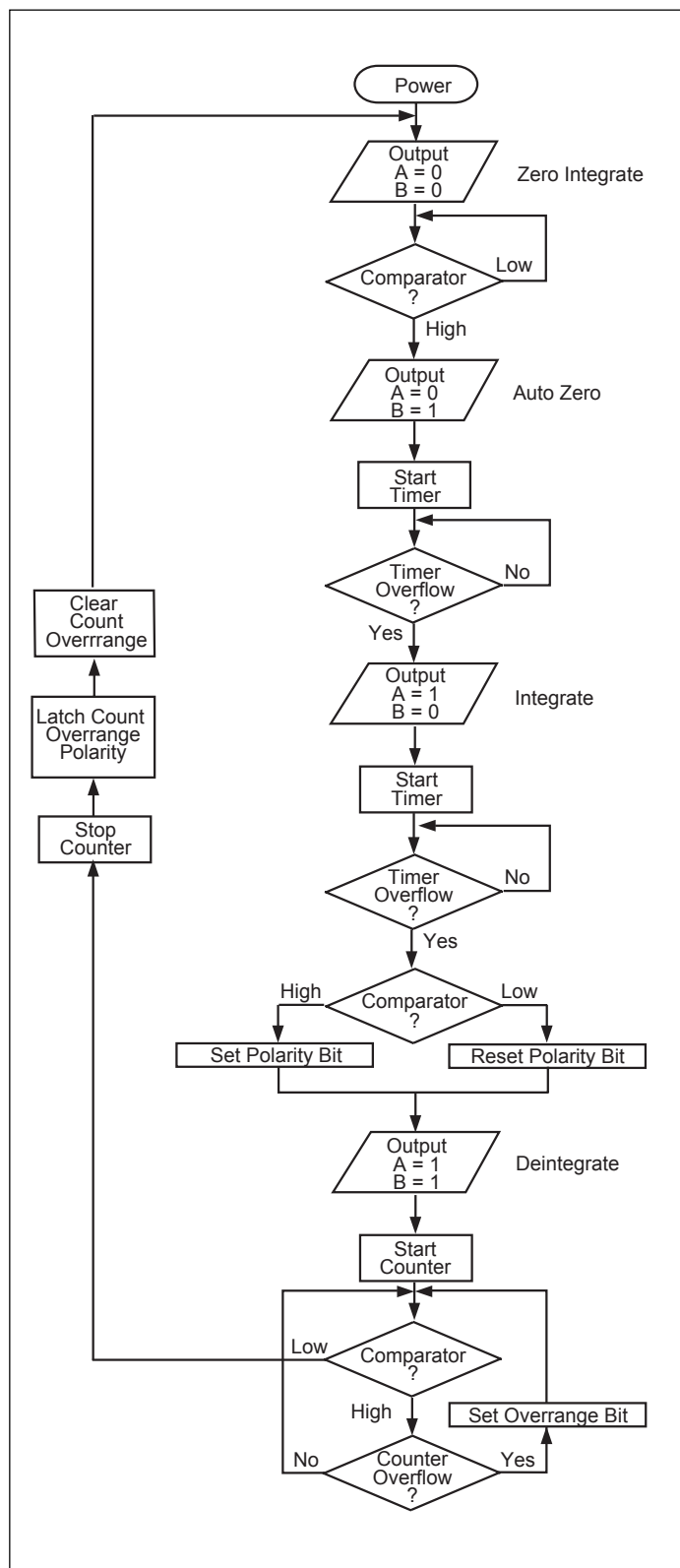

FIGURE 6: TC520 program flow chart.

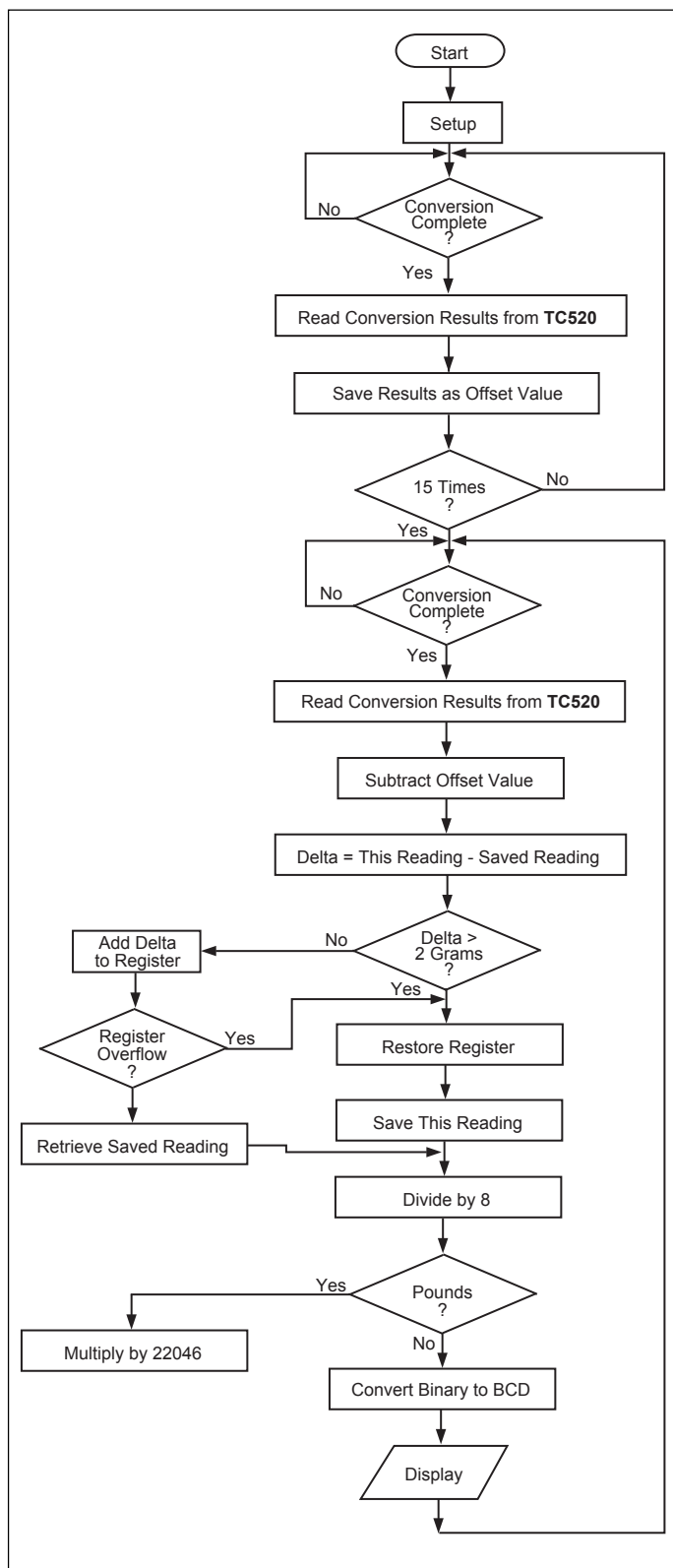

FIGURE 7: PIC16C62A program flow chart.

# AN780

---

NOTES:



---

Information contained in this publication regarding device applications and the like is intended through suggestion only and may be superseded by updates. It is your responsibility to ensure that your application meets with your specifications. No representation or warranty is given and no liability is assumed by Microchip Technology Incorporated with respect to the accuracy or use of such information, or infringement of patents or other intellectual property rights arising from such use or otherwise. Use of Microchip's products as critical components in life support systems is not authorized except with express written approval by Microchip. No licenses are conveyed, implicitly or otherwise, under any intellectual property rights.

#### Trademarks

The Microchip name and logo, the Microchip logo, FilterLab, KEELOQ, microID, MPLAB, PIC, PICmicro, PICMASTER, PICSTART, PRO MATE, SEEVAL and The Embedded Control Solutions Company are registered trademarks of Microchip Technology Incorporated in the U.S.A. and other countries.

dsPIC, ECONOMONITOR, FanSense, FlexROM, fuzzyLAB, In-Circuit Serial Programming, ICSP, ICEPIC, microPort, Migratable Memory, MPASM, MPLIB, MPLINK, MPSIM, MXDEV, PICC, PICDEM, PICDEM.net, rfPIC, Select Mode and Total Endurance are trademarks of Microchip Technology Incorporated in the U.S.A.

Serialized Quick Turn Programming (SQTP) is a service mark of Microchip Technology Incorporated in the U.S.A.

All other trademarks mentioned herein are property of their respective companies.

© 2002, Microchip Technology Incorporated, Printed in the U.S.A., All Rights Reserved.

 Printed on recycled paper.

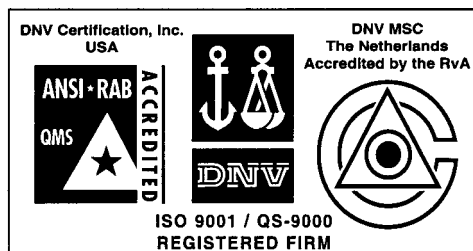

*Microchip received QS-9000 quality system certification for its worldwide headquarters, design and wafer fabrication facilities in Chandler and Tempe, Arizona in July 1999. The Company's quality system processes and procedures are QS-9000 compliant for its PICmicro® 8-bit MCUs, KEELOQ® code hopping devices, Serial EEPROMs and microperipheral products. In addition, Microchip's quality system for the design and manufacture of development systems is ISO 9001 certified.*



# MICROCHIP

## WORLDWIDE SALES AND SERVICE

### AMERICAS

#### Corporate Office

2355 West Chandler Blvd.  
Chandler, AZ 85224-6199  
Tel: 480-792-7200 Fax: 480-792-7277  
Technical Support: 480-792-7627  
Web Address: <http://www.microchip.com>

#### Rocky Mountain

2355 West Chandler Blvd.  
Chandler, AZ 85224-6199  
Tel: 480-692-7966 Fax: 480-792-7456

#### Atlanta

500 Sugar Mill Road, Suite 200B  
Atlanta, GA 30350  
Tel: 770-640-0034 Fax: 770-640-0307

#### Boston

2 Lan Drive, Suite 120  
Westford, MA 01886  
Tel: 978-692-3848 Fax: 978-692-3821

#### Chicago

333 Pierce Road, Suite 180  
Itasca, IL 60143  
Tel: 630-285-0071 Fax: 630-285-0075

#### Dallas

4570 Westgrove Drive, Suite 160  
Addison, TX 75001  
Tel: 972-818-7423 Fax: 972-818-2924

#### Detroit

Tri-Atria Office Building  
32255 Northwestern Highway, Suite 190  
Farmington Hills, MI 48334  
Tel: 248-538-2250 Fax: 248-538-2260

#### Kokomo

2767 S. Albright Road  
Kokomo, Indiana 46902  
Tel: 765-864-8360 Fax: 765-864-8387

#### Los Angeles

18201 Von Karman, Suite 1090  
Irvine, CA 92612  
Tel: 949-263-1888 Fax: 949-263-1338

#### New York

150 Motor Parkway, Suite 202  
Hauppauge, NY 11788  
Tel: 631-273-5305 Fax: 631-273-5335

#### San Jose

Microchip Technology Inc.  
2107 North First Street, Suite 590  
San Jose, CA 95131  
Tel: 408-436-7950 Fax: 408-436-7955

#### Toronto

6285 Northam Drive, Suite 108  
Mississauga, Ontario L4V 1X5, Canada  
Tel: 905-673-0699 Fax: 905-673-6509

### ASIA/PACIFIC

#### Australia

Microchip Technology Australia Pty Ltd  
Suite 22, 41 Rawson Street  
Epping 2121, NSW  
Australia  
Tel: 61-2-9868-6733 Fax: 61-2-9868-6755

#### China - Beijing

Microchip Technology Consulting (Shanghai)  
Co., Ltd., Beijing Liaison Office  
Unit 915  
Bei Hai Wan Tai Bldg.  
No. 6 Chaoyangmen Beidajie  
Beijing, 100027, No. China  
Tel: 86-10-85282100 Fax: 86-10-85282104

#### China - Chengdu

Microchip Technology Consulting (Shanghai)  
Co., Ltd., Chengdu Liaison Office  
Rm. 2401, 24th Floor,  
Ming Xing Financial Tower  
No. 88 TIDU Street  
Chengdu 610016, China  
Tel: 86-28-6766200 Fax: 86-28-6766599

#### China - Fuzhou

Microchip Technology Consulting (Shanghai)  
Co., Ltd., Fuzhou Liaison Office  
Unit 28F, World Trade Plaza  
No. 71 Wusi Road  
Fuzhou 350001, China  
Tel: 86-591-7503506 Fax: 86-591-7503521

#### China - Shanghai

Microchip Technology Consulting (Shanghai)  
Co., Ltd.  
Room 701, Bldg. B  
Far East International Plaza  
No. 317 Xian Xia Road  
Shanghai, 200051  
Tel: 86-21-6275-5700 Fax: 86-21-6275-5060

#### China - Shenzhen

Microchip Technology Consulting (Shanghai)  
Co., Ltd., Shenzhen Liaison Office  
Rm. 1315, 13/F, Shenzhen Kerry Centre,  
Renminnan Lu  
Shenzhen 518001, China  
Tel: 86-755-2350361 Fax: 86-755-2366086

#### Hong Kong

Microchip Technology Hongkong Ltd.  
Unit 901-6, Tower 2, Metroplaza  
223 Hing Fong Road  
Kwai Fong, N.T., Hong Kong  
Tel: 852-2401-1200 Fax: 852-2401-3431

#### India

Microchip Technology Inc.  
India Liaison Office  
Divyasree Chambers  
1 Floor, Wing A (A3/A4)  
No. 11, O'Shaughnessey Road  
Bangalore, 560 025, India  
Tel: 91-80-2290061 Fax: 91-80-2290062

### Japan

Microchip Technology Japan K.K.  
Benex S-1 6F  
3-18-20, Shinyokohama  
Kohoku-Ku, Yokohama-shi  
Kanagawa, 222-0033, Japan  
Tel: 81-45-471-6166 Fax: 81-45-471-6122

### Korea

Microchip Technology Korea  
168-1, Youngbo Bldg. 3 Floor  
Samsung-Dong, Kangnam-Ku  
Seoul, Korea 135-882  
Tel: 82-2-554-7200 Fax: 82-2-558-5934

### Singapore

Microchip Technology Singapore Pte Ltd.  
200 Middle Road  
#07-02 Prime Centre  
Singapore, 188980  
Tel: 65-6334-8870 Fax: 65-6334-8850

### Taiwan

Microchip Technology Taiwan  
11F-3, No. 207  
Tung Hua North Road  
Taipei, 105, Taiwan  
Tel: 886-2-2717-7175 Fax: 886-2-2545-0139

### EUROPE

#### Denmark

Microchip Technology Nordic ApS  
Regus Business Centre  
Lautrup høj 1-3  
Ballerup DK-2750 Denmark  
Tel: 45 4420 9895 Fax: 45 4420 9910

#### France

Microchip Technology SARL  
Parc d'Activite du Moulin de Massy  
43 Rue du Saule Trapu  
Batiment A - 1er Etage  
91300 Massy, France  
Tel: 33-1-69-53-63-20 Fax: 33-1-69-30-90-79

#### Germany

Microchip Technology GmbH  
Gustav-Heinemann Ring 125  
D-81739 Munich, Germany  
Tel: 49-89-627-144 0 Fax: 49-89-627-144-44

#### Italy

Microchip Technology SRL  
Centro Direzionale Colleoni  
Palazzo Taurus 1 V. Le Colleoni 1  
20041 Agrate Brianza  
Milan, Italy  
Tel: 39-039-65791-1 Fax: 39-039-6899883

#### United Kingdom

Arizona Microchip Technology Ltd.  
505 Eskdale Road  
Winnersh Triangle  
Wokingham  
Berkshire, England RG41 5TU  
Tel: 44 118 921 5869 Fax: 44-118 921-5820

03/01/02

