

PNP SILICON PLANAR EPITAXIAL TRANSISTORS

**MPS2907
MPS2907A**

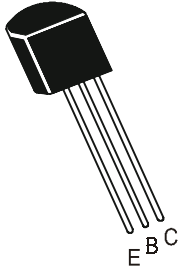

**TO-92
Plastic Package**

General Purpose Transistors

ABSOLUTE MAXIMUM RATINGS(Ta=25°C unless specified otherwise)

DESCRIPTION	SYMBOL	MPS2907	MPS2907A	UNITS
Collector Emitter Voltage	V_{CEO}	40	60	V
Collector Base Voltage	V_{CBO}		60	V
Emitter Base Voltage	V_{EBO}		5	V
Collector Current Continuous	I_C		600	mA
Power Dissipation @ Ta=25°C	P_D		625	mW
Derate Above 25°C			5	mW/°C
Power Dissipation @ Tc=25°C	P_D		1.5	W
Derate Above 25°C			12	mW/°C
Operating And Storage Junction Temperature Range	T_j, T_{stg}	-55 to +150		°C
THERMAL RESISTANCE				
Junction to ambient	$R_{th(j-a)}$		200	°C/W
Junction to case	$R_{th(j-c)}$		83.3	°C/W

PNP SILICON PLANAR EPITAXIAL TRANSISTORS

**MPS2907
MPS2907A**

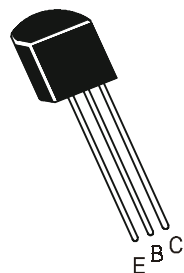

**TO-92
Plastic Package**

ELECTRICAL CHARACTERISTICS (Ta=25°C Unless Specified Otherwise)

DESCRIPTION	SYMBOL	TEST CONDITION	MPS2907		MPS2907A		UNITS
			MIN	MAX	MIN	MAX	
Collector Emitter Voltage	BV_{CEO}^*	$I_C=10mA, I_B=0$	40		60		V
Collector Base Voltage	BV_{CBO}	$I_C=10\mu A, I_E=0$	60		60		V
Emitter-Base Voltage	BV_{EBO}	$I_E=10\mu A, I_C=0$	5		5		V
Collector-Cut off Current	I_{CBO}	$V_{CB}=50V, I_E=0$ $V_{CB}=50V, I_E=0,$ $T_A=150^{\circ}C$		20		10	nA
				20		10	μA
Collector-Cut off Current	I_{CEX}	$V_{CE}=30V, V_{EB}(off)=0.5V$		50		50	nA
Collector-Cut off Current	I_{CEO}	$V_{CE}=10V$		10		10	nA
Emitter Cut off Current	I_{EBO}	$V_{EB}=3V, I_C=0$		10		10	nA
Base Cut off Current	I_{BEX}	$V_{CE}=30V, V_{EB}(off)=0.5V$		50		50	nA
Collector-Emitter Saturation Voltage	$V_{CE(sat)}^*$	$I_C=150mA, I_B=15mA$ $I_C=500mA, I_B=50mA$		0.4		0.4	V
				1.6		1.6	V
Base-Emitter Saturation Voltage	$V_{BE(sat)}^*$	$I_C=150mA, I_B=15mA$ $I_C=500mA, I_B=50mA$		1.3		1.3	V
				2.6		2.6	V
DC Current Gain	h_{FE}	$V_{CE}=10V, I_C=0.1mA$ $V_{CE}=10V, I_C=1mA$ $V_{CE}=10V, I_C=10mA$ $V_{CE}=10V^*, I_C=150mA$ $V_{CE}=10V^*, I_C=500mA$		35		75	
				50		100	
				75		100	
				100	300	100	300
				30		50	

ELECTRICAL CHARACTERISTICS (Ta=25°C Unless Specified Otherwise)

DYNAMIC CHARACTERISTICS	SYMBOL	TEST CONDITION	MPS2907		MPS2907A		UNITS
			MIN	MAX	MIN	MAX	
Transition Frequency	$f_T^{*(1)}$	$I_C=50mA, V_{CE}=20V$ $f=100MHz$	200		200		MHz
Output Capacitance	C_{ob}	$I_E=0, V_{CB}=10V$ $f=1MHz$		8		8	pF
Input Capacitance	C_{ib}	$I_C=0, V_{EB}=2V$ $f=1MHz$		30		30	pF

PNP SILICON PLANAR EPITAXIAL TRANSISTORS

**MPS2907
MPS2907A**

**TO-92
Plastic Package**

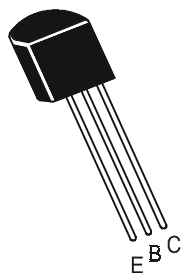

SWITCHING CHARACTERISTICS	SYMBOL	TEST CONDITION	MPS2907		MPS2907A		UNITS
			MIN	MAX	MIN	MAX	
		$I_C = 150\text{mA}, I_{B1} = 15\text{mA},$ $V_{CC} = 30\text{V}$					
Delay Time	t_d			10		10	ns
Rise Time	t_r			40		40	ns
Turn On Time	t_{on}			45		45	ns
		$I_C = 150\text{mA}, I_{B1} = I_{B2} = 15\text{mA},$ $V_{CC} = 6\text{V}$					
Storage Time	t_s			80		80	ns
Fall Time	t_f			30		30	ns
Turn Off Time	t_{off}			100		100	ns

*Pulse Condition: Width $\leq 300\mu\text{s}$, Duty Cycle $\leq 2\%$.

⁽¹⁾ f_T is defined as the frequency at which $|h_{fe}|$ extrapolates to unity.

TO-92 Plastic Package

TO-92 Transistors on Tape and Ammo Pack

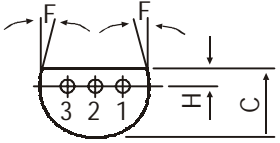
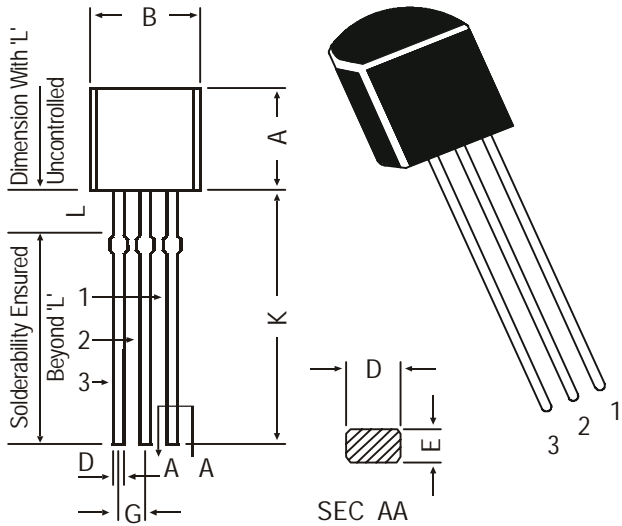

PIN CONFIGURATION
 1. COLLECTOR
 2. BASE
 3. EMITTER

DIM	MIN.	MAX.
A	4.32	5.33
B	4.45	5.20
C	3.18	4.19
D	0.41	0.55
E	0.35	0.50
F	5 DEG	
G	1.14	1.40
H	1.14	1.53
K	12.70	—
L	1.982	2.082

All dimensions in mm.

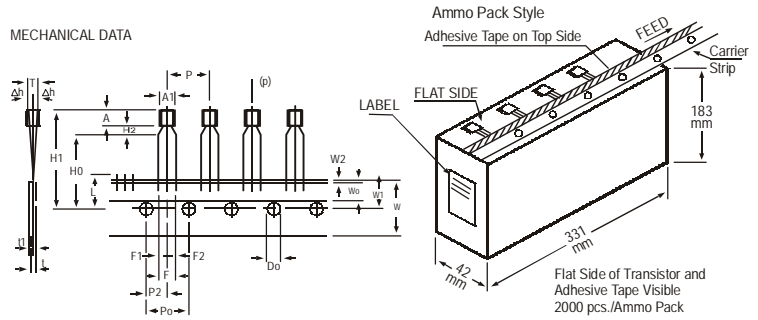

All dimensions in mm unless specified otherwise

ITEM	SYMBOL	SPECIFICATION				REMARKS
		MIN.	NOM.	MAX.	TOL.	
BODY WIDTH	A1	4.0		4.8		
BODY HEIGHT	A	4.8		5.2		
BODY THICKNESS	T	3.9		4.2		
PITCH OF COMPONENT	P		12.7		±0.1	
FEED HOLE PITCH	Po		12.7		±0.3	CUMULATIVE PITCH ERROR 1.0 mm/20 PITCH
FEED HOLE CENTRE TO COMPONENT CENTRE	P2		6.35		±0.4	TO BE MEASURED AT BOTTOM OF CLINCH
DISTANCE BETWEEN OUTER LEADS	F		5.08		+0.6 -0.2	AT TOP OF BODY
COMPONENT ALIGNMENT	Δh		0	1		
TAPE WIDTH	W		18		±0.5	
HOLD-DOWN TAPE WIDTH	W0		6		±0.2	
HOLE POSITION	W1		9		+0.7 -0.5	
HOLD-DOWN TAPE POSITION	W2		0.5		±0.2	
LEAD WIRE CLINCH HEIGHT	H0		16		±0.5	
COMPONENT HEIGHT	H1			23.25		
LENGTH OF SNIPPED LEADS	L			11.0		
FEED HOLE DIAMETER	Do		4		±0.2	
TOTAL TAPE THICKNESS	t			1.2		11 0.3 - 0.6
LEAD - TO - LEAD DISTANCE F1,	F2		2.54		+0.4 -0.1	
CLINCH HEIGHT	H2			3		
PULL - OUT FORCE	(P)	6N				

NOTES

1. MAXIMUM ALIGNMENT DEVIATION BETWEEN LEADS NOT TO BE GREATER THAN 0.2 mm.
2. MAXIMUM NON-CUMULATIVE VARIATION BETWEEN TAPE FEED HOLES SHALL NOT EXCEED 1 mm IN 20 PITCHES.
3. HOLDDOWN TAPE NOT TO EXCEED BEYOND THE EDGE(S) OF CARRIER TAPE AND THERE SHALL BE NO EXPOSURE OF ADHESIVE.
4. NO MORE THAN 3 CONSECUTIVE MISSING COMPONENTS ARE PERMITTED.
5. A TAPE TRAILER, HAVING AT LEAST THREE FEED HOLES ARE REQUIRED AFTER THE LAST COMPONENT.
6. SPLICES SHALL NOT INTERFERE WITH THE SPROCKET FEED HOLES.

Packing Detail

PACKAGE	STANDARD PACK		INNER CARTON BOX		OUTER CARTON BOX		
	Details	Net Weight/Qty	Size	Qty	Size	Qty	Gr Wt
TO-92 Bulk	1K/polybag	200 gm/1K pcs	3" x 7.5" x 7.5"	5K	17" x 15" x 13.5"	80K	23 kgs
TO-92 T&A	2K/ammo box	645 gm/2K pcs	12.5" x 8" x 1.8"	2K	17" x 15" x 13.5"	32K	12.5 kgs