



BOURNS®

Features

- Integrated digital contacting encoder with momentary switch option
- Mounts directly to the PCB
- Can be integrated into any circuit
- Detented versions available
- Long operating life

Applications

- Medical instrumentation
- Test and measurement equipment
- Audio equipment
- Climate control
- Home lighting
- Home automation

01943-2 Series Front Mount Module with Switch

Bourns 01943-2 Series Front Mount Module with Switch is designed for integration into any Printed Circuit Board and completes the value-added solution for Integrated Panel Control applications. Competitive features result in cost savings, reduced inventory, and improved reliability.

Encoder Characteristics

Closed Circuit Resistance	5 ohms maximum
Open Circuit Resistance	100 K ohms minimum
Contact Rating	10 milliamps @ 10 VDC
Electrical Travel	Continuous

Environmental Characteristics

Operating Temperature Range	-40 °C to +125 °C
Storage Temperature Range	-40 °C to +140 °C
Life	200 K revolutions
Vibration	15 G
Humidity	Per MIL-STD-202, Method 103B, Condition B

Switch Characteristics

Contact Push Momentary	SPST N.O.
Power Rating (Resistive Load)	10 milliamp @ 12 VDC
Closed Switch Resistance	<200 ohms @ 440 gram force
Switch Travel	2.25 ± 0.25 mm
Switch Activation Force	370 ± 70 grams

Product Dimensions

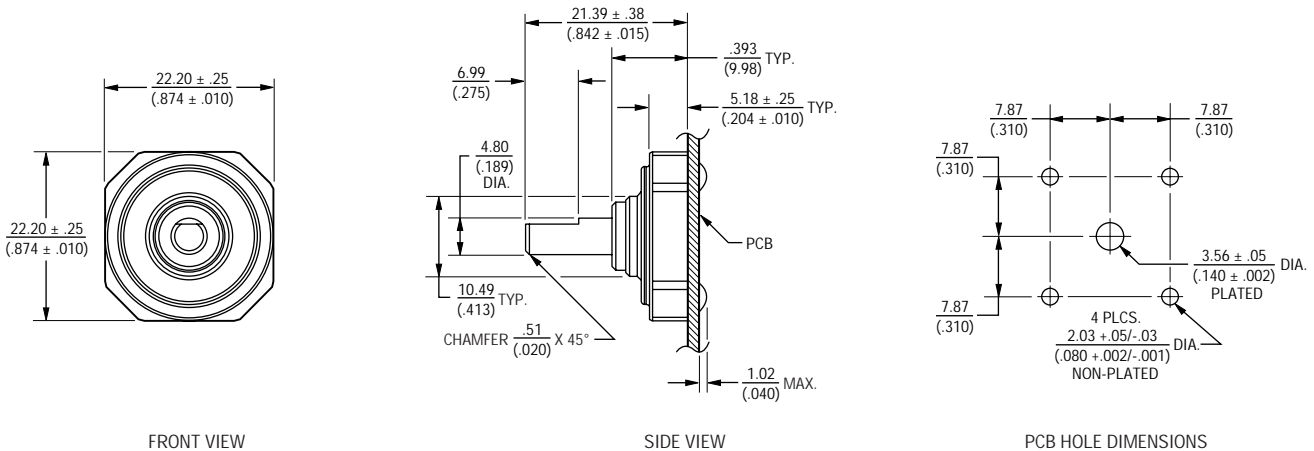

DIMENSIONS: $\frac{\text{MM}}{\text{(IN.)}}$

01943-2 Series Front Mount Module with Switch



How To Order

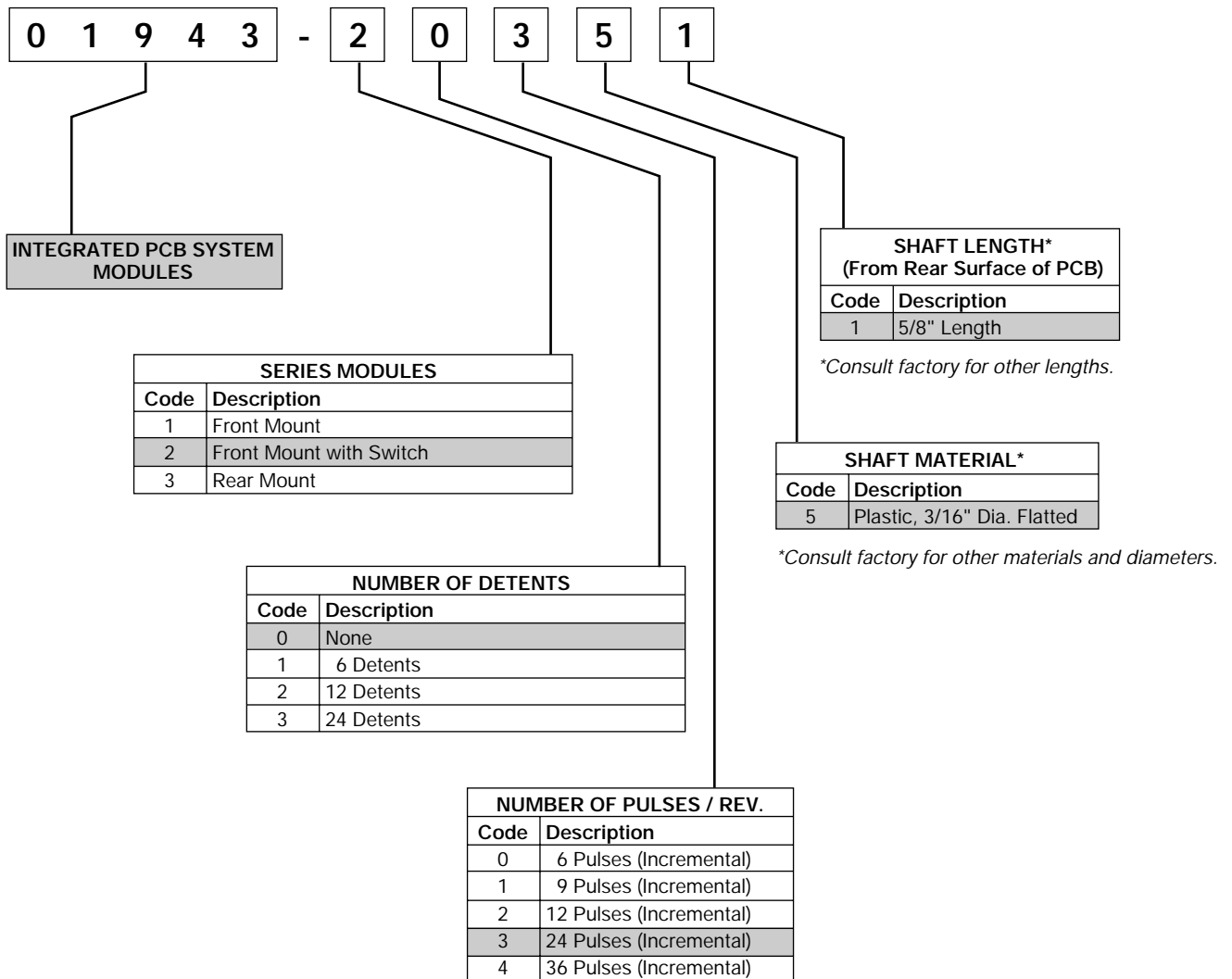

NOTE: This chart illustrates the numbering system for the module level only. Each Integrated PCB system will require several modules in addition to the PCB and electronic components that are unique to each application.