

## NPN Silicon Epitaxial Planar Transistor

## 2SC3930W

### FEATURES

- High transition frequency  $f_T$ .
- Optimum for RF amplification of FM/AM radios.
- For high-frequency amplification complementary to 2SA1532.

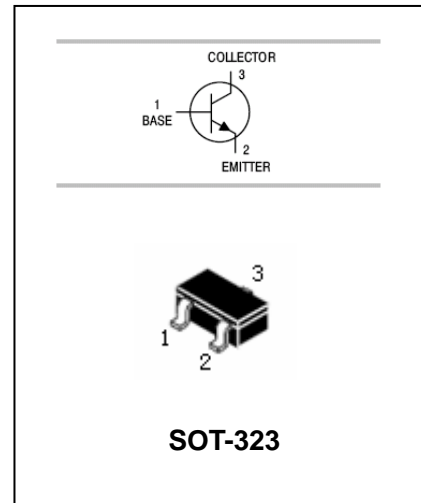

### APPLICATIONS

- Audio frequency general purpose amplifier.

### ORDERING INFORMATION

Type No.	Marking	Package Code
2SC3930W	VB/VC	SOT-323

### MAXIMUM RATING @ $T_a=25^\circ\text{C}$ unless otherwise specified

Symbol	Parameter	Value	Units
$V_{CBO}$	Collector-Base Voltage	30	V
$V_{CEO}$	Collector-Emitter Voltage	20	V
$V_{EBO}$	Emitter-Base Voltage	5	V
$I_C$	Collector Current -Continuous	30	mA
$P_C$	Collector Dissipation	150	mW
$T_j, T_{stg}$	Junction and Storage Temperature	-55~150	$^\circ\text{C}$

## NPN Silicon Epitaxial Planar Transistor

## 2SC3930W

### ELECTRICAL CHARACTERISTICS @ Ta=25°C unless otherwise specified

Parameter	Symbol	Test conditions	MIN	TYP	MAX	UNIT
Collector-base breakdown voltage	$V_{(BR)CBO}$	$I_C=100\mu A, I_E=0$	30			V
Collector-emitter breakdown voltage	$V_{(BR)CEO}$	$I_C=100\mu A, I_B=0$	20			V
Emitter-base breakdown voltage	$V_{(BR)EBO}$	$I_E=100\mu A, I_C=0$	5			V
Collector cut-off current	$I_{CBO}$	$V_{CB}=10V, I_E=0$			0.1	$\mu A$
Emitter cut-off current	$I_{EBO}$	$V_{EB}=5V, I_C=0$			0.1	$\mu A$
DC current gain	$h_{FE}$	$V_{CE}=10V, I_C=1mA$	70		220	
Transition frequency	$f_T$	$V_{CE}=10V, I_E=1mA$ $f=200MHz$	150			MHz
Common emitter reverse transfer capacitance	$C_{re}$	$V_{CE}=10V, I_E=1mA$ $f=10.7MHz$		1.5		pF
Noise figure	NF	$V_{CB}=10V, I_C=1mA, f=5MHz$		4		dB
Reverse transfer impedance	$Z_{rb}$	$V_{CB}=10V, I_C=1mA, f=2MHz$		50		$\Omega$

### CLASSIFICATION OF $h_{FE}$

Marking	VB	VC
$h_{FE}$	70-140	110-220

### TYPICAL CHARACTERISTICS @ Ta=25°C unless otherwise specified

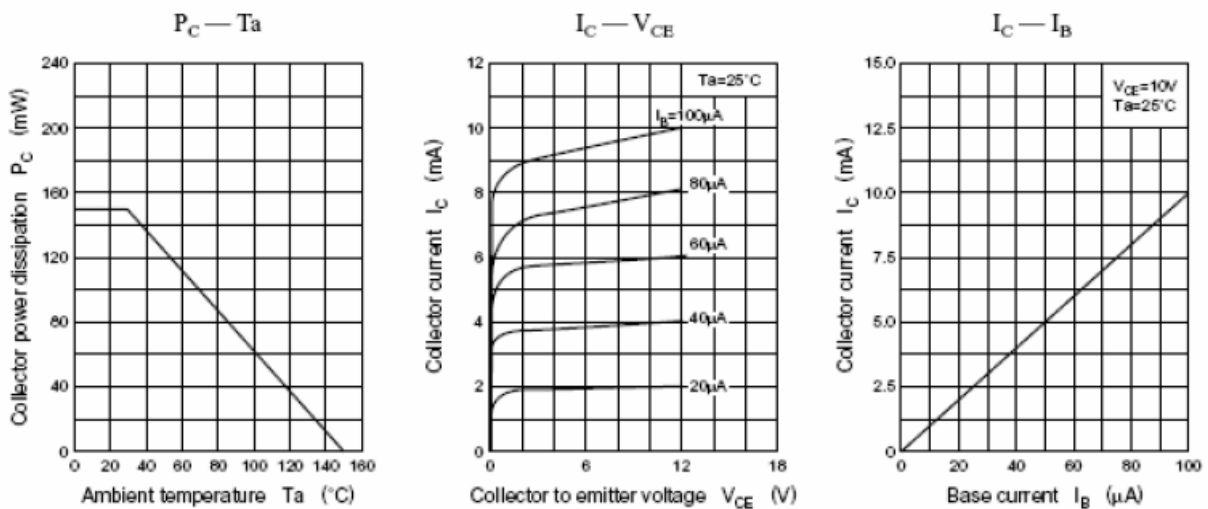

## NPN Silicon Epitaxial Planar Transistor

## 2SC3930W

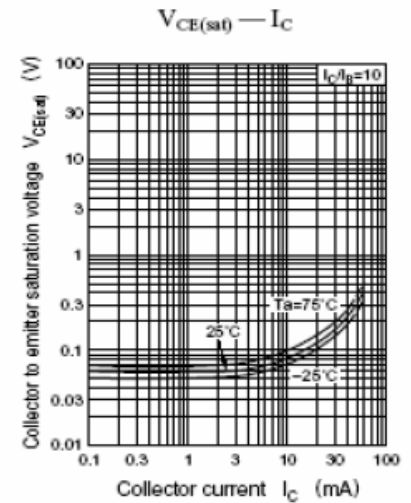
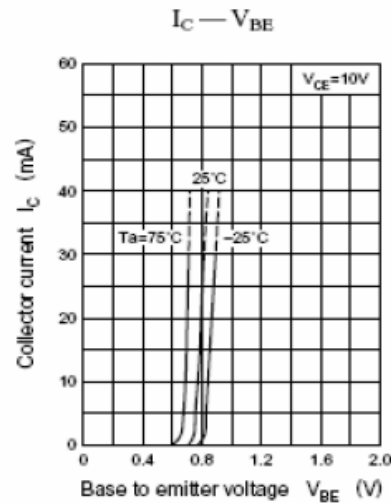
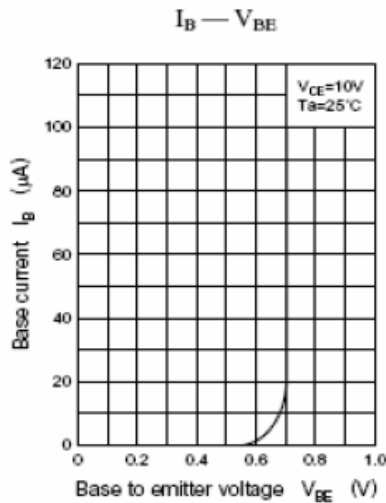
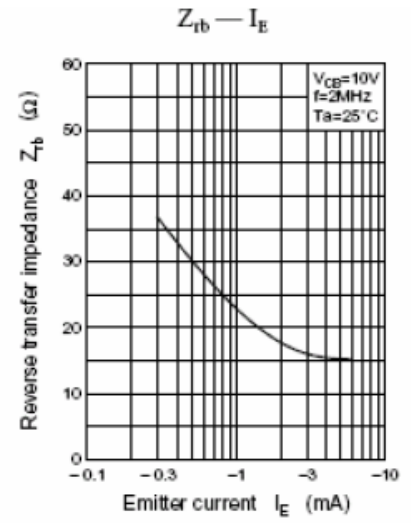
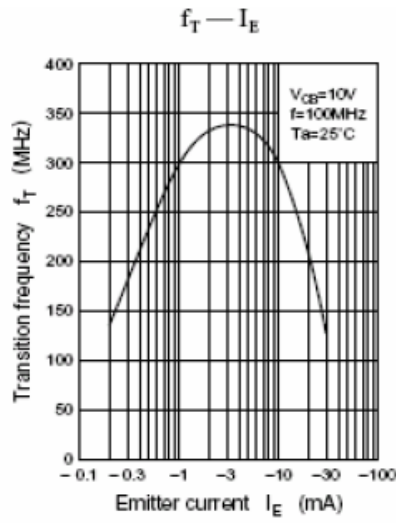
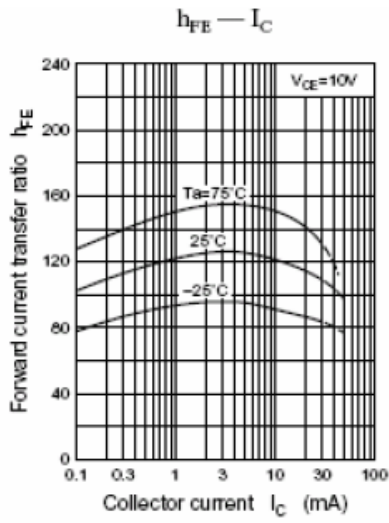

## NPN Silicon Epitaxial Planar Transistor

## 2SC3930W

### PACKAGE OUTLINE

Plastic surface mounted package

SOT-323

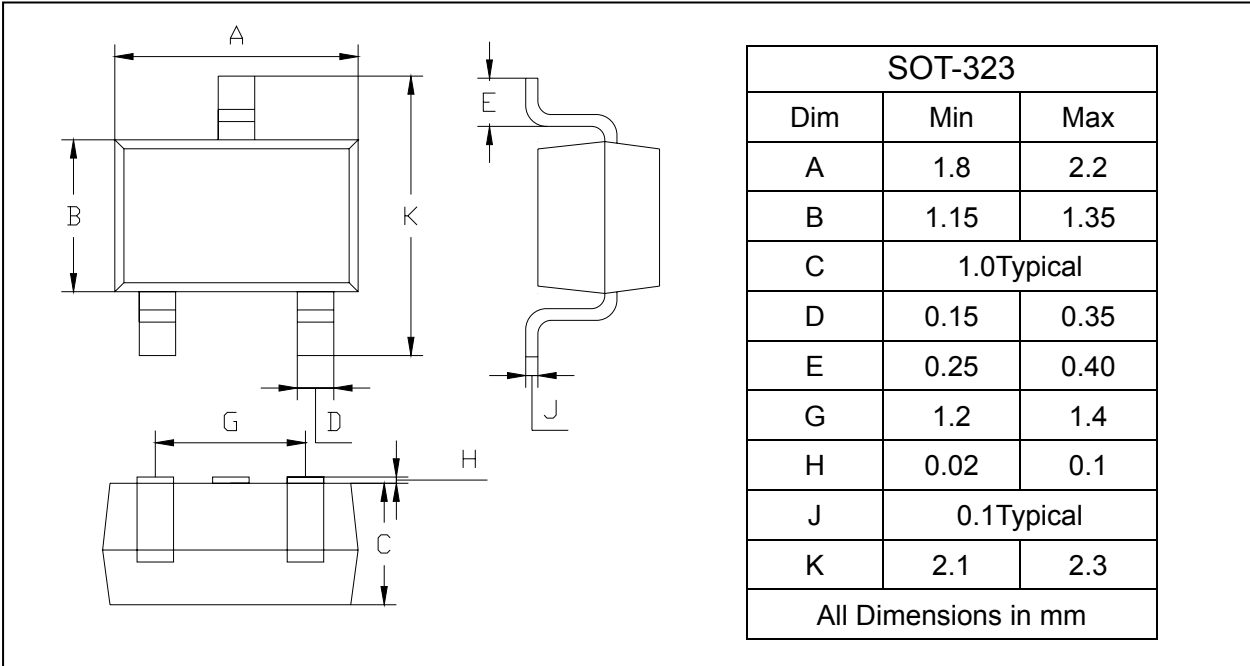

### PACKAGE INFORMATION

Device	Package	Shipping
2SC3930W	SOT-323	3000/Tape&Reel