

6 - 18 GHz High Power Amplifier

GaAs Monolithic Microwave IC

Preliminary

Description

The **CHA6517** is a Dual channel monolithic three-stage GaAs high power amplifier designed for wide band applications.

This device is manufactured using a UMS 0.25 μm Power pHEMT process, including, via holes through the substrate and air bridges.

To simplify the assembly process:

- the backside of the chip is both RF and DC grounded
- bond pads and back side are gold plated for compatibility with eutectic die attach method and thermosonic or thermocompression bonding process.

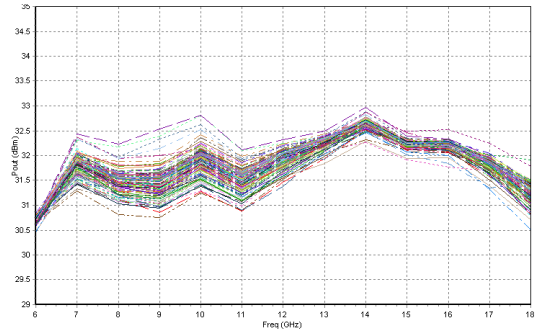

Output Power versus Frequency

Main Features

- 0.25 μm Power pHEMT Technology
- 6 – 18 GHz Frequency Range
- 32dBm Output Power per channel
- Compatible for balanced configuration
- 22dB nominal Gain
- Quiescent Bias point : 600mA @ 8V per channel
- Chip size: 4.32 x 3.90 x 0.07 mm

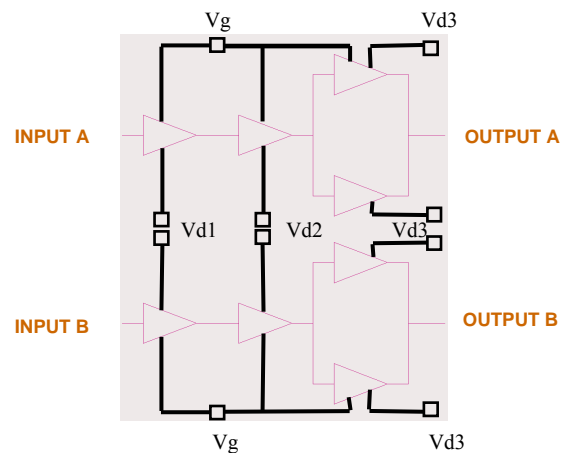

Main Characteristics

$T_{amb} = +25^{\circ}\text{C}$ (T_{amb} is the back-side of the chip)

Symbol	Parameter	Min	Typ	Max	Unit
F _{op}	Operating frequency range	6		18	GHz
Psat	Saturated output power	30	32		dBm
G _{lin}	Linear gain	19	22		dB

Electrical Characteristics

Preliminary

Tamb = 25°C (2), Vd=8V, Id (Quiescent) = 0.6A, Pu lused biasing mode, each channel

Symbol	Parameter	Min	Typ	Max	Unit
F_op	Operating frequency	6		18	GHz
G_lin	Linear gain (Pin=-5dBm)	19	22		dB
RL_in	Input Return Loss		-14	-8	dB
RL_out	Output Return Loss		-8	-4	dB
Psat	Saturated output power (Pin=11dBm)	30	32		dBm
PAE_sat	Power Added Efficiency in saturation		15		%
Vd	Positive supply voltage		8		V
Id	Power supply quiescent current (1)		0.6		A
Vg	Negative supply voltage		-0.4		V
Top	Operating temperature range (2)	-40		+70	°C

(1) This parameter is fixed by gate voltage Vg

(2) The reference is the back-side of the chip

Absolute Maximum Ratings (1)

Symbol	Parameter	Values	Unit
Pin (2)	Maximum Input power	19	dBm
Vd (2)	Positive supply voltage without RF power	8.5	V
Id (2)	Positive supply quiescent current	1	A
Pd (2)	Power dissipation	13.5	W
Tj	Junction temperature	175	°C
Tstg	Storage temperature range	-55 to +125	°C

(1) Operation of this device above any of these parameters may cause permanent damage.

(2) These values are specified for Tamb = 25°C

Typical measured characteristics

Preliminary

On Wafer Measurements, S parameters (one channel):
Tamb=25°C, Vd=8V, Id (Quiescent) = 0.6A, pulsed mo de:

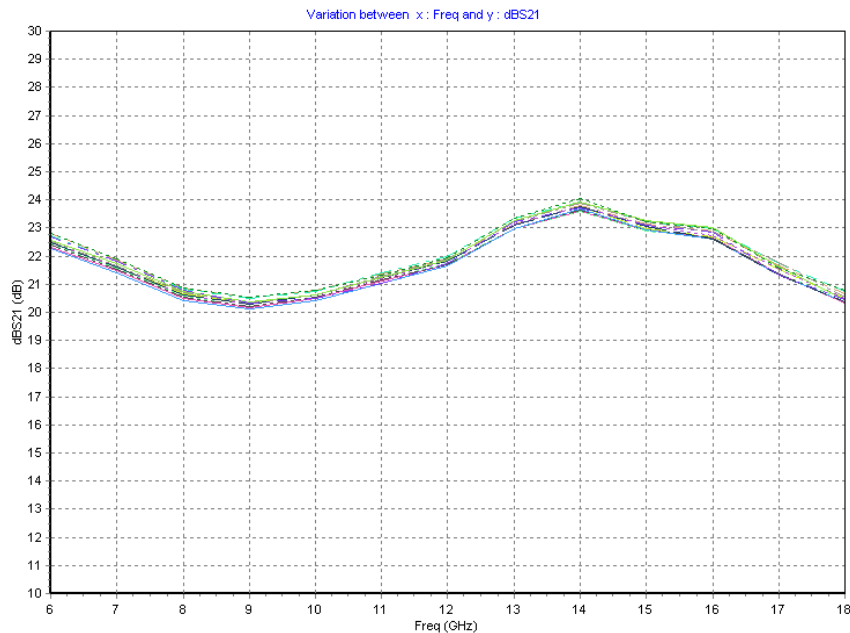

Gain

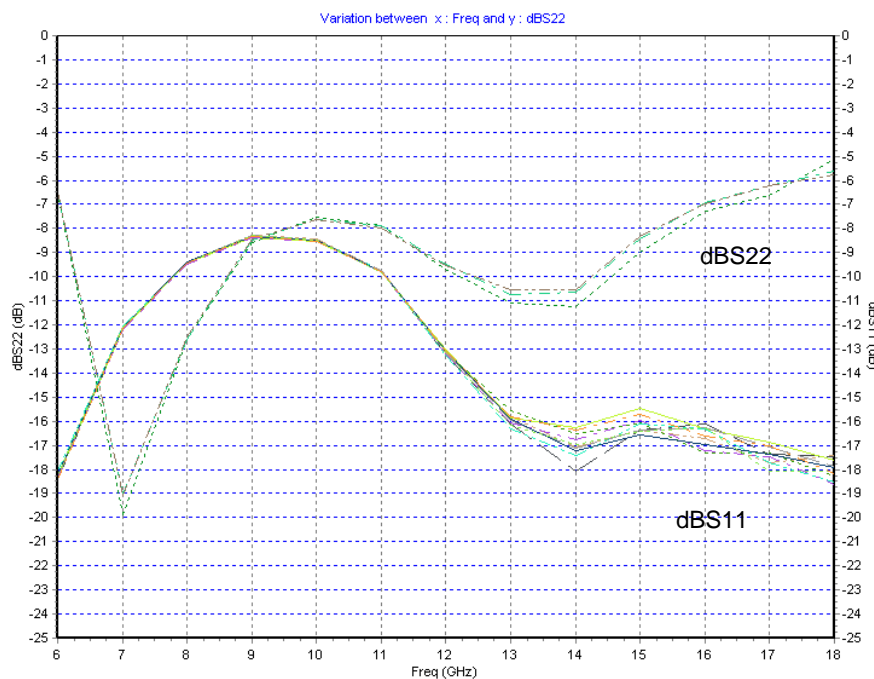

Input and Output Return losses

On Wafer Measurements (one channel):

Tamb=25°C, Vd=8V, Id (Quiescent) = 0.6A, Pin=11dBm, pulsed mode:

Preliminary

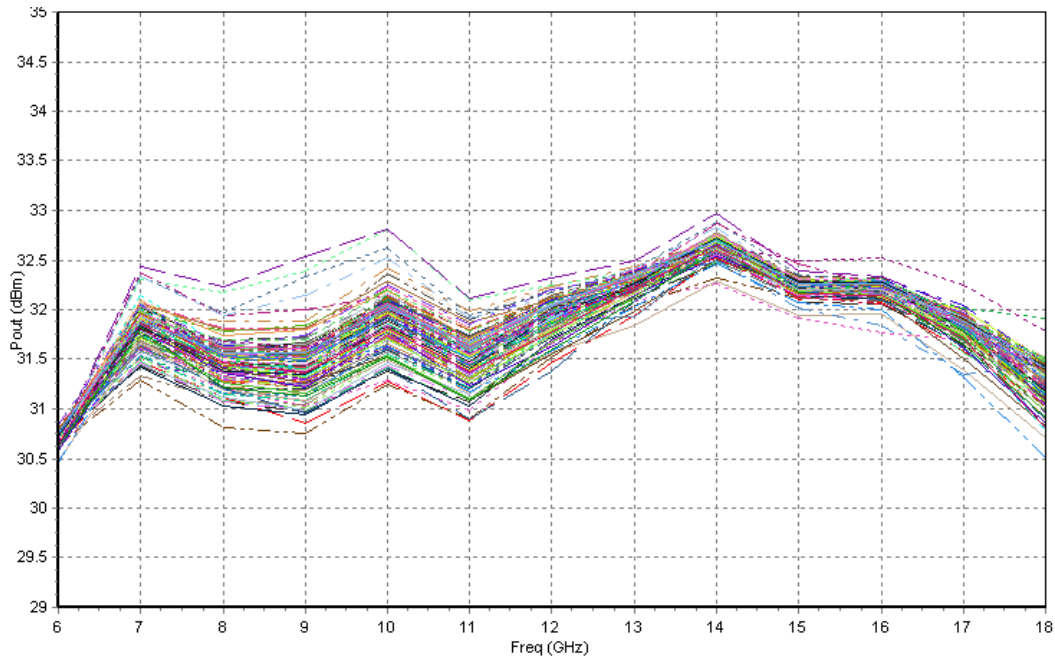

Output Power versus Frequency

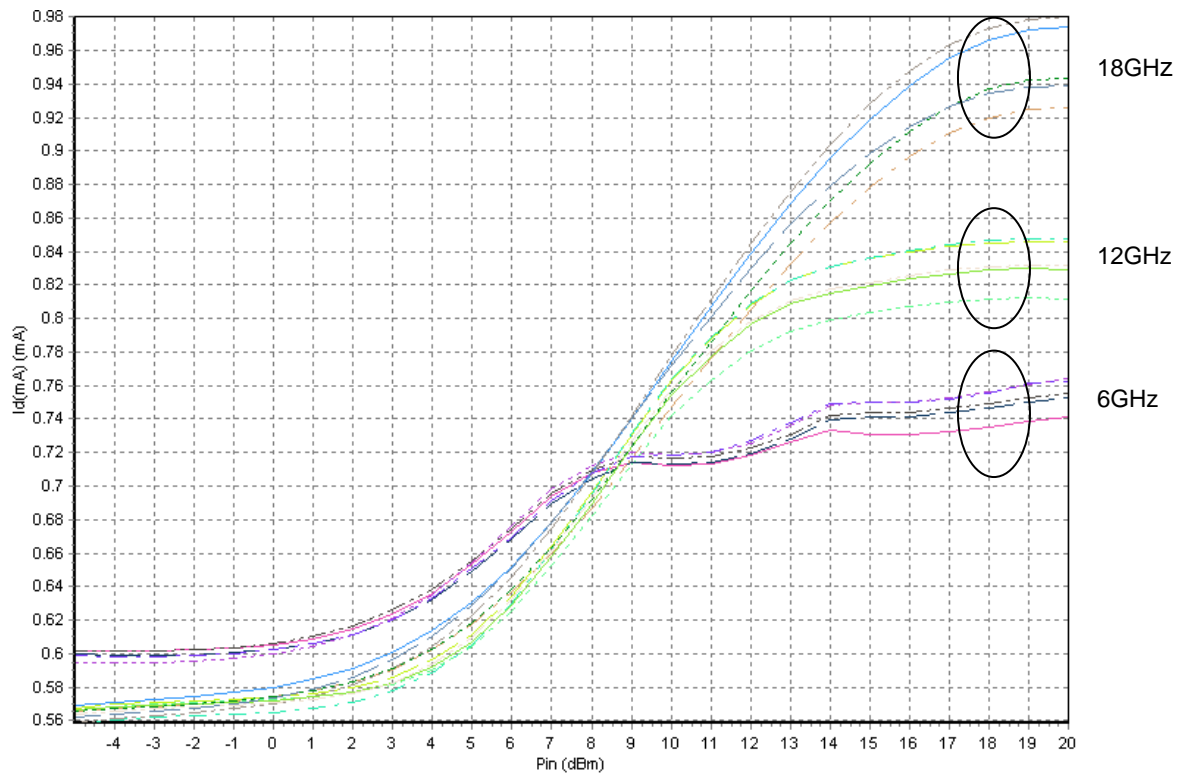

Id versus Pin

In test jig Measurements (one channel):
Vd=8V, Id (Quiescent) = 0.6A, S parameters, CW mode:

Preliminary

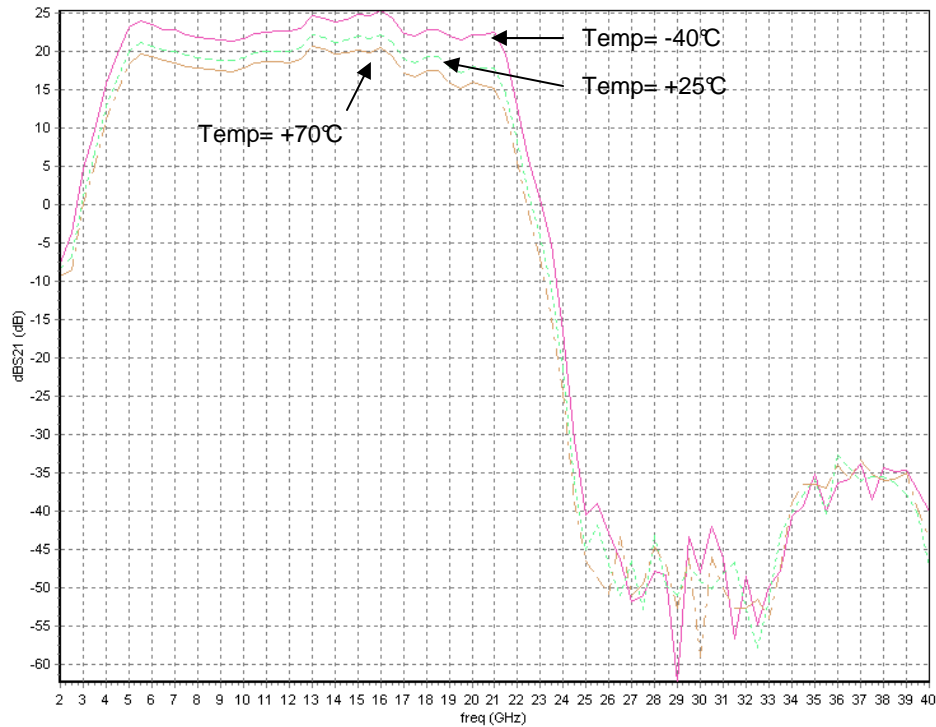

Gain versus Frequency and Temperature (-40°C, +25°C and +70°C)

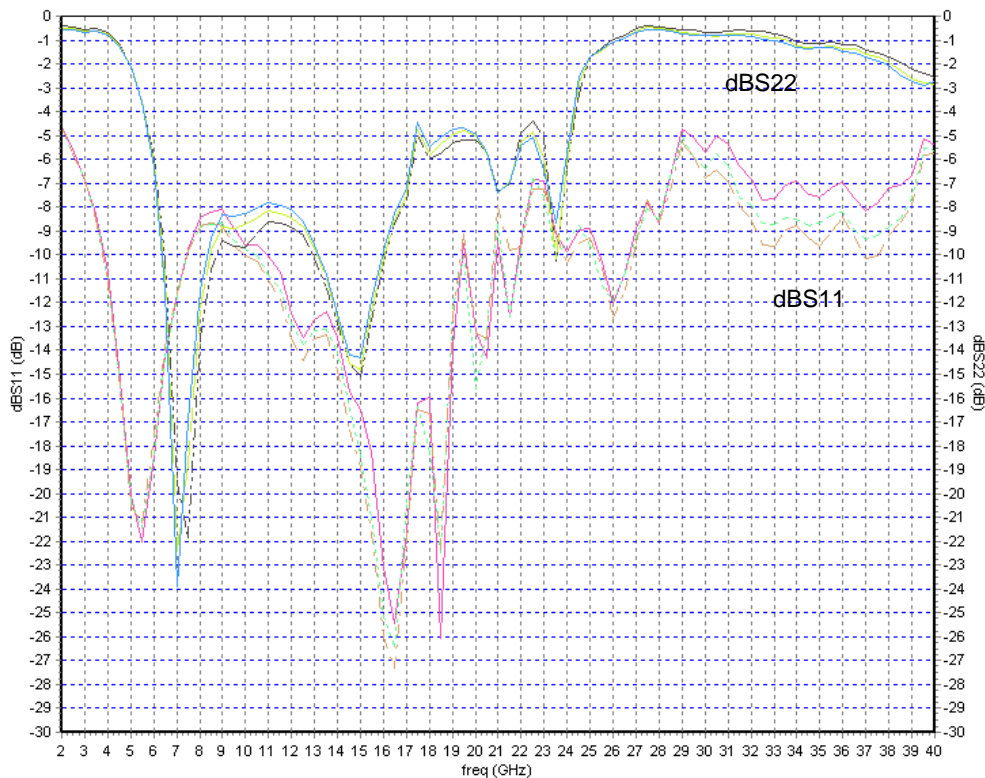

Input and Output Return losses versus Frequency and Temperature

Preliminary

In test jig Measurements (one channel):

Vd=8V, Id (Quiescent) = 0.6A, Power measurements, CW mode

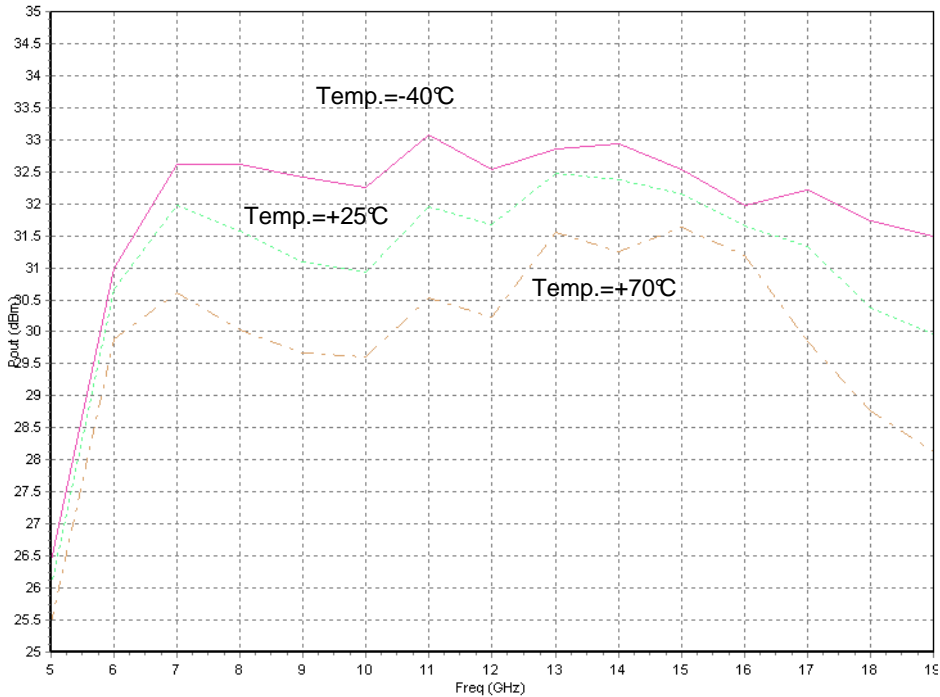

Output power versus Frequency and Temperature (Pin=+12dBm)

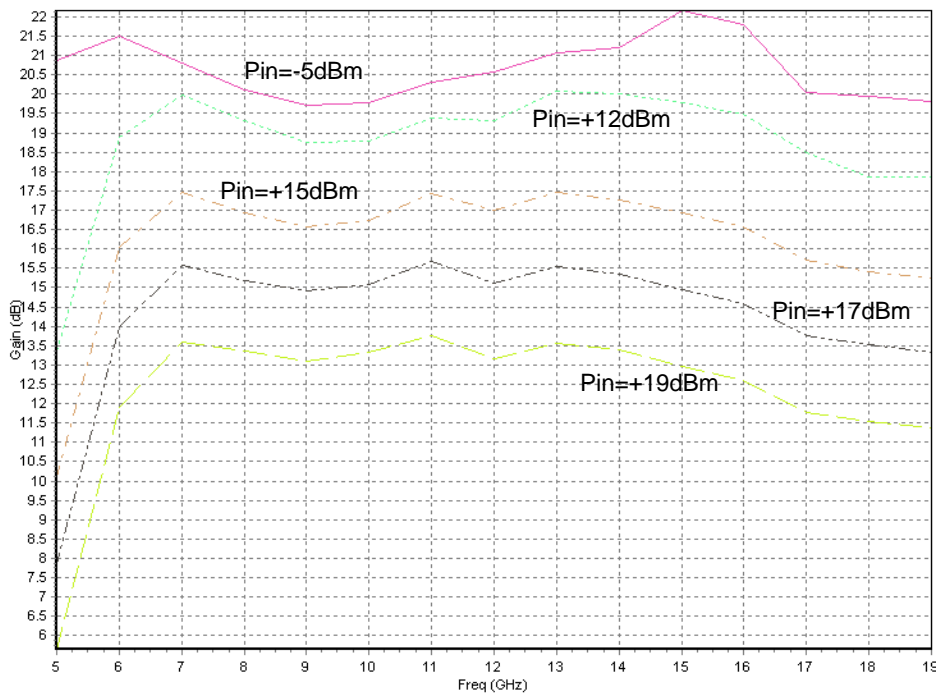

Gain versus Frequency and Input power (Temp.=+25°C)

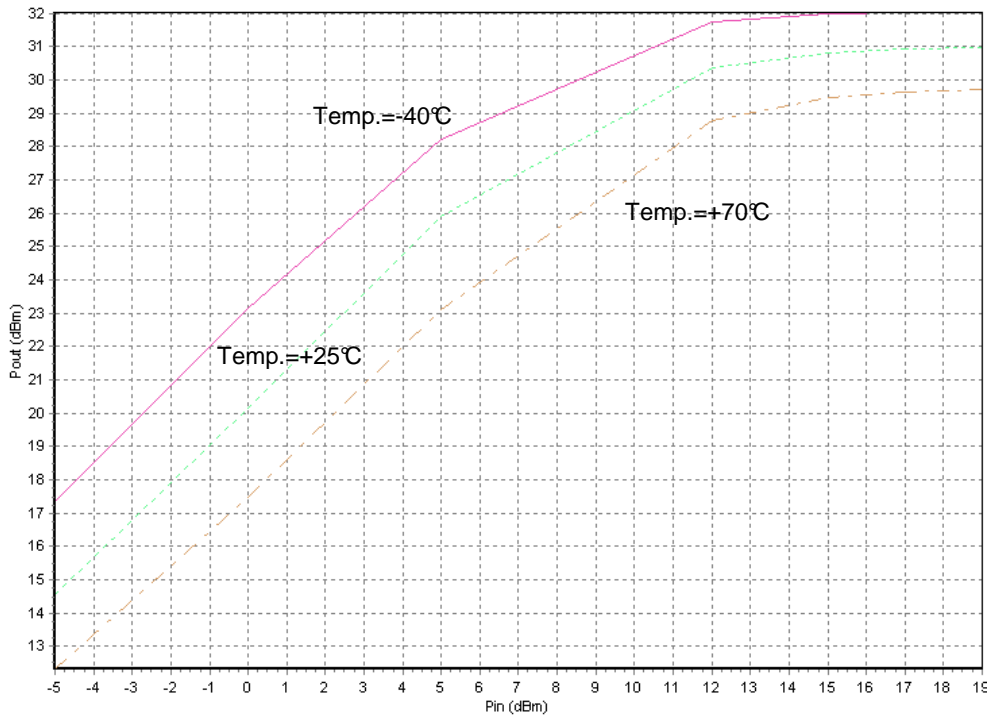

Output power versus Frequency and Temperature (Freq=18GHz)

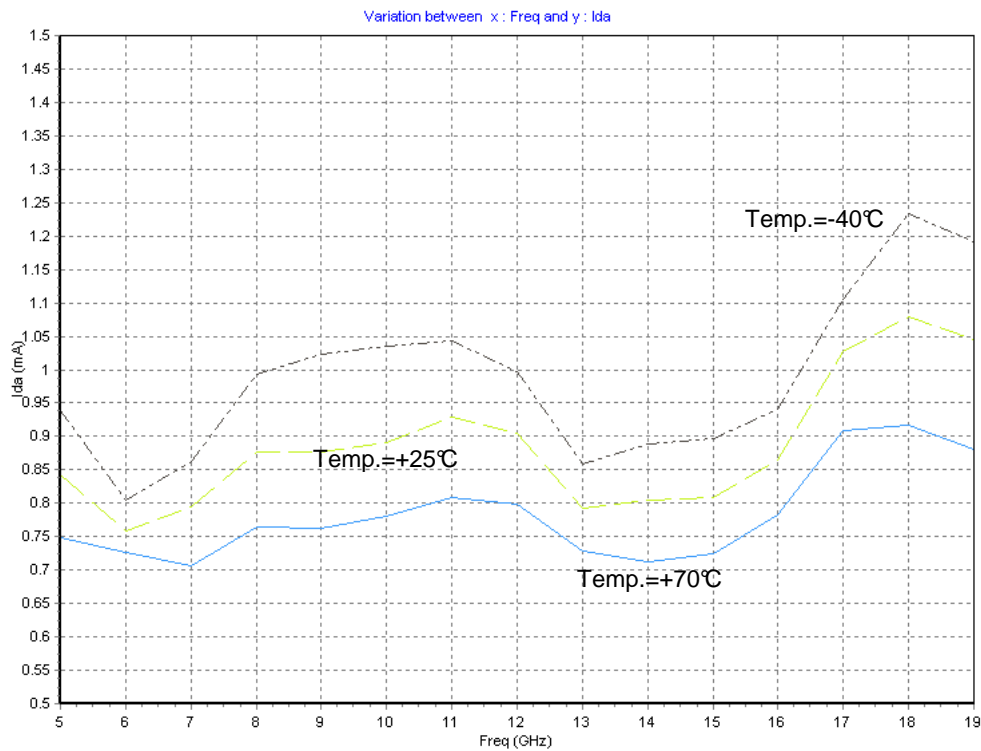

Id current versus Frequency and Temperature (Pin=+17dBm)

Chip Mechanical Data and Pin references

Preliminary

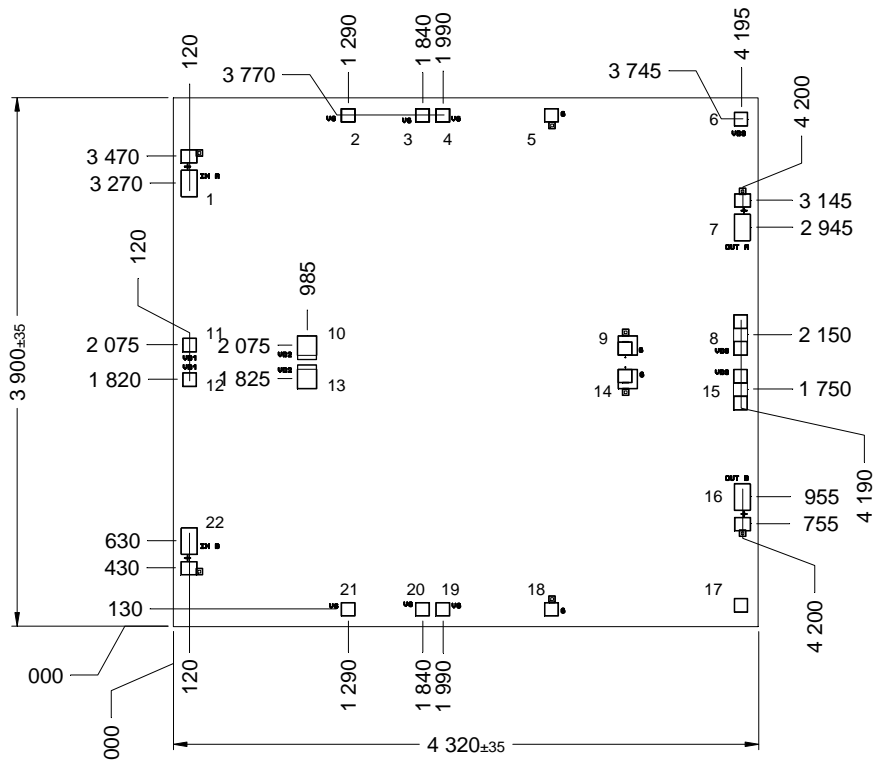

UNITS : μm
Tol : $\pm 35\mu\text{m}$

Chip thickness = $70\mu\text{m} \pm 10\mu\text{m}$
 HF pads (1, 7, 16, 22) = 118×196
 DC pads = 96×96

Pin number	Pin name	Description
1, 22	IN	Input RF port
2, 3, 4, 19, 20, 21	VG	Negative supply voltage
5, 9, 14, 18	GND	Ground (NC)
6, 8, 10, 11, 12, 13, 15, 17	VD	Positive supply voltage
7, 16	OUT	Output RF port

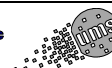

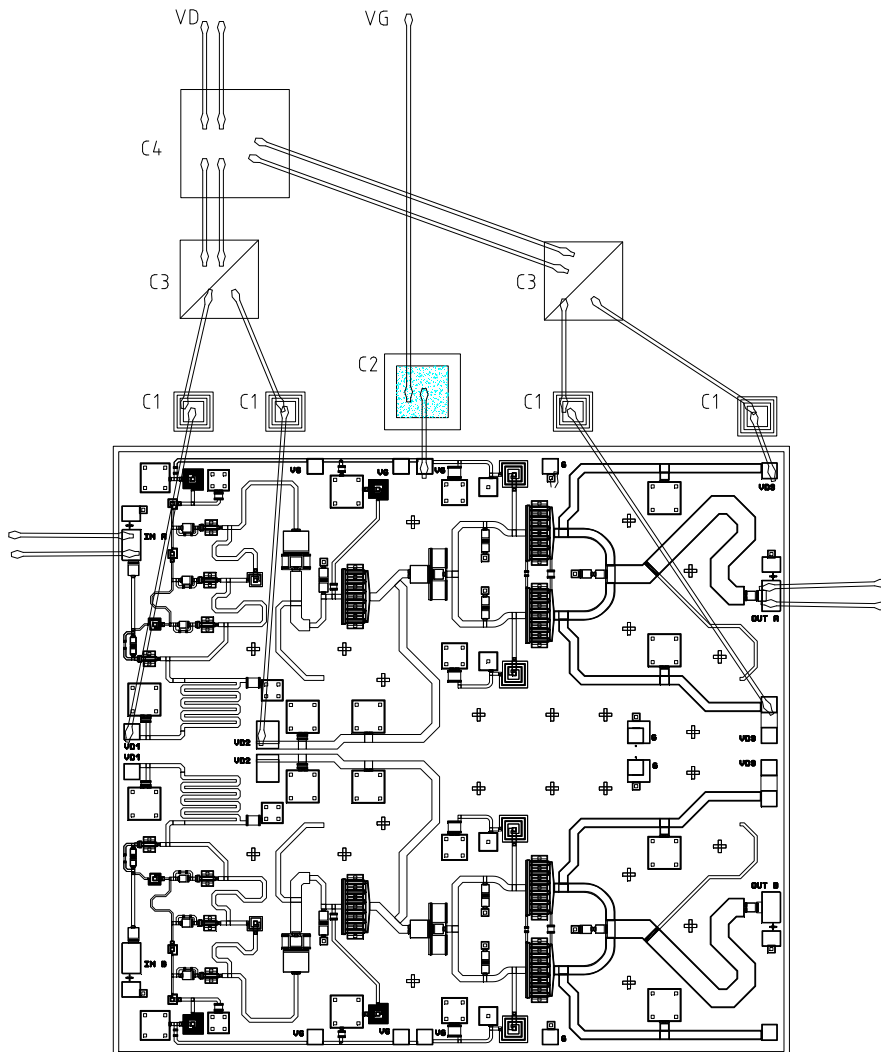

Assembly recommendations (one channel)

For thermal and electrical considerations, the chip should be brazed on a metal base plate. The RF and DC connections should be done according to the following table:

Port	Connection	External capacitor
IN (1, 22) OUT (7, 16)	Inductance (L_{bonding}) = 0.3nH	
VD (6, 8, 10, 11, 12, 13, 15, 17)	Inductance \leq 1nH	C1 ~ 22pF C3 ~ 1nF C4 ~ 100nF
VG (2, 3, 4, 19, 20, 21)	Inductance \leq 1nH	C2 ~ 120pF

Preliminary

Ordering Information

Chip form : CHA6517-99F/00

Information furnished is believed to be accurate and reliable. However **United Monolithic Semiconductors S.A.S.** assumes no responsibility for the consequences of use of such information nor for any infringement of patents or other rights of third parties which may result from its use. No license is granted by implication or otherwise under any patent or patent rights of **United Monolithic Semiconductors S.A.S.** Specifications mentioned in this publication are subject to change without notice. This publication supersedes and replaces all information previously supplied. **United Monolithic Semiconductors S.A.S.** products are not authorised for use as critical components in life support devices or systems without express written approval from **United Monolithic Semiconductors S.A.S**