

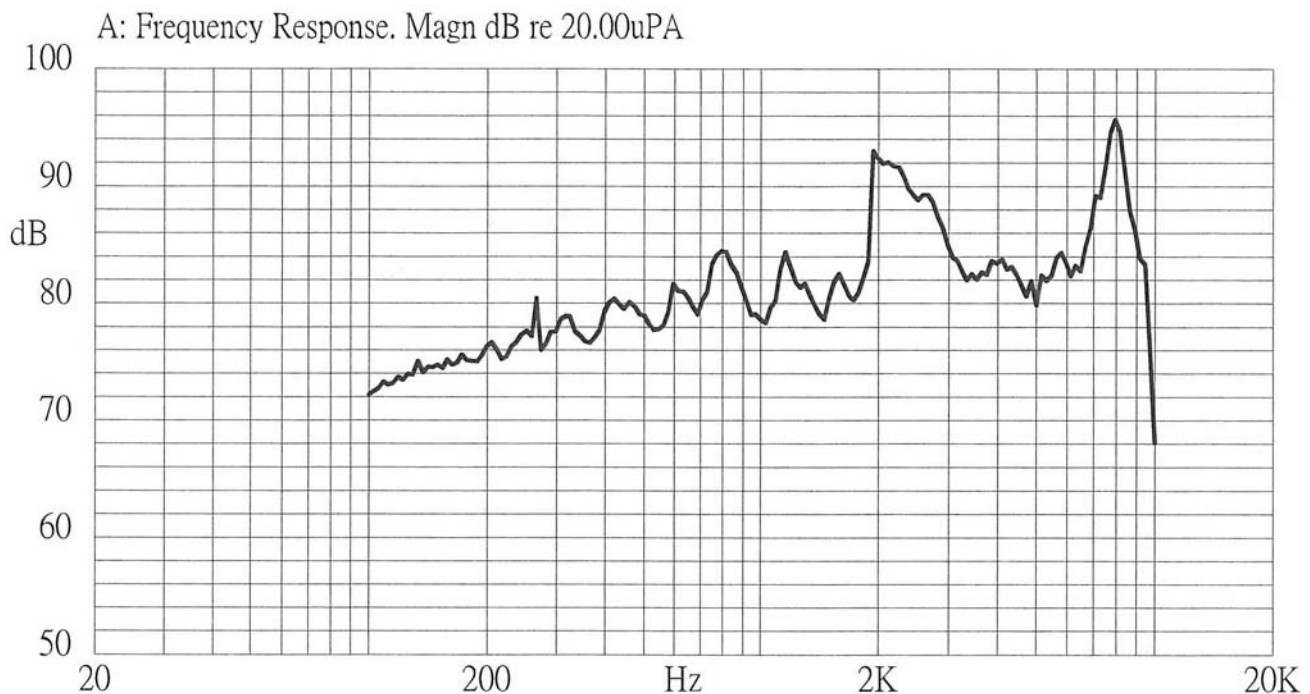
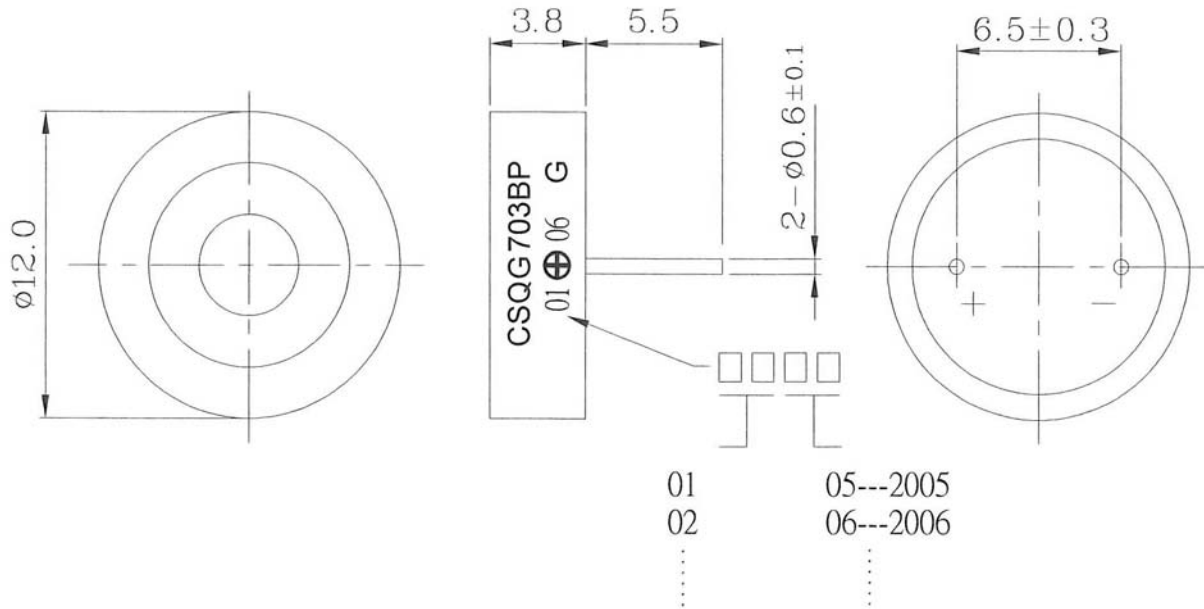
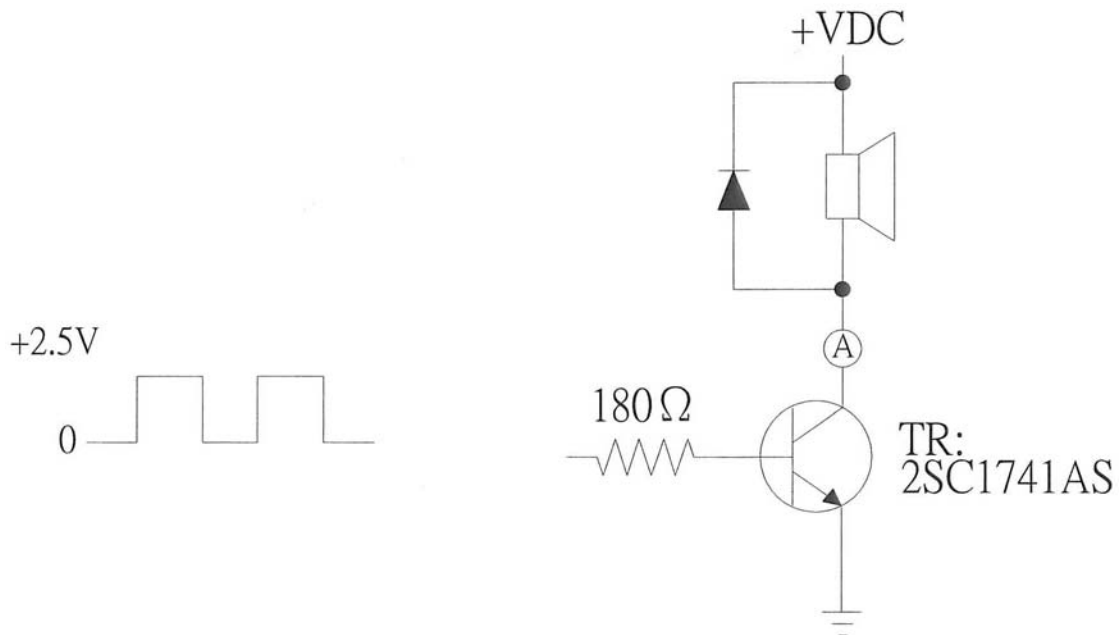

Specifications

Rated voltage	3.0 Vo-p	
Operating voltage	2.0 ~ 4.0 Vo-p	
Mean current	90 mA max.	
Coil resistance	15.0 ±2.0 Ω	Applying rated voltage, 2000 Hz square wave, ½ duty
Sound output	Min. 85 (Typical 90) dBA	Distance at 5cm (A-weight free air). Applying rated voltage of 2000 Hz, square wave, ½ duty.
Rated frequency	2,000 Hz	
Operating temperature	-30 ~ +70° C	
Storage temperature	-40 ~ +85° C	
Dimensions	ø12.0 x H3.8 mm	See attached drawing
Weight	1.0 g	
Material	PPO (Black)	
Terminal	Pin type (Au Plating)	See attached drawing
RoHS	yes	

Frequency Response Curve

Appearance Drawing

 Tolerance: ± 0.5

Measurement Method

Mechanical Characteristics

Item	Test Condition	Evaluation Standard
Solderability	Lead terminals are immersed in rosin for 5 seconds and then immersed in a solder bath of $+270 \pm 5^{\circ}\text{C}$ for 3 ± 1 seconds.	90% min. lead terminals must be covered with fresh solder. (Except the edge of the terminal.)
Soldering Heat Resistance	Lead terminals are immersed up to 1.5mm from buzzer's body in solder bath of $270 \pm 5^{\circ}\text{C}$ for 3 ± 1 seconds.	No in interference in operation.
Terminal Mechanical Strength	Lead pads shall be soldered onto the pc board and the force of 9.8 N (1.0 kg) shall be applied behind the part for 10 seconds.	No damage or cutting off.
Vibration	The buzzer will be measured after applying a vibration amplitude of 1.5 mm with 10 to 55 Hz band of vibration frequency to each of the 3 perpendicular directions for 2 hours.	After the test, the part shall meet specifications without any damage to the appearance and the SPL should be within ± 10 dBA of the initial SPL.
Drop Test	The part is to be dropped from a height of 75 cm onto a 40 mm thick wooden board 3 times in 3 axis (X, Y, Z) for a total of 9 drops.	

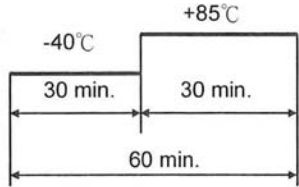
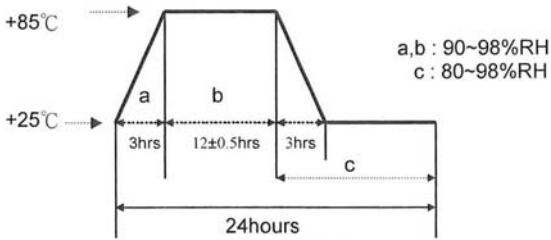
Environment Test

Item	Test Condition	Evaluation Standard
High temp. test	The part will be subjected to $+85^{\circ}\text{C}$ for 96 hours.	
Low temp. test	The part will be subjected to -40°C for 96 hours	
Thermal shock	The part will be subjected to 10 cycles. One cycle will consist of: <div style="text-align: center;">  </div>	
Temp./Humidity cycle	The part should be subjected to 10 cycles. One cycle will last for 24 hours and consist of: <div style="text-align: center;">  </div>	The buzzer will be measured after being placed at $+25^{\circ}\text{C}$ for 4 hours. There should be no degradation to the appearance or performance. The SPL should be within ± 10 dB compared to the initial measurements.



Reliability Test

Item	Test Condition	Evaluation Standard
Operating (Life Test)	1. Continuous life test: The part will be subjected to 72 hours at +55°C with 3.0 V, 2000 Hz applied. 2. Intermittent life test: A duty cycle of 1 minute on, 1 minute off, a minimum of 10,000 times at room temp (+25±10°C) with 3.0 V, 2000 Hz applied.	After the test, the part shall meet specifications without any damage to the appearance or performance. After 4 hours at +25°C, the SPL should be within ±10 dBA of the initial SPL.

Test Conditions

Standard Test Condition	a) Temperature: +5 ~ +35°C	b) Humidity: 45 - 85%	c) Pressure: 860 - 1060 mbar
Judgement Test Condition	a) Temperature: +25±2°C	b) Humidity: 60 - 70%	c) Pressure: 860 - 1060 mbar



Packaging

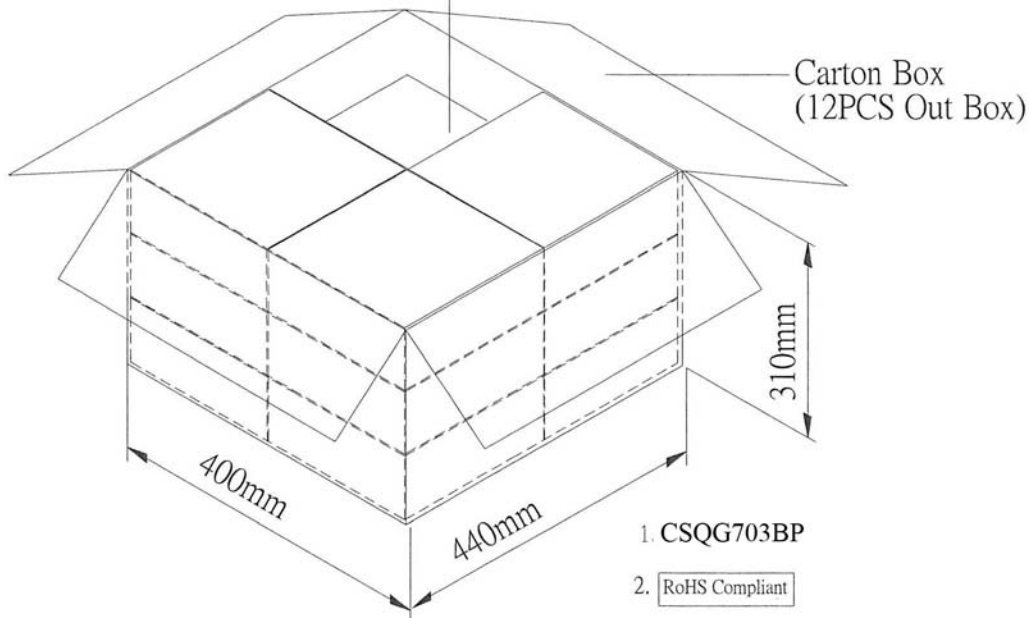
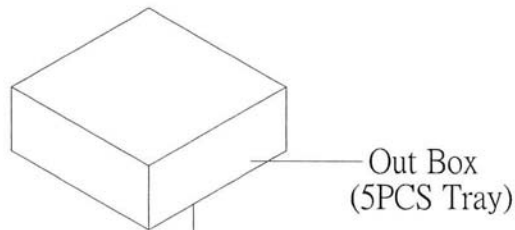
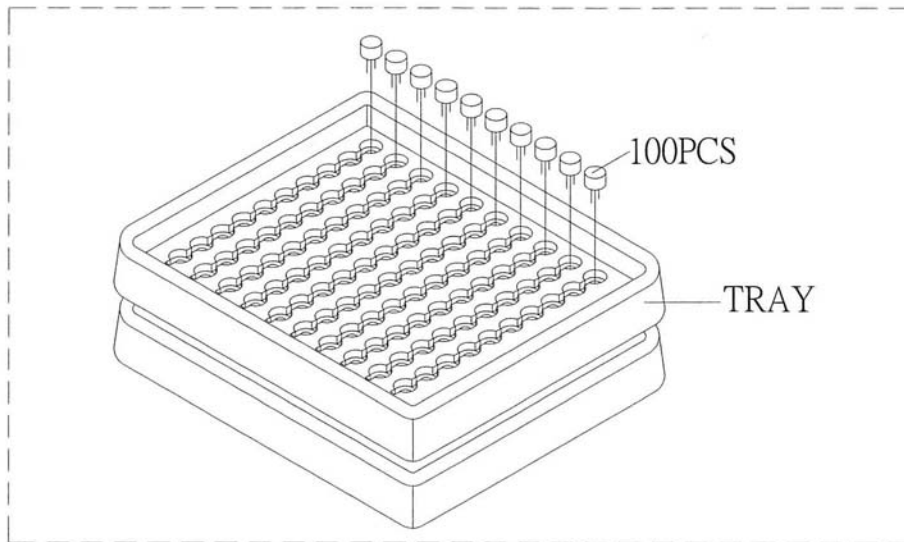

Tray	184mmx184mmx23mm	1x100PCS=100PCS
Out Box	200mmx190mmx100mm	5LAYERx100PCS=500PCS
Carton Box	440mmx400mmx310mm	500PCSx12=6000PCS