

## Aluminum Capacitors Axial Miniature, Long-Life

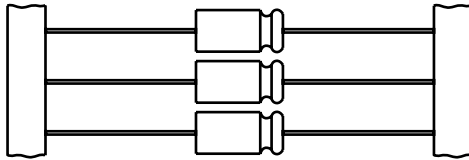

Fig.1 Component outlines



### FEATURES

- Polarized aluminum electrolytic capacitors, non-solid electrolyte
- Axial leads, cylindrical aluminum case, insulated with a blue sleeve (case  $\varnothing$  6.3 x 12.7 and 7.7 x 12.7 mm are moulded with flame retardant plastic material)
- Mounting ring version not available in insulated form
- Taped versions up to case  $\varnothing$  15 x 30 mm available for automatic insertion
- Charge and discharge proof
- Long useful life: 2000 to 10 000 hours at 105 °C, high reliability
- High ripple current capability
- Miniaturized, high CV-product per unit volume
- Lead (Pb)-free versions are RoHS compliant

**RoHS  
COMPLIANT**

### APPLICATIONS

- Industrial, automotive, EDP and telecommunication
- Smoothing, filtering, buffering in SMPS; coupling, decoupling, timing
- Portable and mobile equipment (small size, low mass)
- Stand-by applications
- Low mounting height boards, vibration and shock resistant

### MARKING

The capacitors are marked (where possible) with the following information:

- Rated capacitance (in  $\mu\text{F}$ )
- Tolerance on rated capacitance, code letter in accordance with IEC 60062 (M for  $\pm 20\%$ )
- Rated voltage (in V)
- Upper category temperature (105 °C)
- Date code, in accordance with IEC 60062
- Code for factory of origin
- Name of manufacturer
- Band to indicate the negative terminal
- '+' sign to identify the positive terminal (not for case sizes  $L < 18$  mm)
- Series number (138)

QUICK REFERENCE DATA		
DESCRIPTION	VALUE	
Nominal case sizes ( $\varnothing$ D x L in mm)	6.3 x 12.7 to 10 x 25	10 x 30 to 21 x 38
Rated capacitance range, $C_R$	1.0 to 15 000 $\mu\text{F}$	
Tolerance on $C_R$	$\pm 20\%$	
Rated voltage range, $U_R$	6.3 to 100 V	
Category temperature range	- 40 to + 105 °C	
Endurance test at 105 °C	1000 hours	5000 hours
Useful life at 105 °C	2000 hours	10 000 hours
Useful life at 40 °C, $I_R$ applied	1.3 x $I_R$ applied: 200 000 hours	1.8 x $I_R$ applied: 500 000 hours
Shelf life at 0 V, 105 °C	500 hours	500 hours
Based on sectional specification	IEC 60384-4/EN130 300	
Climatic category IEC 60068	40/105/56	

SELECTION CHART FOR $C_R$ , $U_R$ AND RELEVANT NOMINAL CASE SIZES ( $\varnothing D \times L$ in mm)								
$C_R$ ( $\mu F$ )	$U_R$ (V)							
	6.3	10	16	25	40	50	63	100
1.0	-	-	-	-	-	-	-	6.3 x 12.7
2.2	-	-	-	-	-	-	-	6.3 x 12.7
4.7	-	-	-	-	-	-	6.3 x 12.7	7.7 x 12.7
10	-	-	-	6.3 x 12.7	-	6.3 x 12.7	7.7 x 12.7	6.5 x 18
22	-	-	6.3 x 12.7	6.3 x 12.7	-	7.7 x 12.7	6.5 x 18	8 x 18
33	-	-	-	6.3 x 12.7	7.7 x 12.7	-	-	-
47	-	-	6.3 x 12.7	7.7 x 12.7	6.5 x 18	-	8 x 18	10 x 25
68	-	-	-	-	-	-	-	10 x 30
100	6.3 x 12.7	-	7.7 x 12.7	6.5 x 18	8 x 18	10 x 18	10 x 25	12.5 x 30
150	-	7.7 x 12.7	-	-	-	-	10 x 30	15 x 30
220	7.7 x 12.7	6.5 x 18	8 x 18	10 x 18	10 x 25	-	12.5 x 30	15 x 30
330	-	-	-	-	10 x 30	-	12.5 x 30	18 x 30
470	6.5 x 18	8 x 18	10 x 18	10 x 25	12.5 x 30	-	15 x 30	18 x 38
680	-	-	-	10 x 30	12.5 x 30	-	18 x 30	21 x 38
1000	10 x 18	10 x 25	10 x 30	12.5 x 30	15 x 30	-	18 x 38	-
1500	-	10 x 30	12.5 x 30	15 x 30	18 x 30	-	21 x 38	-
2200	10 x 25	12.5 x 30	15 x 30	18 x 30	18 x 38	-	-	-
3300	-	15 x 30	18 x 30	18 x 38	21 x 38	-	-	-
4700	-	18 x 30	18 x 30	18 x 38	-	-	-	-
6800	-	18 x 38	18 x 38	21 x 38	-	-	-	-
10 000	-	18 x 38	21 x 38	-	-	-	-	-
15 000	-	21 x 38	-	-	-	-	-	-

**DIMENSIONS** in millimeters **AND AVAILABLE FORMS**

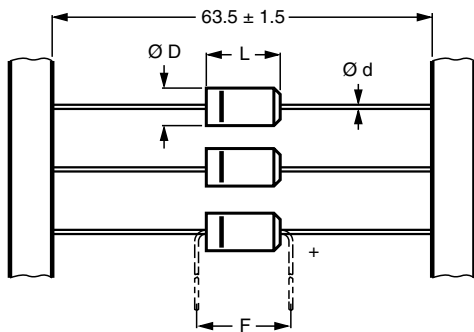

**Form BR:** Taped on reel  
**Form BA:** Taped in box (ammopack)  
 case  $\varnothing D \times L = 6.3 \times 12.7$  to  $7.7 \times 12.7$  mm

Fig.2 Forms BA and BR

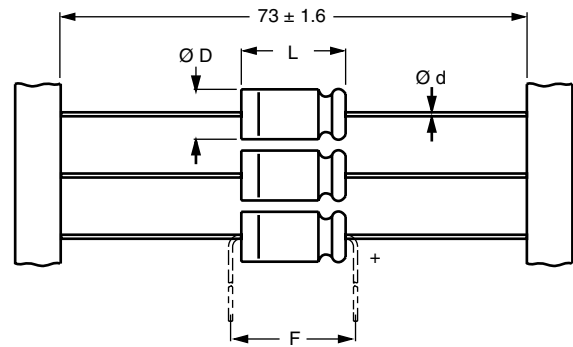

**Form BR:** Taped on reel  
 case  $\varnothing D \times L = 6.5 \times 18$  to  $15 \times 30$  mm  
**Form BA:** Taped in box (ammopack)  
 case  $\varnothing D \times L = 6.5 \times 18$  to  $10 \times 25$  mm

Fig.3 Forms BA and BR

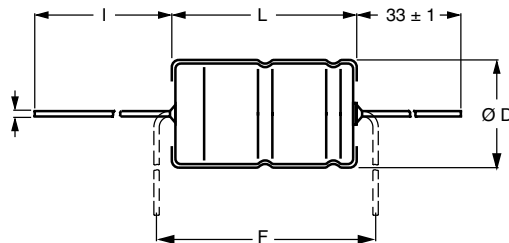

**Form AA:** Axial in box  
 case  $\varnothing D \times L = 10 \times 30$  to  $21 \times 38$  mm

Fig.4 Form AA

Table 1

<b>AXIAL; DIMENSIONS</b> in millimeters, <b>MASS AND PACKAGING QUANTITIES</b>										
NOMINAL CASE SIZE Ø D x L (mm)	CASE CODE	AXIAL: FORM AA, BA, and BR					MASS (g)	PACKAGING QUANTITIES		
		Ø d	l	Ø D <sub>max.</sub>	L <sub>max.</sub>	F <sub>min.</sub>		FORM AA	FORM BA	FORM BR
6.3 x 12.7	(2)	0.6	-	6.5	12.9	17.5	≈ 1.1	-	1000	1000
7.7 x 12.7	(3)	0.6	-	7.9	12.9	17.5	≈ 1.3	-	500	500
6.5 x 18	4	0.8	-	6.9	18.5	25	≈ 1.3	-	1000	1000
8 x 18	5	0.8	-	8.5	18.5	25	≈ 1.7	-	500	500
10 x 18	6	0.8	-	10.5	18.5	25	≈ 2.5	-	500	500
10 x 25	7	0.8	-	10.5	25.5	30	≈ 3.3	-	500	500
10 x 30	00	0.8	55 ± 1	10.5	30.5	35	≈ 4.8	340	-	500
12.5 x 30	01	0.8	55 ± 1	13.0	30.5	35	≈ 7.4	260	-	400
15 x 30	02	0.8	55 ± 1	15.5	30.5	35	≈ 11.7	200	-	250
18 x 30	03	0.8	55 ± 1	18.5	30.5	35	≈ 12.9	120	-	-
18 x 38	04	0.8	34 ± 1	18.5	39.5	44	≈ 19.0	125	-	-
21 x 38	05	0.8	34 ± 1	21.5	39.5	44	≈ 24.0	100	-	-

**Note**

Detailed tape dimensions see section 'PACKAGING'.

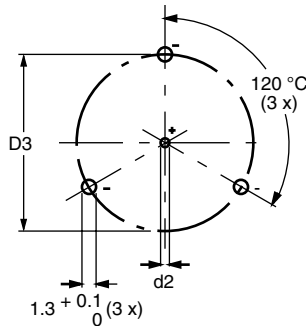

Mounting holes

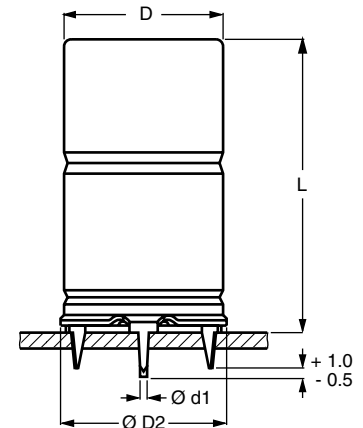
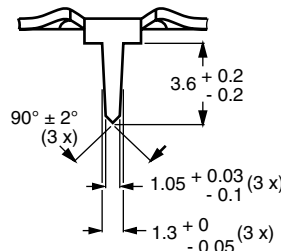

Case Ø D x L = 15 x 30 to 21 x 38 mm

Case not insulated (insulation on request)

Especially for applications with severe shocks and vibrations

 Fig.5 Mounting hole diagram and outline; **Form MR:** With mounting ring and pins

Table 2

<b>MOUNTING RING; DIMENSIONS</b> in millimeters, <b>MASS AND PACKAGING QUANTITIES</b>									
NOMINAL CASE SIZE Ø D x L	CASE CODE	MOUNTING RING: FORM MR						MASS (g)	PACKAGING QUANTITIES
		Ø d1	Ø d2	D <sub>max.</sub>	Ø D2 <sub>max.</sub>	D3	L <sub>max.</sub>		
15 x 30	02	0.8	1.0 + 0.4	15.5	17.5	16.5 ± 0.2	33	≈ 11.7	200
18 x 30	03	0.8	1.0 + 0.4	18.5	19.5	18.5 ± 0.2	33	≈ 12.9	240
18 x 38	04	0.8	1.0 + 0.4	18.5	19.5	18.5 ± 0.2	42	≈ 19.0	100
21 x 38	05	0.8	1.0 + 0.4	21.5	22.5	21.5 ± 0.2	42	≈ 24.0	100



ELECTRICAL DATA	
SYMBOL	DESCRIPTION
$C_R$	rated capacitance at 100 Hz, tolerance $\pm 20\%$
$I_R$	rated RMS ripple current at 100 Hz, 105 °C
$I_{L5}$	max. leakage current after 5 minutes at $U_R$
$\tan \delta$	max. dissipation factor at 100 Hz
ESR	equivalent series resistance at 100 Hz (calculated from $\tan \delta_{max}$ and $C_R$ )
Z	max. impedance at 10 kHz or 100 kHz

**Note**

Unless otherwise specified, all electrical values in Table 3 apply at  $T_{amb} = 20\text{ °C}$ ,  $P = 86$  to 106 kPa, RH = 45 to 75 %.

Table 3

ELECTRICAL DATA AND ORDERING INFORMATION													
$U_R$ (V)	$C_R$ 100 Hz ( $\mu\text{F}$ )	NOMINAL CASE SIZE $\varnothing D \times L$ (mm)	$I_R$ 100 Hz 105 °C (mA)	$I_{L5}$ 5 min ( $\mu\text{A}$ )	$\tan \delta$ 100 Hz	ESR 100 Hz ( $\Omega$ )	Z 10 kHz ( $\Omega$ )	Z 100 kHz ( $\Omega$ )	ORDERING CODE MAL2138.....				
									IN BOX FORM AA	TAPED ON REEL FORM BR	TAPED IN BOX FORM BA	MOUNTING RING FORM MR	
6.3	100	6.3 x 12.7	99	5.3	0.24	3.8	3.0	1.8	-	23101E3	33101E3	-	
	220	7.7 x 12.7	160	6.8	0.24	1.7	1.4	0.95	-	23221E3	33221E3	-	
	470	6.5 x 18	250	9.9	0.24	0.81	0.64	0.5	-	23471E3	33471E3	-	
	1000	10 x 18	430	17	0.24	0.38	0.30	0.24	-	23102E3	33102E3	-	
	2200	10 x 25	640	32	0.29	0.21	0.18	0.15	-	23222E3	33222E3	-	
10	150	7.7 x 12.7	140	7.0	0.2	2.1	1.3	0.95	-	24151E3	34151E3	-	
	220	6.5 x 18	190	8.4	0.2	1.4	0.91	0.5	-	24221E3	34221E3	-	
	470	8 x 18	300	13	0.2	0.68	0.43	0.35	-	24471E3	34471E3	-	
	1000	10 x 25	520	24	0.2	0.32	0.20	0.16	-	24102E3	34102E3	-	
	1500	10 x 30	670	34	0.28	0.32	0.26	0.26	14152E3	24152E3	-	-	
	2200	12.5 x 30	890	48	0.29	0.22	0.19	0.19	14222E3	24222E3	-	-	
	3300	15 x 30	1140	70	0.30	0.16	0.13	0.15	14332E3	24332E3	-	44332E3	
	4700	18 x 30	1450	98	0.33	0.12	0.11	0.13	14472E3	-	-	44472E3	
	6800	18 x 38	1880	140	0.34	0.085	0.074	0.11	14682E3	-	-	44682E3	
	10 000	18 x 38	1980	200	0.41	0.070	0.062	0.10	14103E3	-	-	44103E3	
15 000	21 x 38	2200	300	0.55	0.063	0.058	0.099	14153E3	-	-	44153E3		
16	22	6.3 x 12.7	58	4.7	0.12	8.7	7.3	2.7	-	25229E3	35229E3	-	
	47	6.3 x 12.7	83	5.5	0.16	5.4	3.4	1.9	-	25479E3	35479E3	-	
	100	7.7 x 12.7	130	7.2	0.16	2.5	1.6	1.0	-	25101E3	35101E3	-	
	220	8 x 18	230	11	0.16	1.2	0.73	0.35	-	25221E3	35221E3	-	
	470	10 x 18	360	19	0.16	0.54	0.34	0.25	-	25471E3	35471E3	-	
	1000	10 x 30	630	36	0.20	0.34	0.27	0.26	15102E3	25102E3	-	-	
	1500	12.5 x 30	860	52	0.20	0.23	0.19	0.19	15152E3	25152E3	-	-	
	2200	15 x 30	1090	74	0.21	0.17	0.14	0.15	15222E3	25222E3	-	45222E3	
	3300	18 x 30	1420	110	0.24	0.12	0.10	0.13	15332E3	-	-	45332E3	
	4700	18 x 30	1480	150	0.28	0.10	0.090	0.12	15472E3	-	-	45472E3	
	6800	18 x 38	1930	220	0.28	0.072	0.062	0.10	15682E3	-	-	45682E3	
	10 000	21 x 38	2100	320	0.38	0.065	0.057	0.098	15103E3	-	-	45103E3	
25	10	6.3 x 12.7	46	4.5	0.09	14	12	2.8	-	26109E3	36109E3	-	
	22	6.3 x 12.7	61	5.1	0.14	10	5.5	2.5	-	26229E3	36229E3	-	
	33	6.3 x 12.7	74	5.7	0.14	6.8	3.6	1.9	-	26339E3	36339E3	-	
	47	7.7 x 12.7	96	6.4	0.14	4.7	2.6	1.0	-	26479E3	36479E3	-	

**ORDERING EXAMPLE**

Electrolytic capacitor 138 series

470  $\mu\text{F}/10\text{ V}$ ;  $\pm 20\%$

Nominal case size:  $\varnothing 8 \times 18\text{ mm}$ ; Form BA

Ordering code: MAL213834471E3

Former 12 NC: 2222 138 34471



Aluminum Capacitors  
Axial Miniature, Long-Life

Vishay BCcomponents

ELECTRICAL DATA AND ORDERING INFORMATION													
U <sub>R</sub> (V)	C <sub>R</sub> 100 HZ (μF)	NOMINAL CASE SIZE Ø D x L (mm)	I <sub>R</sub> 100 Hz 105 °C (mA)	I <sub>L5</sub> 5 min (μA)	tan δ 100 Hz	ESR 100 Hz (Ω)	Z 10 kHz (Ω)	Z 100 kHz (Ω)	ORDERING CODE MAL2138.....				
									IN BOX FORM AA	TAPED ON REEL FORM BR	TAPED IN BOX FORM BA	MOUNTING RING FORM MR	
25	100	6.5 x 18	160	9.0	0.13	2.1	1.2	0.55	-	26101E3	36101E3	-	
	220	10 x 18	270	15	0.13	0.94	0.55	0.27	-	26221E3	36221E3	-	
	470	10 x 25	440	28	0.13	0.44	0.26	0.17	-	26471E3	36471E3	-	
	680	10 x 30	580	38	0.14	0.36	0.26	0.25	16681E3	26681E3	-	-	
	1000	12.5 x 30	790	54	0.15	0.25	0.18	0.19	16102E3	26102E3	-	-	
	1500	15 x 30	1020	79	0.15	0.17	0.13	0.15	16152E3	26152E3	-	46152E3	
	2200	18 x 30	1320	110	0.17	0.13	0.10	0.13	16222E3	-	-	46222E3	
	3300	18 x 38	1720	170	0.17	0.090	0.071	0.11	16332E3	-	-	46332E3	
	4700	18 x 38	1840	240	0.21	0.076	0.063	0.10	16472E3	-	-	46472E3	
6800	21 x 38	2100	340	0.27	0.068	0.058	0.099	16682E3	-	-	46682E3		
40	33	7.7 x 12.7	91	6.6	0.11	5.3	2.7	1.0	-	27339E3	37339E3	-	
	47	6.5 x 18	120	7.8	0.10	3.4	1.9	0.65	-	27479E3	37479E3	-	
	100	8 x 18	180	12	0.10	1.6	0.9	0.40	-	27101E3	37101E3	-	
	220	10 x 25	350	22	0.10	0.72	0.41	0.20	-	27221E3	37221E3	-	
	330	10 x 30	490	30	0.09	0.47	0.32	0.30	17331E3	27331E3	-	-	
	470	12.5 x 30	650	42	0.09	0.34	0.23	0.22	17471E3	27471E3	-	-	
	680	12.5 x 30	750	58	0.10	0.25	0.18	0.18	17681E3	27681E3	-	-	
	1000	15 x 30	970	84	0.10	0.17	0.12	0.14	17102E3	27102E3	-	47102E3	
	1500	18 x 30	1250	120	0.12	0.13	0.098	0.12	17152E3	-	-	47152E3	
2200	18 x 38	1640	180	0.12	0.093	0.069	0.10	17222E3	-	-	47222E3		
3300	21 x 38	1810	270	0.15	0.079	0.061	0.10	17332E3	-	-	47332E3		
50	10	6.3 x 12.7	51	5.0	0.09	14	7	2.7	-	21109E3	31109E3	-	
	22	7.7 x 12.7	82	6.2	0.09	6.5	3.2	1.1	-	21229E3	31229E3	-	
	100	10 x 18	230	14	0.08	1.3	0.7	0.30	-	21101E3	31101E3	-	
63	4.7	6.3 x 12.7	35	4.6	0.09	30	17	5	-	28478E3	38478E3	-	
	10	7.7 x 12.7	59	5.3	0.08	13	8	1.8	-	28109E3	38109E3	-	
	22	6.5 x 18	100	6.8	0.07	5.1	3.6	0.85	-	28229E3	38229E3	-	
	47	8 x 18	150	9.9	0.07	2.4	1.7	0.50	-	28479E3	38479E3	-	
	100	10 x 25	280	17	0.07	1.1	0.8	0.27	-	28101E3	38101E3	-	
	150	10 x 30	410	23	0.11	0.73	0.44	0.40	18151E3	28151E3	-	-	
	220	12.5 x 30	560	32	0.11	0.50	0.31	0.29	18221E3	28221E3	-	-	
	330	12.5 x 30	660	46	0.12	0.37	0.23	0.22	18331E3	28331E3	-	-	
	470	15 x 30	860	63	0.12	0.26	0.16	0.16	18471E3	28471E3	-	48471E3	
680	18 x 30	1130	90	0.12	0.19	0.12	0.14	18681E3	-	-	48681E3		
1000	18 x 38	1460	130	0.12	0.13	0.086	0.11	18102E3	-	-	48102E3		
1500	21 x 38	1680	190	0.13	0.10	0.072	0.11	18152E3	-	-	48152E3		
100	1.0	6.3 x 12.7	16	4.2	0.09	140	55	10	-	29108E3	39108E3	-	
	2.2	6.3 x 12.7	24	4.4	0.09	65	25	8	-	29228E3	39228E3	-	
	4.7	7.7 x 12.7	40	4.9	0.08	27	17	5	-	29478E3	39478E3	-	
	10	6.5 x 18	67	6.0	0.07	11	8	2.4	-	29109E3	39109E3	-	
	22	8 x 18	100	8.4	0.07	5.1	3.6	1.4	-	29229E3	39229E3	-	
	47	10 x 25	190	13	0.07	2.4	1.7	0.67	-	29479E3	39479E3	-	
	68	10 x 30	300	18	0.07	1.7	1.1	0.97	19689E3	29689E3	-	-	
	100	12.5 x 30	410	24	0.07	1.1	0.77	0.67	19101E3	29101E3	-	-	
	150	15 x 30	550	34	0.07	0.78	0.52	0.46	19151E3	29151E3	-	49151E3	
	220	15 x 30	650	48	0.07	0.54	0.37	0.33	19221E3	29221E3	-	49221E3	
	330	18 x 30	880	70	0.08	0.38	0.27	0.24	19331E3	-	-	49331E3	
470	18 x 38	1130	98	0.08	0.27	0.19	0.17	19471E3	-	-	49471E3		
680	21 x 38	1330	140	0.09	0.21	0.14	0.14	19681E3	-	-	49681E3		



ADDITIONAL ELECTRICAL DATA				
PARAMETER	CONDITIONS	VALUE		
		AXIAL	MOUNTING RING	
<b>Voltage</b>				
Surge voltage		$U_s \leq 1.15 \times U_R$		
Reverse voltage		$U_{rev} \leq 1 \text{ V}$		
<b>Current</b>				
Leakage current	After 1 minute at $U_R$ : case $\varnothing D \times L = 6.3 \times 12.7$ and $7.7 \times 12.7$ mm case $\varnothing D \times L = 6.5 \times 18$ to $21 \times 38$ mm	$I_{L1} \leq 0.02 C_R \times U_R + 3 \mu\text{A}$ $I_{L1} \leq 0.006 C_R \times U_R + 4 \mu\text{A}$		
	After 5 minutes at $U_R$	$I_{L5} \leq 0.002 C_R \times U_R + 4 \mu\text{A}$		
<b>Inductance</b>				
Equivalent series inductance (ESL)	Case $\varnothing D \times L$ mm:			
		6.3 x 12.7	typ. 20 nH	-
		7.7 x 12.7	typ. 30 nH	-
		6.5 x 18	typ. 15 nH	-
		8 x 18	typ. 35 nH	-
		10 x 18	typ. 69 nH	-
		10 x 25	typ. 38 nH	-
		10 x 30	typ. 38 nH	-
		12.5 x 30	typ. 46 nH	-
		15 x 30	typ. 48 nH	typ. 39 nH
		18 x 30	typ. 50 nH	typ. 39 nH
		18 x 38	typ. 54 nH	typ. 39 nH
		21 x 38	typ. 59 nH	typ. 39 nH

**CAPACITANCE (C)**

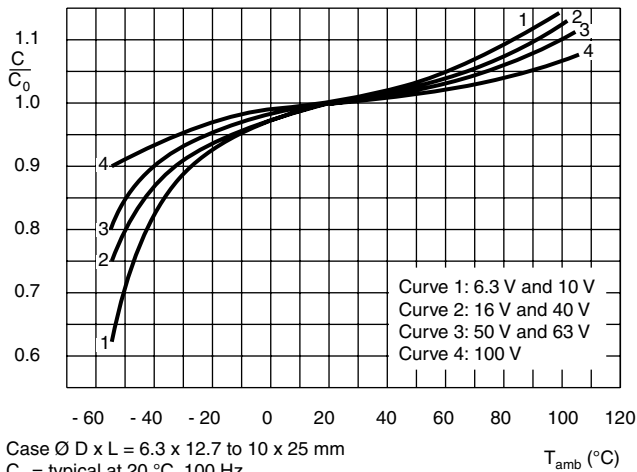

Fig.6 Typical multiplier of capacitance as a function of ambient temperature

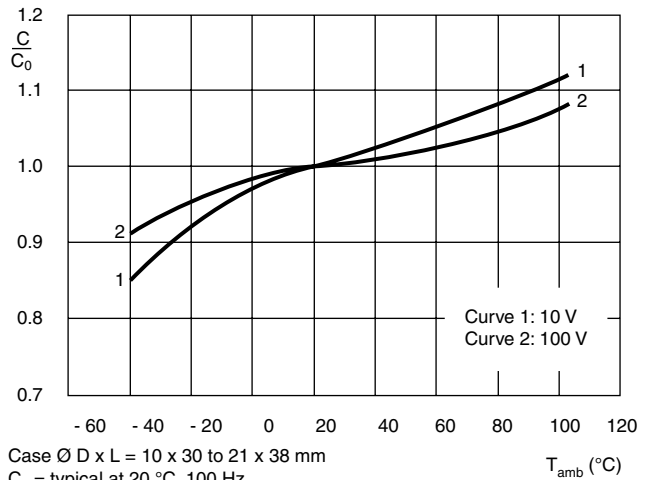

Fig.7 Typical multiplier of capacitance as a function of ambient temperature

**EQUIVALENT SERIES RESISTANCE (ESR)**

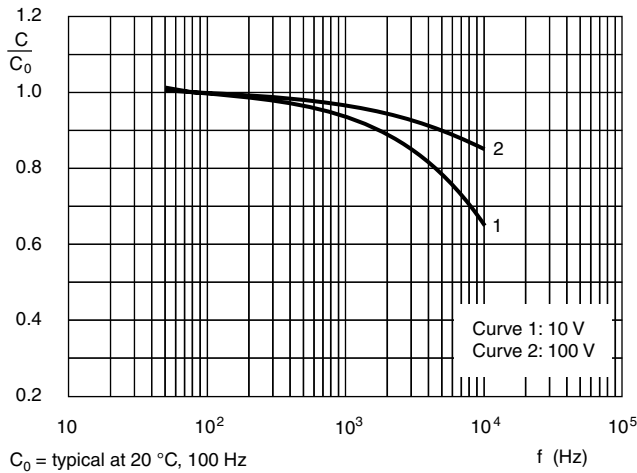

Fig.8 Typical multiplier of capacitance as a function of frequency

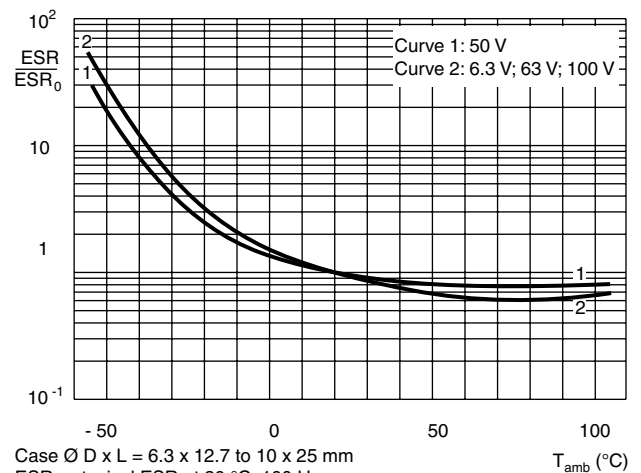

Fig.9 Typical multiplier of ESR as a function of ambient temperature

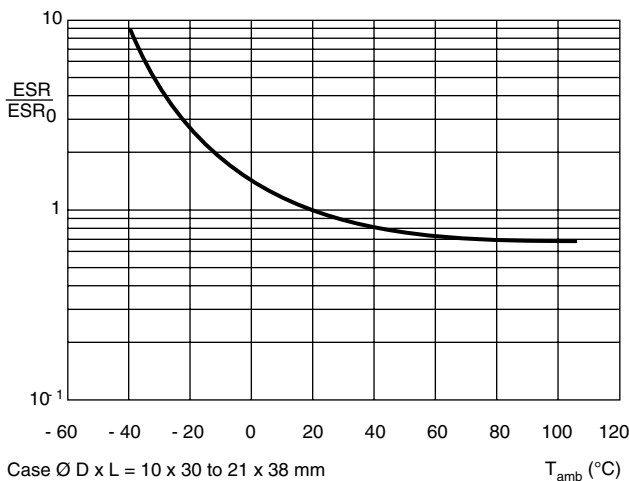

Fig.10 Typical multiplier of ESR as a function of ambient temperature

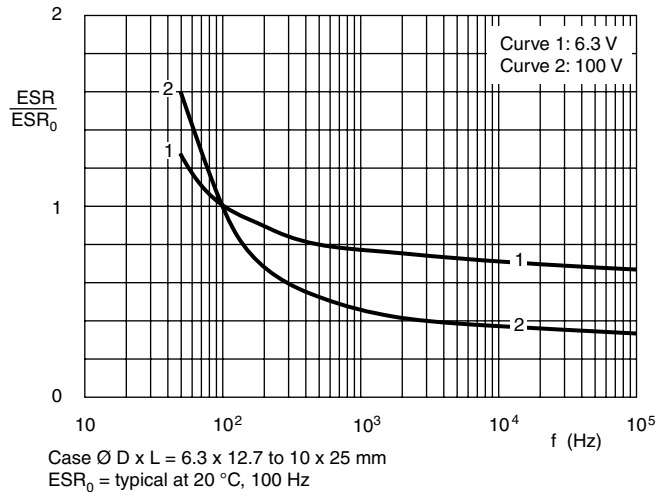

Fig.11 Typical multiplier ESR as a function of frequency

**EQUIVALENT SERIES RESISTANCE (ESR)**

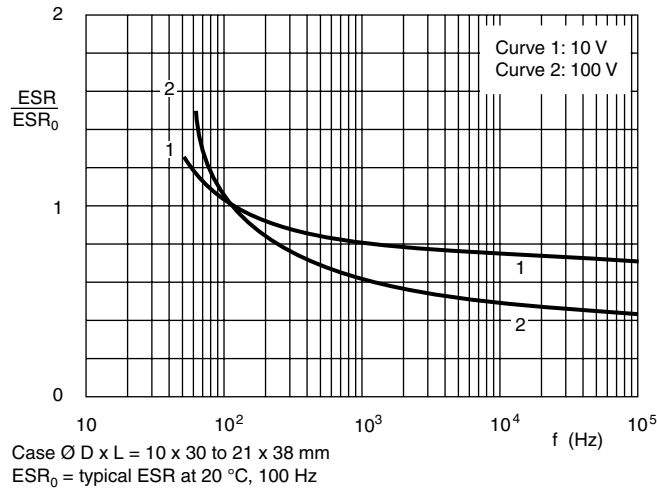

Fig.12 Typical multiplier ESR as a function of frequency

**IMPEDANCE (Z)**

Table 4

<b>IMPEDANCE VS. CAPACITANCE VALUES</b> (case $\varnothing D \times L = 6.3 \times 12.7$ to $10 \times 25$ mm)								
$T_{amb}$	<b>Z x C<sub>R</sub> (<math>\Omega \times \mu F</math>) AT 10 kHz</b>							
	6.3 V	10 V	16 V	25 V	40 V	50 V	63 V	100 V
+ 20 °C	≤ 300	≤ 200	≤ 160	≤ 120	≤ 90	≤ 70	≤ 80	≤ 80
- 25 °C	≤ 2000	≤ 1200	≤ 750	≤ 560	≤ 450	≤ 300	≤ 550	≤ 550
- 40 °C	≤ 5500	≤ 3200	≤ 2000	≤ 1500	≤ 1200	≤ 900	≤ 1500	≤ 1500

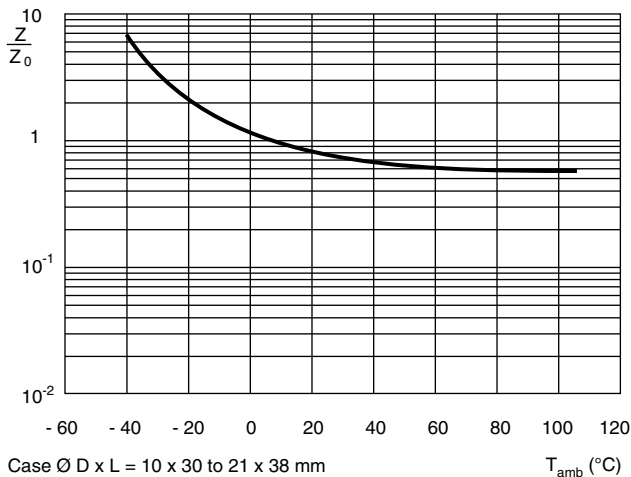

Fig.13 Typical multiplier of ESR as a function of ambient temperature at 10 kHz

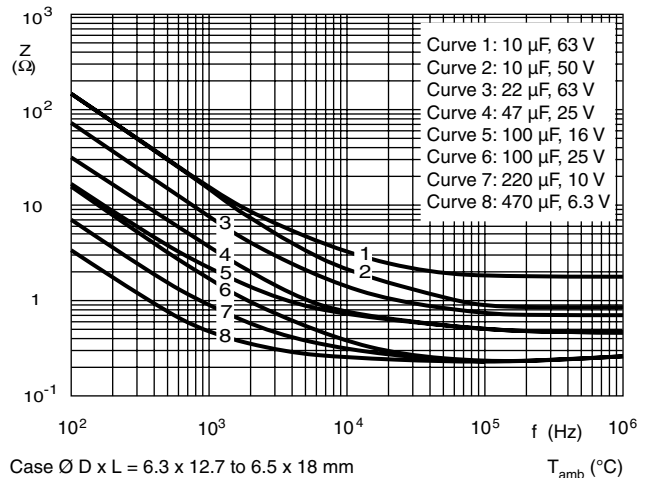

Fig.14 Typical impedance as a function of frequency



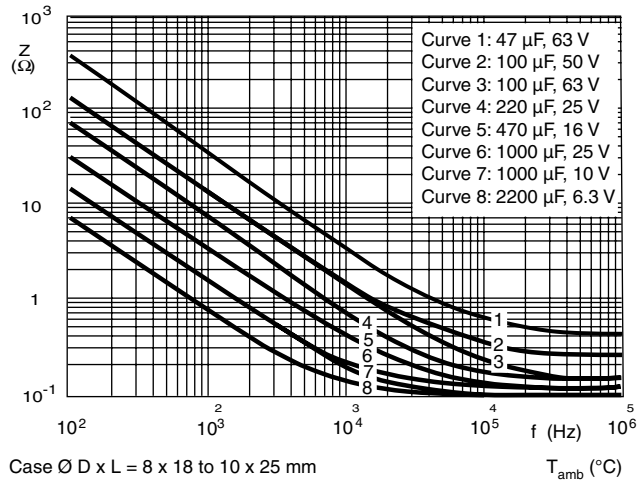

Fig.15 Typical impedance as a function of frequency

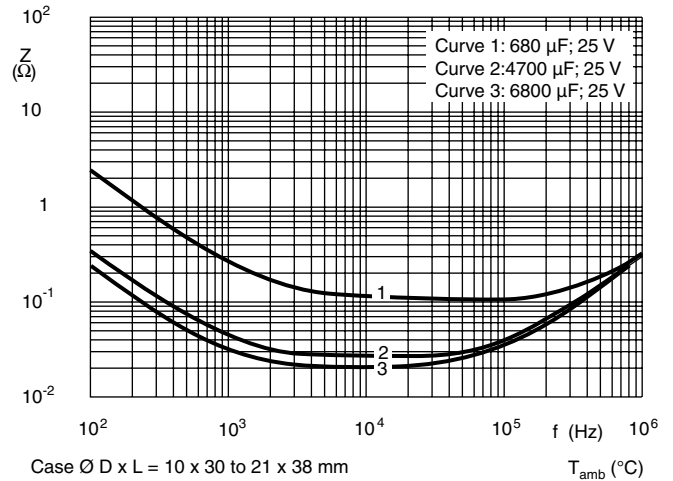

Fig.16 Typical impedance as a function of frequency

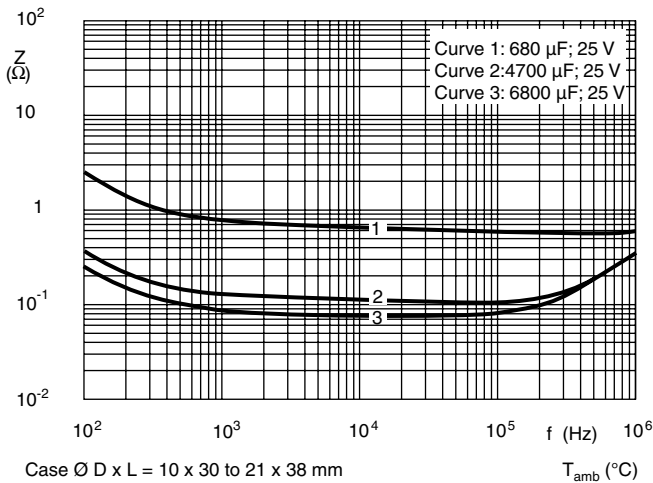

Fig.17 Typical impedance as a function of frequency

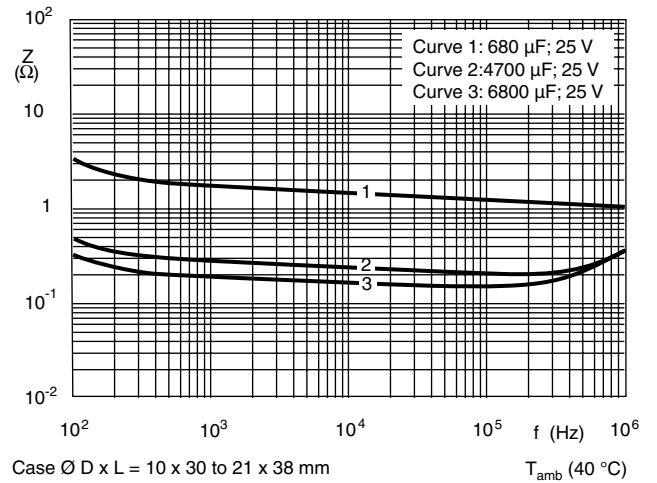
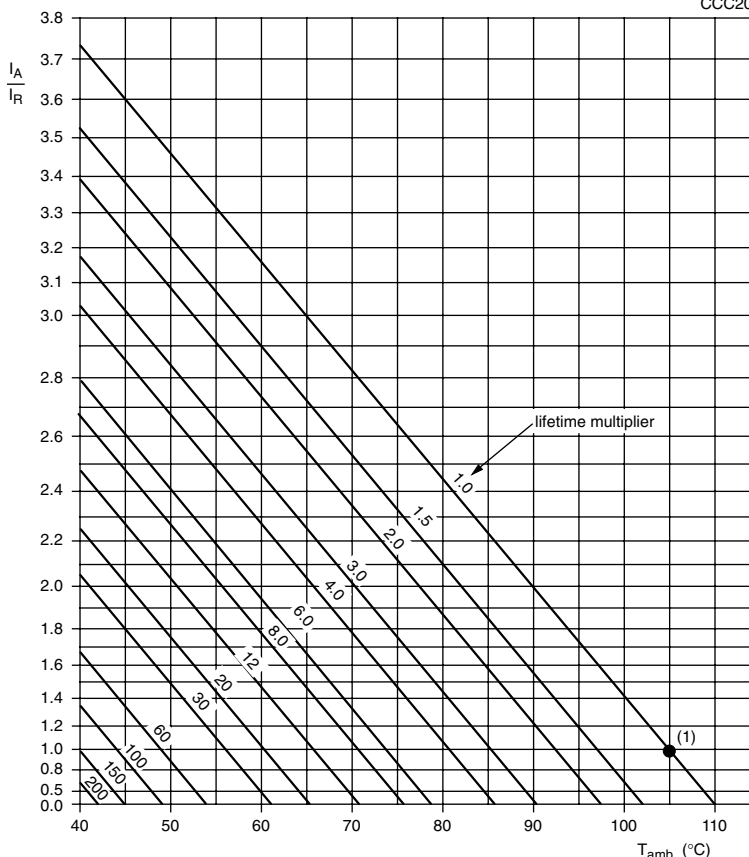

Fig.18 Typical impedance as a function of frequency



**RIPPLE CURRENT AND USEFUL LIFE**

CCC206



$I_A$  = actual ripple current at 100 Hz

$I_R$  = rated ripple current at 100 Hz, 105 °C

(1) Useful life at 105 °C and  $I_R$  applied:  
 case  $\varnothing D \times L = 6.3 \times 12.7$  to  $10 \times 25$  mm: 2000 hours  
 case  $\varnothing D \times L = 10 \times 30$  to  $21 \times 38$  mm: 10 000 hours

Fig.19 Multiplier of useful life as a function of ambient temperature and ripple current load

Table 5

<b>MULTIPLIER OF RIPPLE CURRENT (<math>I_R</math>) AS A FUNCTION OF FREQUENCY</b>			
<b>FREQUENCY (Hz)</b>	<b><math>I_R</math> MULTIPLIER</b>		
	<b><math>U_R = 6.3</math> to <math>10</math> V</b>	<b><math>U_R = 16</math> to <math>25</math> V</b>	<b><math>U_R = 40</math> to <math>100</math> V</b>
50	0.95	0.90	0.85
100	1.00	1.00	1.00
300	1.07	1.12	1.20
1000	1.12	1.20	1.30
3000	1.15	1.25	1.35
$\geq 10\ 000$	1.20	1.30	1.40



Table 6

<b>TEST PROCEDURES AND REQUIREMENTS</b>			
<b>TEST</b>		<b>PROCEDURE (quick reference)</b>	<b>REQUIREMENTS</b>
<b>NAME OF TEST</b>	<b>REFERENCE</b>		
Endurance	IEC 60384-4/ EN130300 subclause 4.13	$T_{amb} = 105\text{ }^{\circ}\text{C}$ ; $U_R$ applied; case $\varnothing D \times L$ : 6.3 x 12.7 to 10 x 25 mm: 1000 hours; 10 x 30 to 21 x 38 mm: 5000 hours	$U_R \leq 6.3\text{ V}$ ; $\Delta C/C$ : + 15/- 30 % $U_R > 6.3\text{ V}$ ; $\Delta C/C$ : $\pm 15\%$ $\tan \delta \leq 1.3 \times \text{spec. limit}$ $Z \leq 2 \times \text{spec. limit}$ $I_{L5} \leq \text{spec. limit}$
Useful life	CECC 30301 subclause 1.8.1	$T_{amb} = 105\text{ }^{\circ}\text{C}$ ; $U_R$ and $I_R$ applied; case $\varnothing D \times L$ : 6.3 x 12.7 to 10 x 25 mm: 2000 hours; 10 x 30 to 21 x 38 mm: 10 000 hours	$U_R \leq 6.3\text{ V}$ ; $\Delta C/C$ : + 45/- 50 % $U_R > 6.3\text{ V}$ ; $\Delta C/C$ : $\pm 45\%$ $\tan \delta \leq 3 \times \text{spec. limit}$ $Z \leq 3 \times \text{spec. limit}$ $I_{L5} \leq \text{spec. limit}$ no short or open circuit total failure percentage: $\leq 1\%$
Shelf life (storage at high temperature)	IEC 60384-4/ EN130300, subclause 4.17	$T_{amb} = 105\text{ }^{\circ}\text{C}$ ; no voltage applied; 500 hours  after test: $U_R$ to be applied for 30 minutes, 24 to 48 hours before measurement	$\Delta C/C$ , $\tan \delta$ , $Z$ : for requirements see 'Endurance test' above $I_{L5} \leq 2 \times \text{spec. limit}$



## Disclaimer

All product specifications and data are subject to change without notice.

Vishay Intertechnology, Inc., its affiliates, agents, and employees, and all persons acting on its or their behalf (collectively, "Vishay"), disclaim any and all liability for any errors, inaccuracies or incompleteness contained herein or in any other disclosure relating to any product.

Vishay disclaims any and all liability arising out of the use or application of any product described herein or of any information provided herein to the maximum extent permitted by law. The product specifications do not expand or otherwise modify Vishay's terms and conditions of purchase, including but not limited to the warranty expressed therein, which apply to these products.

No license, express or implied, by estoppel or otherwise, to any intellectual property rights is granted by this document or by any conduct of Vishay.

The products shown herein are not designed for use in medical, life-saving, or life-sustaining applications unless otherwise expressly indicated. Customers using or selling Vishay products not expressly indicated for use in such applications do so entirely at their own risk and agree to fully indemnify Vishay for any damages arising or resulting from such use or sale. Please contact authorized Vishay personnel to obtain written terms and conditions regarding products designed for such applications.

Product names and markings noted herein may be trademarks of their respective owners.