



MBR3035CT THRU MBR30100CT

30.0 AMPS. Schottky Barrier Rectifiers



Voltage Range
35 to 100 Volts
Current
30.0 Amperes

Features

- ✦ Plastic material used carries Underwriters Laboratory Classifications 94V-0
- ✦ Metal silicon junction, majority carrier conduction
- ✦ Low power loss, high efficiency
- ✦ High current capability, low forward voltage drop
- ✦ High surge capability
- ✦ For use in low voltage, high frequency inverters, free wheeling, and polarity protection applications
- ✦ Guardring for overvoltage protection
- ✦ High temperature soldering guaranteed:
260°C/10 seconds, 0.25" (6.35mm) from case

Mechanical Data

- ✦ Cases: JEDEC TO-220 molded plastic
- ✦ Terminals: Leads solderable per MIL-STD-750, Method 2026
- ✦ Polarity: As marked
- ✦ Mounting position: Any
- ✦ Mounting torque: 5 in. - lbs. max
- ✦ Weight: 0.08 ounce, 2.24 grams

TO-220

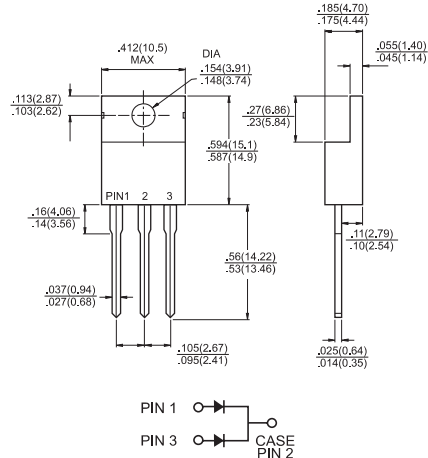

Dimensions in inches and (millimeters)

Maximum Ratings and Electrical Characteristics

Rating at 25°C ambient temperature unless otherwise specified.

Single phase, half wave, 60 Hz, resistive or inductive load.

For capacitive load, derate current by 20%

Type Number	Symbol	MBR 3035 CT	MBR 3045 CT	MBR 3050 CT	MBR 3060 CT	MBR 3090 CT	MBR 30100 CT	Units
Maximum Recurrent Peak Reverse Voltage	V_{RRM}	35	45	50	60	90	100	V
Maximum RMS Voltage	V_{RMS}	24	31	35	42	63	70	V
Maximum DC Blocking Voltage	V_{DC}	35	45	50	60	90	100	V
Maximum Average Forward Rectified Current at $T_c=130^\circ\text{C}$	$I_{(AV)}$	30						A
Peak Repetitive Forward Current (Rated V_R , Square Wave, 20KHz) at $T_c=130^\circ\text{C}$	I_{FRM}	30.0						A
Peak Forward Surge Current, 8.3 ms Single Half Sine-wave Superimposed on Rated Load (JEDEC method)	I_{FSM}	250						A
Peak Repetitive Reverse Surge Current (Note 1)	I_{RRM}	1.0			0.5			A
Maximum Instantaneous Forward Voltage at (Note 2) $I_F=15\text{A}, T_c=25^\circ\text{C}$ $I_F=15\text{A}, T_c=125^\circ\text{C}$ $I_F=30\text{A}, T_c=25^\circ\text{C}$ $I_F=30\text{A}, T_c=125^\circ\text{C}$	V_F	0.7 0.6 0.82 0.73		0.75 0.65		0.84 0.70 0.94 0.82		V
Maximum Instantaneous Reverse Current @ $T_c=25^\circ\text{C}$ at Rated DC Blocking Voltage Per Leg @ $T_c=125^\circ\text{C}$ (Note 2)	I_R	0.2 40		0.2 50		0.2 60		mA mA
Voltage Rate of Change, (Rated V_R)	dV/dt	1,000						V/uS
Maximum Thermal Resistance Per Leg (Note 3)	$R_{\theta JC}$	1.0				1.5		$^\circ\text{C}/\text{W}$
Typical Junction Capacitance	C_j	600		460		320		pF
Operating Junction Temperature Range	T_J	-65 to +150						$^\circ\text{C}$
Storage Temperature Range	T_{STG}	-65 to +175						$^\circ\text{C}$

Notes: 1. 2.0us Pulse Width, $f=1.0$ KHz

2. Pulse Test: 300us Pulse Width, 1% Duty Cycle

3. Thermal Resistance from Junction to Case Per Leg, with Heatsink size (4"x6"x0.25") Al-Plate.

RATINGS AND CHARACTERISTIC CURVES (MBR3035CT THRU MBR30100CT)

FIG.1- FORWARD CURRENT DERATING CURVE

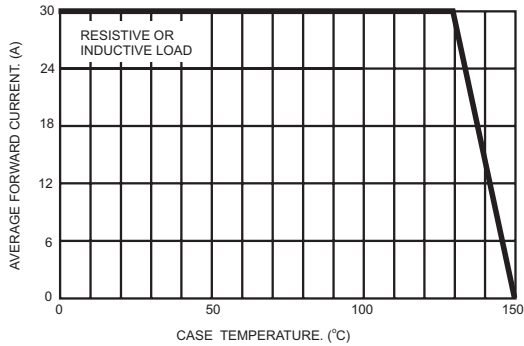

FIG.2- MAXIMUM NON-REPETITIVE FORWARD SURGE CURRENT PER LEG

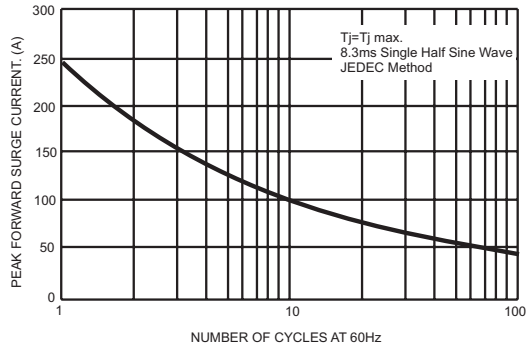

FIG.3- TYPICAL INSTANTANEOUS FORWARD CHARACTERISTICS PER LEG

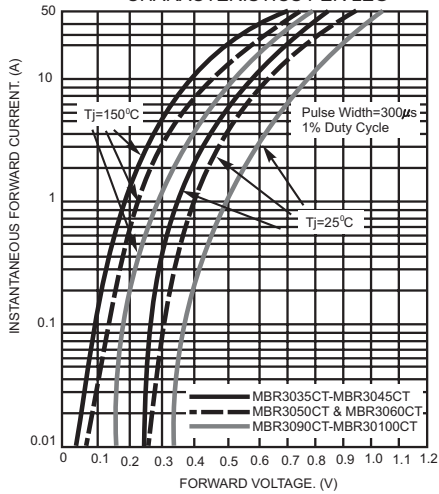

FIG.4- TYPICAL REVERSE CHARACTERISTICS PER LEG

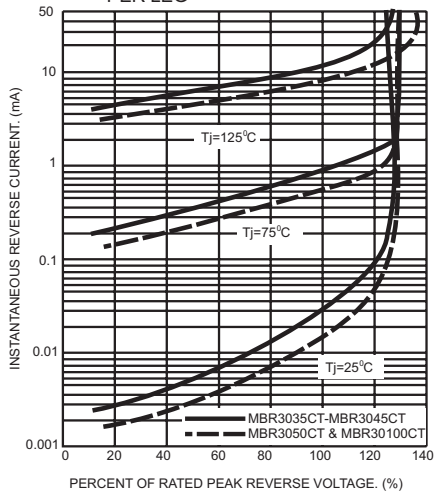

FIG.5- TYPICAL JUNCTION CAPACITANCE PER LEG

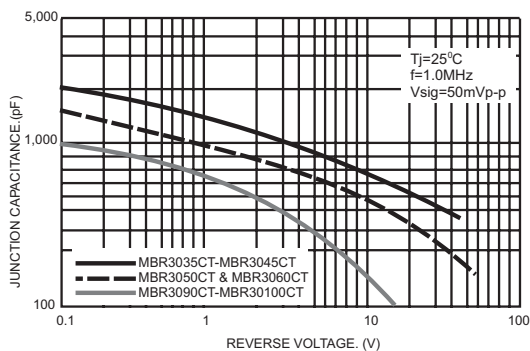

FIG.6- TYPICAL TRANSIENT THERMAL IMPEDANCE PER LEG

