

Features

- Peak Efficiency: 90%
- Individual Current Regulation
- 3-bit Digital Output Control
- Two modes of operation: 1x and 1.5x
- Current Matching with a Max Tolerance of 3%
- Output Current up to 30mA per LED
- Total LED Current up to 4*30mA=120mA
- Fixed Frequency of 1MHz
- Open LED Protection
- Space Saving Package QFN 3mmx3mm and QFN 4mmx4mm
- Pb-Free Package

Applications

- Cellular Phones
- LED Backlighting
- LCD Modules
- Handheld Devices
- Digital Cameras
- PDAs
- PMPs
- MP3 Players

Description

The PAM2701 is a 4-channel charge pump white LED driver, capable of driving up to 4 LEDs in parallel. The device operates in either 1x mode or 1.5x fractional mode, and it can switch from 1x mode to 1.5x mode automatically when the input voltage decreased. Its internal 4 current sink regulators ensure both the LED current matching and the brightness uniformity. The LED current can be programmed by an external resistor, R_{SET} , connected between the RSET pin and ground. LED current of up to 30mA are supported by the input supply voltage over a range of 2.7V to 5.5V, making the device optimized for Li-Ion battery applications.

The PAM2701 has a fixed switching frequency of 1MHz, allowing the use of very small value ceramic capacitors. The enable input pin allows the device to be set in shutdown mode, and the current consumption is reduced to less than 1µA.

LED dimming can be done by several methods including using a DC voltage to set the RSET pin current, adding a switched resistor in parallel with R_{SET} , or applying a PWM signal to CTRx pin or EN pin.

Typical Application

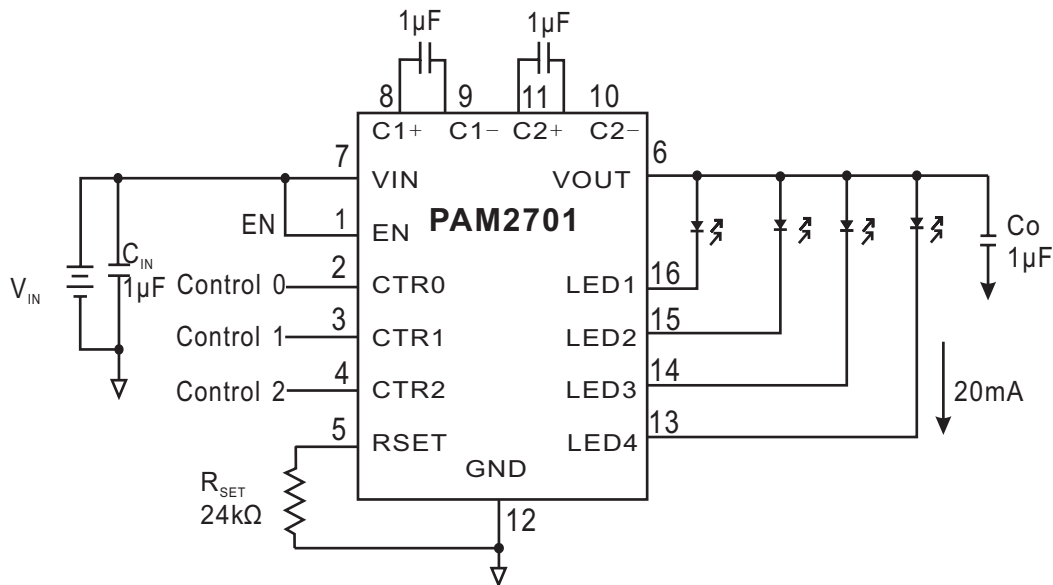

Block Diagram

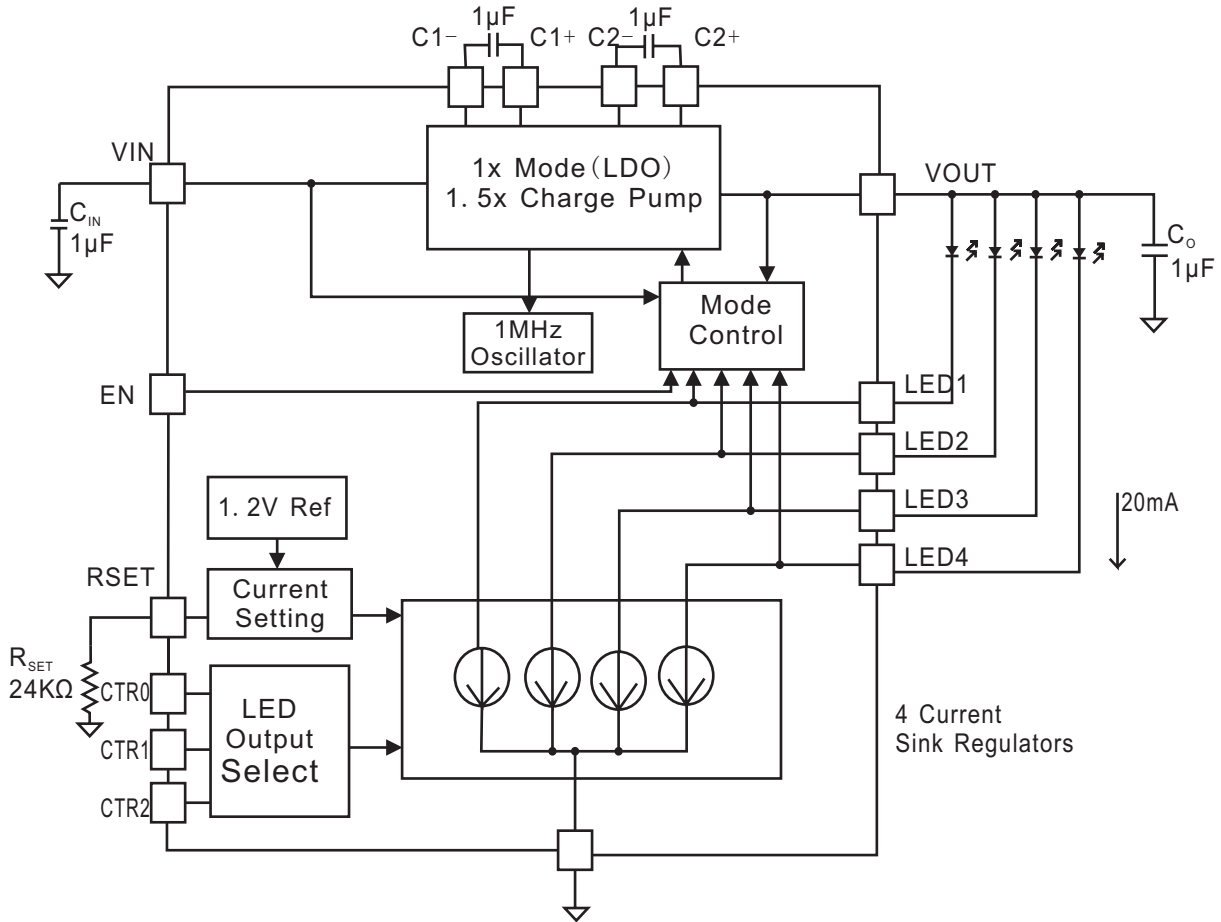
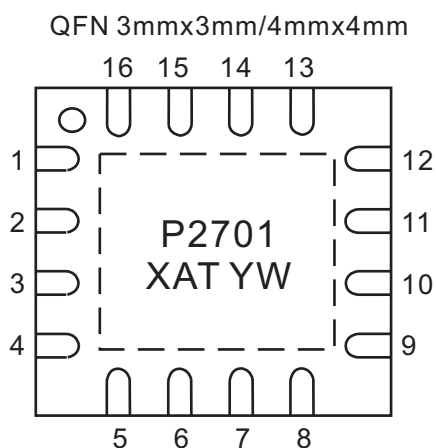

Table 1: LED Enable Logic

Control Lines			LED Outputs			
CTR2	CTR1	CTR0	LED4	LED3	LED2	LED1
0	0	0	-	-	-	ON
0	0	1	-	-	ON	-
0	1	0	-	ON	-	-
0	1	1	ON	-	-	-
1	0	0	-	-	ON	ON
1	0	1	-	ON	ON	ON
1	1	0	ON	ON	ON	ON
1	1	1	-	-	-	-

Note: 1=logic high (or V_{IN})
 0=logic low (or GND)
 -=LED output off

Pin Configuration & Marking Information



X: Internal Code
 A: Assembly Code
 T: Testing Code
 Y: Year
 W: Week

Pin Number	Name	Function
1	EN	Enable Input, Active High
2	CTR0	Digital Control Input 0
3	CTR1	Digital Control Input 1
4	CTR2	Digital Control Input 2
5	RSET	Set Resistance
6	VOUT	Charge pump output connected to the LED anodes
7	VIN	Supply Voltage
8	C1+	Bucket Capacitor 1 Terminal
9	C1-	Bucket Capacitor 1 Terminal
10	C2-	Bucket Capacitor 2 Terminal
11	C2+	Bucket Capacitor 2 Terminal
12	GND	Ground Reference
13	LED4	LED4 Cathode Terminal
14	LED3	LED3 Cathode Terminal
15	LED2	LED2 Cathode Terminal
16	LED1	LED1 Cathode Terminal



Absolute Maximum Ratings

These are stress ratings only and functional operation is not implied. Exposure to absolute maximum ratings for prolonged time periods may affect device reliability. All voltages are with respect to ground.

VIN, VOUT, LEDx Pin Voltage.....-0.3V to 6.6V	Storage Temperature Range.....-65°C to 150°C
EN, CTRx Pin Voltage.....-0.3V to V _{IN}	Lead Temperature.....300°C
RSET Pin Voltage.....-0.3V to V _{IN}	ESD Ratings
Ambient Temperature Range.....-40°C to 85°C	Human Body Model (HBM).....2000V

Recommended Operating Conditions

V _{IN}2.7V to 5.5V	Input/Output/Bucket Capacitors....1±20%µF(TYP.)
Max. Supply Voltage (for Max. duration of 30 minutes).....6.4V	Ambient Temperature.....-40°C to 85°C
	I _{LED} per LED.....0mA to 30mA

Thermal Information

Parameter	Symbol	Package	Maximum	Unit
Thermal Resistance (Junction to Ambient)	θ_{JA}	QFN 3*3mm	34	°C/W
		QFN 4*4mm	25	
Power Dissipation, P _D @T _A =25°C	P _D	QFN 3*3mm	2.9	W
		QFN 4*4mm	4.0	



PAM2701

4-Channel Regulated Charge Pump White LED Driver

Electrical Characteristic

$T_A=25^{\circ}\text{C}$, $V_{IN}=3.5\text{V}$, $C_{IN}=C_O=1\mu\text{F}$, unless otherwise noted.

Parameter	Symbol	Conditions	Min	Typ	Max	Unit
Input Voltage Range	V_{IN}		2.7		5.5	V
Shutdown Current	I_{SD}	$V_{EN}=0\text{V}$ Shutdown Mode		0.05	1	μA
Quiescent Current	I_Q	1x Mode, No Load		0.6	1.2	mA
		1.5x Mode, No Load		2.5	5	mA
RSET Regulated Voltage	V_{RSET}		1.19	1.23	1.25	V
Programmed LED Current	I_{LED}	$R_{SET}=90\text{k}\Omega$		5.0		mA
		$R_{SET}=29.3\text{k}\Omega$		15.0		mA
		$R_{SET}=14.7\text{k}\Omega$		30.0		mA
LED Current Accuracy	$I_{LED-ACC}$			± 5		%
LED Channel Matching	$I_{LED-DEV}$	$(I_{LED}-I_{LEDAVG})/I_{LEDAVG}$		± 3		%
Output Resistance (Open Loop)	R_O	1x Mode, $I_O=100\text{mA}$		1.7		Ω
		1.5x Mode, $I_O=100\text{mA}$		4.3		Ω
Charge Pump Frequency	f_{OSC}			1.0		MHz
V_{IN} at Mode Transition from 1x to 1.5x	$V_{IN-Tran}$	$I_{LED}=15\text{mA}$		3.45		V
		$I_{LED}=20\text{mA}$		3.60		V
1x to 1.5x Mode Transition Dropout Delay	T_{DROP}			10		μs
Input Leakage Current	I_{EN-CTR}	On Inputs EN,CTR0,1&2			1	μA
High Detect Threshold	$V_{EN-CTRH}$	On Inputs EN,CTR0,1&2	1.5			V
Low Detect Threshold	$V_{EN-CTRL}$	On Inputs EN,CTR0,1&2			0.4	V

Typical Characteristics

$V_{IN} = 3.6V$, $EN = V_{IN}$, $R_{SET} = 24k\Omega$, $C_{IN} = C_O = 1\mu F$, $T_A = 25^\circ C$, unless otherwise noted.

1. Efficiency vs Input Voltage (4 LEDs)

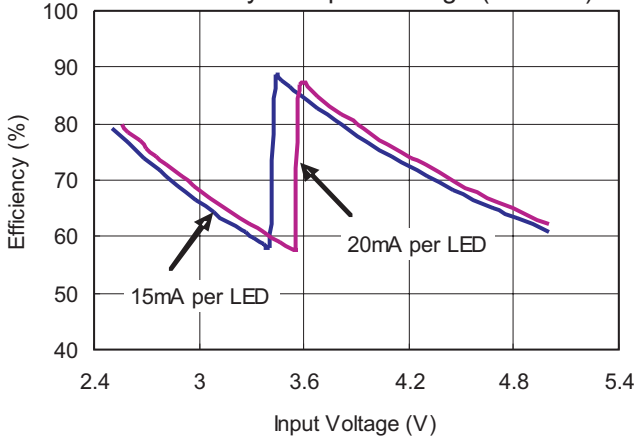

2. Efficiency vs Output Current (4 LEDs)

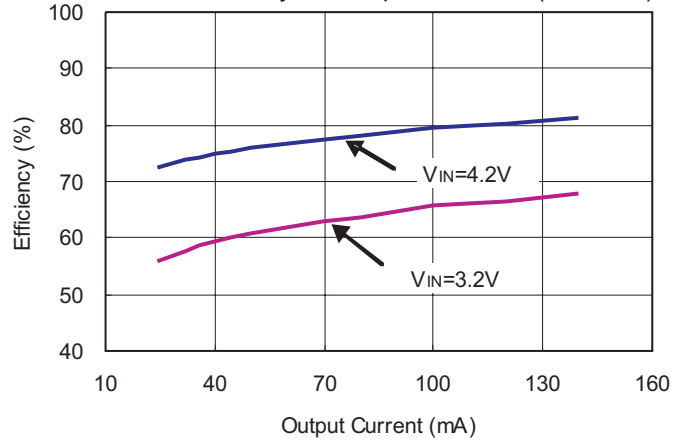

3. LED Current vs Input Voltage (4 LEDs)

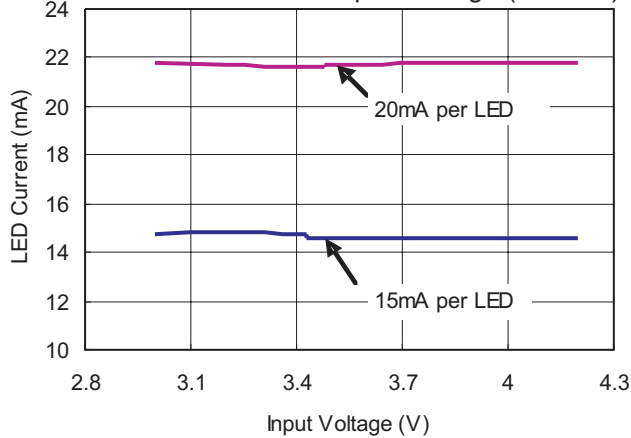

4. Supply Current vs Input Voltage (4 LEDs)

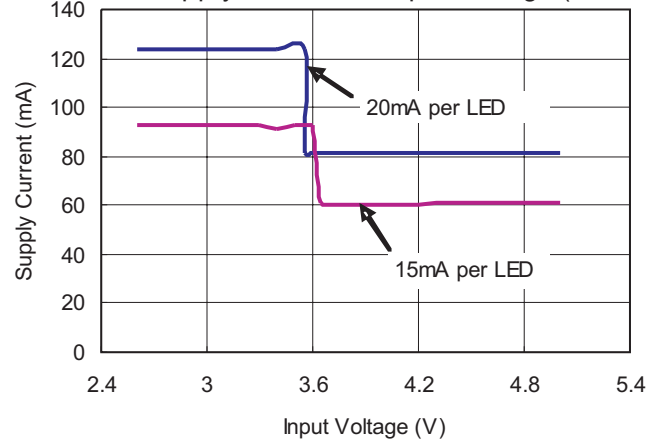

5. Ground Current vs Input Voltage

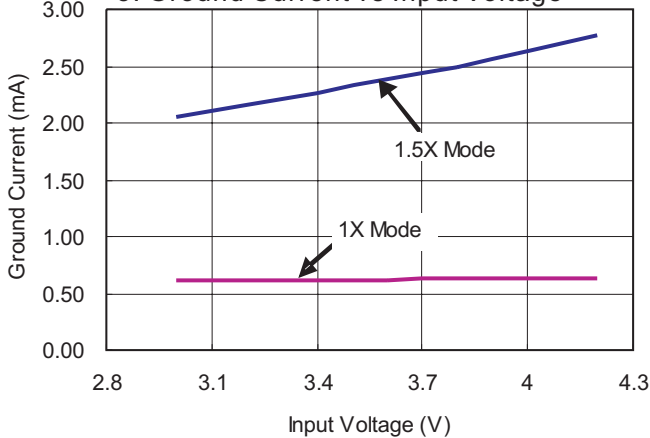

6. Oscillator Frequency vs Input Voltage

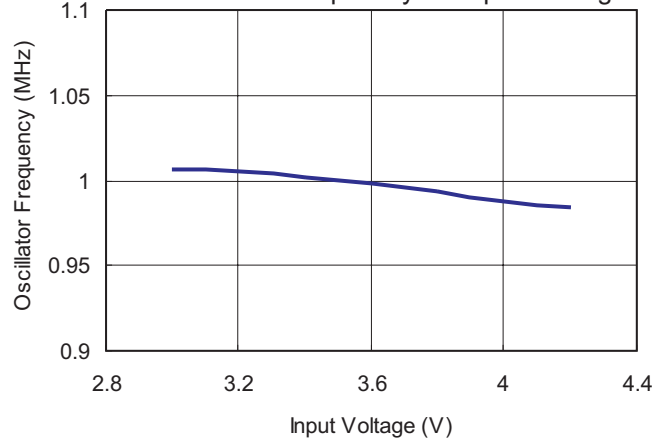

Typical Characteristics

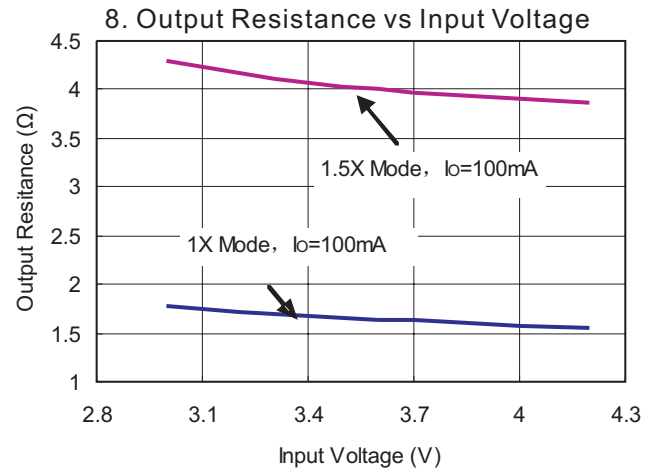
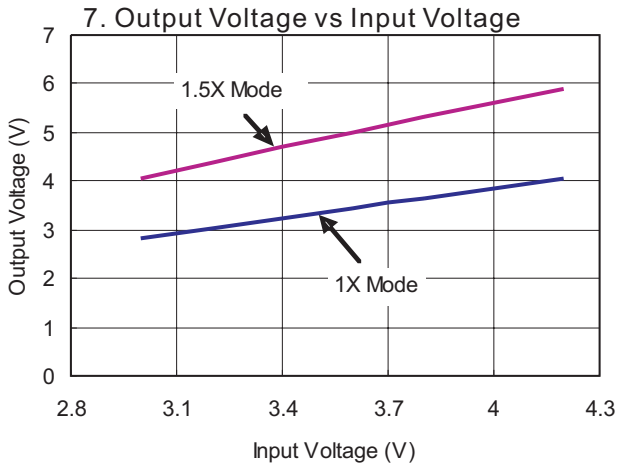

9. LED Current Setting Using the External Resistor R_{SET}

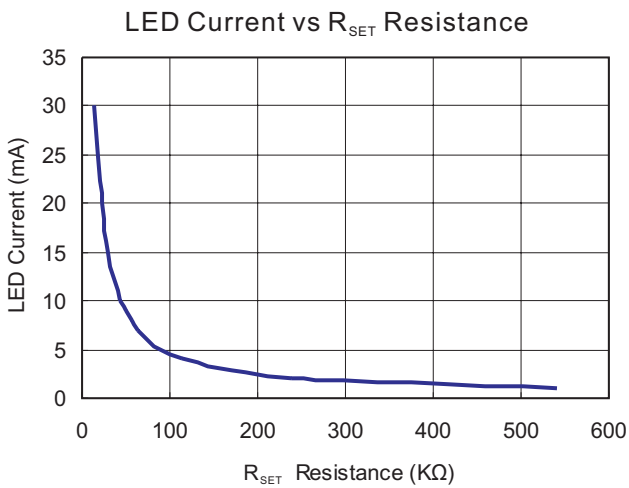

10. LED Current Setting Using a DC Voltage to RSET Pin

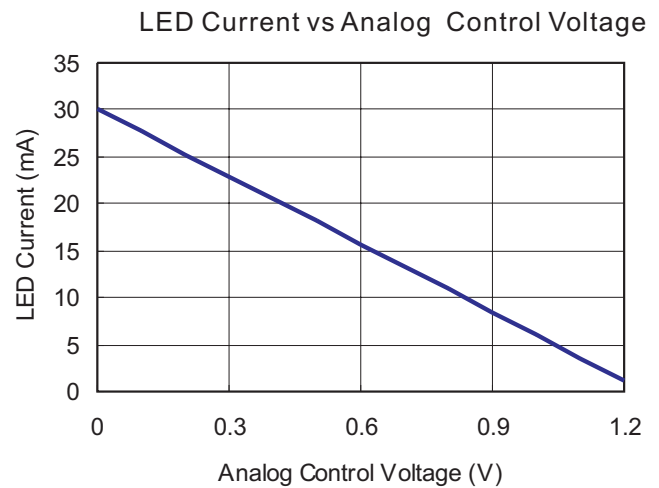

11. LED Current Setting Using a PWM Signal to EN Pin

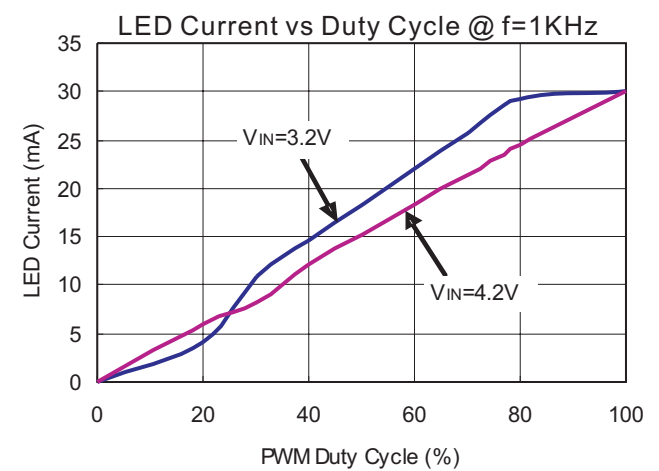
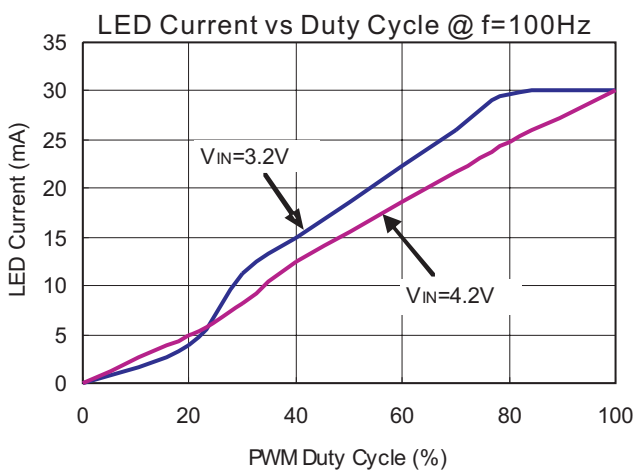

Typical Characteristics

12. LED Current Setting Using a PWM Signal to CTR0 Pin
LED Current vs Duty Cycle @ f=100HZ

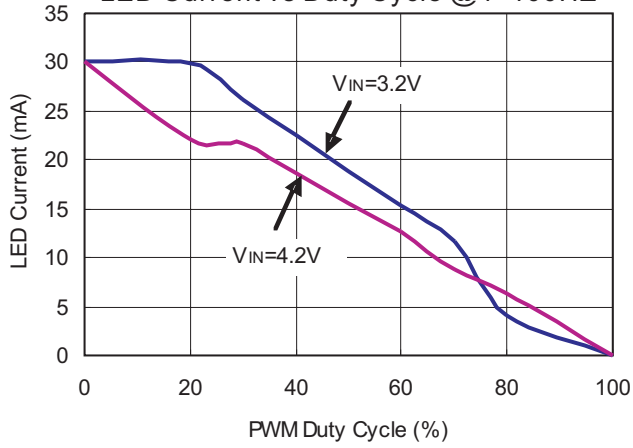

LED Current vs Duty Cycle @ f=1KHZ

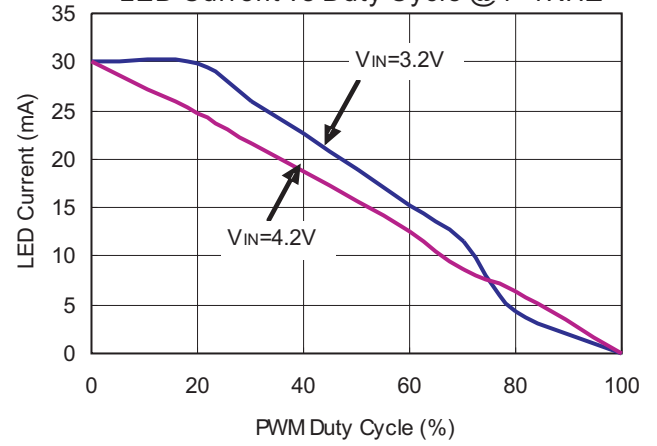

13. Output Ripple

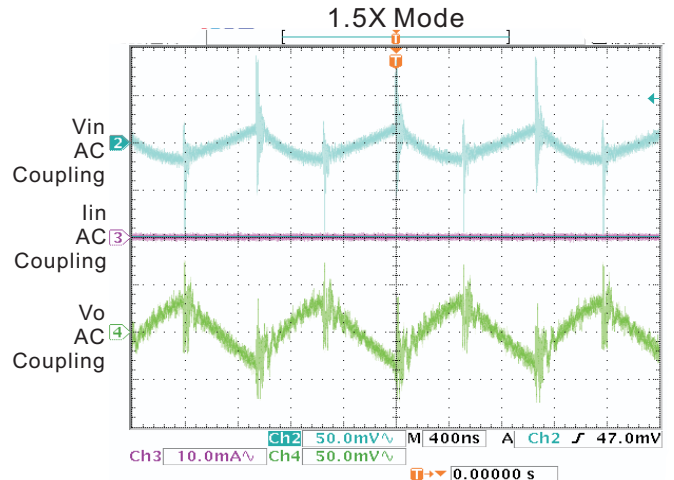
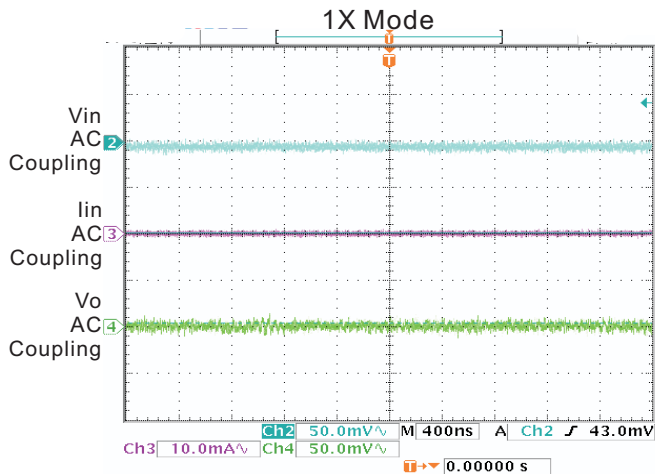

Application Information

Detailed Description

As shown in the block diagram on page 2, the main components within the PAM2701 include a fractional charge pump, mode selection circuit, output selection logic, LED current setting detection circuit, and 4 current sense circuits.

The fractional charge pump multiplies the input voltage a multiple of 1X and 1.5X times the input voltage. The charge pump switches at a fixed 1MHz when the mode is 1.5X. The charge pump does not switch during 1X mode, saving power and improving efficiency.

The mode selection circuit automatically selects the mode as 1X or 1.5X based on circuit conditions such as LED voltage, input voltage and load current. 1X is the more efficient mode than 1.5X mode.

Table 1 on page 2 shows the output selection logic control over the LED outputs for on and off functions with 8 different output states.

The current set and detection circuit uses an external resistor and a 1.20V reference to program the LED current.

4 current regulating circuits sink matched currents from the LEDs. LEDs with matched forward voltage will produce the best possible matched currents. For best matching performance it is recommended that the V_f between LEDs be under 250mV.

The unused LED channels can be turned off by CTR0, CTR1 and CTR2, and connecting the respective LED pins to VOUT pin, in which case, the corresponding LED driver sink current is only about 20 μ A.

Methods for Setting LED Current

There are 4 methods for setting and adjusting the LED current outlined here. The methods are:

- 1) R_{SET} only
- 2) Analog Reference V_{SET}
- 3) PWM Input at CTR0
- 4) PWM Input at EN

Method 1: LED Current Setting with an External Resistor R_{SET}

The most basic means of setting the LED current is connecting a resistor from R_{SET} to GND, as shown in the application circuit on Page 1.

The resistor R_{SET} establishes the reference current needed for a constant LED current. Values of R_{SET} for a fixed LED current are given in Table 2, "Typical R_{SET} Resistance vs. LED Current".

Table 2: R_{SET} Resistance Selection

I_{LED} (mA)	R_{SET} (k Ω)	Standard Value (k Ω)	Value % Difference
30	14.7	14.7	0.0%
20	21.8	22.0	0.9%
15	29.3	29.4	0.3%
10	44.1	44.2	0.2%
9	49.4	49.9	1.0%
8	55.7	56.0	0.5%
7	64.2	63.4	0.3%
6	75.0	75.0	0.0%
5	90.0	88.7	-0.3%
4	114.2	115.0	0.7%
3	156.5	158.0	0.9%
2	238.0	237.0	-0.4%
1	540.0	536.0	-0.7%

Method 2: LED Current Setting with a DC Voltage to RSET Pin

Method 2 is for setting the LED current to control brightness. An example circuit is shown in Figure 1, employing a 14.7k resistor and an analog input DC voltage, V_{SET} , which varies from 1.2V to 0V to control LED current from 1mA to 30mA. Table 3 shows the resulting output. If necessary, the analog V_{SET} voltage can be sourced from a voltage higher than 1.20V, but the source must be divided down so that the V_{SET} mode will not exceed 1.20V. For lower current and higher resolution applications, a larger resistor may be used instead. PWM applications are also possible with this circuit by application of RC filtering (Consult with PAM for detail application support).

Application Information

Table 3: Analog Voltage for LED Current Control

V _{SET} (V)	I _{LED} (mA)	V _{SET} (V)	I _{LED} (mA)
0.0	30.0	0.7	13.3
0.1	27.7	0.8	10.9
0.2	25.3	0.9	8.4
0.3	22.9	1.0	6.0
0.4	20.5	1.1	3.6
0.5	18.1	1.2	1.1
0.6	15.7		

Figure 1: Analog Voltage for LED Current Control

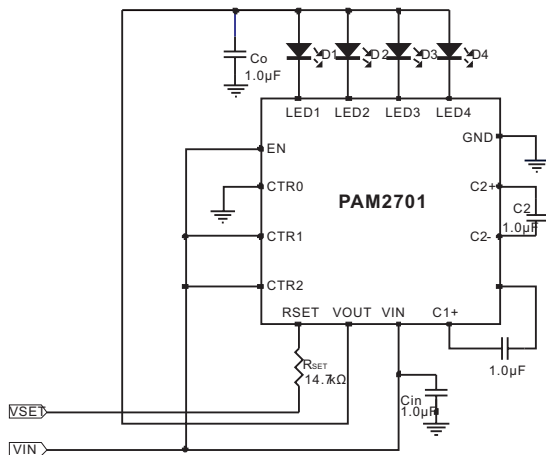

Method 3: LED Current Setting with a PWM Signal to CTRx Pin

In circuit in Figure 2 four LEDs are turned on and off by a PWM signal on the CTR0. A resistor R_{SET} is used to set the on state current and the average LED current is then proportional to the percentage of on-time when the CTR0 pin is logic low. Average LED current is approximately equal to:

$$I_{AVG} = (t_{ON} * I_{LED_ON}) / (t_{ON} + t_{OFF})$$

It is recommended that PWM frequency is between 100Hz and 1kHz. Due to start up delay and ramp up time, frequency >1kHz will result in error in the average value of I_{LED}. Frequency <100Hz can cause the LEDs to blink visibly.

Figure 2: PWM Signal at CTR0 pin for LED Current Control

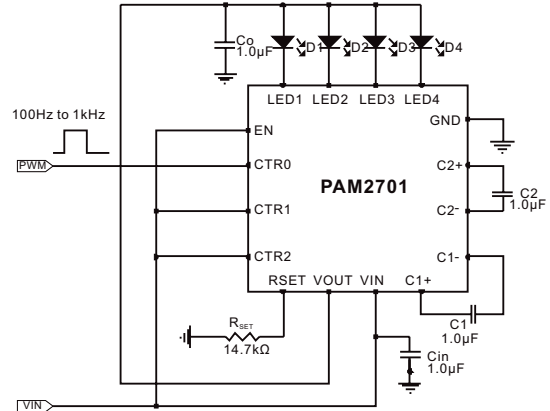

Method 4: LED Current Setting with a PWM Signal to EN Pin

The four LEDs are turned on and off by applying a PWM signal to the EN pin in circuit in Figure 3. The circuit is the same as one in method 3, using a resistor R_{SET} to set the on state current and the average LED current proportional to the percentage of on-time when the EN pin is logic low. Average LED current is approximately equal to:

$$I_{AVG} = (t_{ON} * I_{LED_ON}) / (t_{ON} + t_{OFF})$$

Similarly, it is recommended that PWM frequency is between 100Hz and 1kHz. Due to start up delay and ramp up time, frequency >1kHz will result in error in the average value of I_{LED}. Frequency <100Hz can cause the LEDs to blink visibly.

Figure 3: PWM Signal at EN pin for LED Current Control

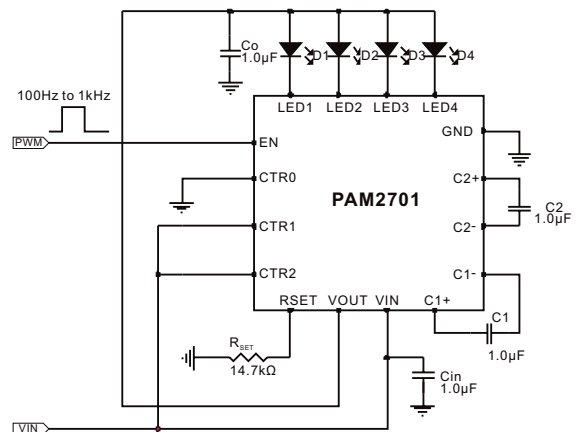

Application Information

PCB Layout

When the driver is in the 1.5X charge pump mode, the 1MHz switching frequency operation requires to minimize the trace length and impedance to ground on all 4 capacitors. A ground plane should cover the area on the bottom side of the PCB opposite to the IC and the bypass capacitors. Capacitors C_{IN} and C_O should be short connected to ground with multiple vias as shown on Figure4.

Square copper area matches the QFN 16 exposed pad (GND) which is connected by a trace to the pin 12 pad (GND). A large via (metalized hole) centered in the square pad provides a low impedance connection to the ground plane on the opposite side of the PCB and allows the heat dissipation of the LED driver to achieve excellent thermal performance.

Figure 4: PCB layout

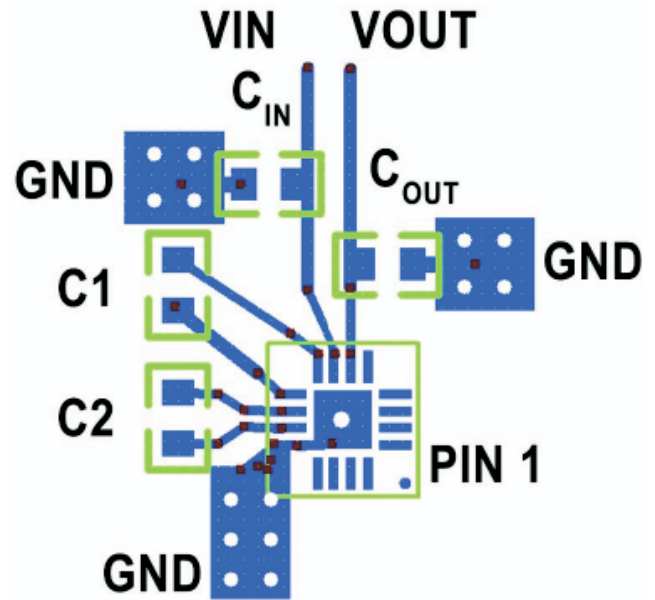



Ordering Information

PAM2701 X X X

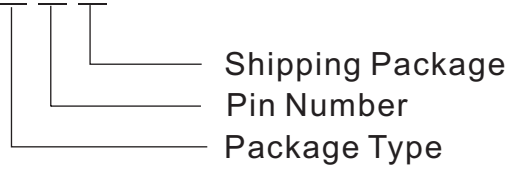

Package Type	Pin Number	Shipping Package
J: QFN 3mmx3mm K: QFN 4mmx4mm	E: 16	R: Tape & Reel

Part Number	Package Type	MOQ
PAM2701JER	Thin QFN-16 3mm×3mm	3,000 Units/Tape & Reel
PAM2701KER	Thin QFN-16 4mm×4mm	3,000 Units/Tape & Reel

Outline Dimension

3x3 mm TQFN 16

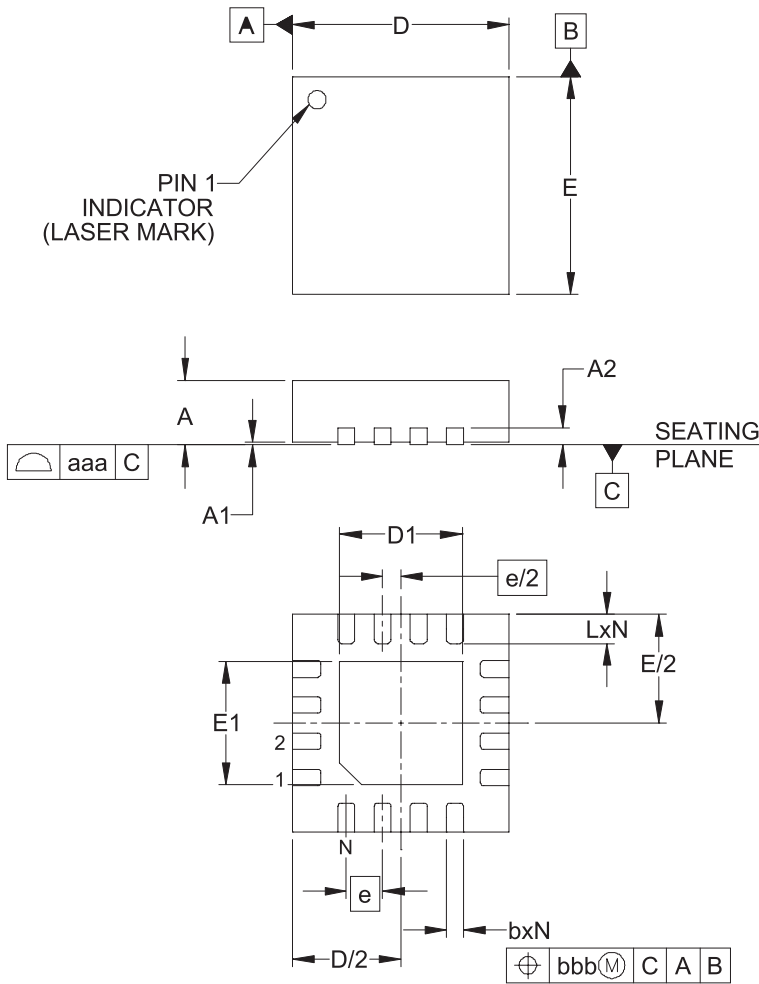

DIMENSIONS (Millimeters)			
	MIN	TYP	MAX
A	0.70	0.75	0.80
A1	0.00	0.02	0.05
A2	0.20		
b	0.18	0.25	0.30
D	2.90	3.00	3.10
D1	1.55	1.70	1.80
E	2.90	3.00	3.10
E1	1.55	1.70	1.80
e	0.50BSC		
L	0.30	0.40	0.50
N	16		
aaa	0.08		
bbb	0.10		

NOTES:

1. CONTROLLING DIMENSIONS ARE IN MILLIMETERS (ANGLES IN DEGREES).
2. COPLANARITY APPLIES TO THE EXPOSED PAD AS WELL AS THE TERMINALS.
3. DAP IS 1.90 x 1.90mm.

Outline Dimension

4x4mm QFN 16

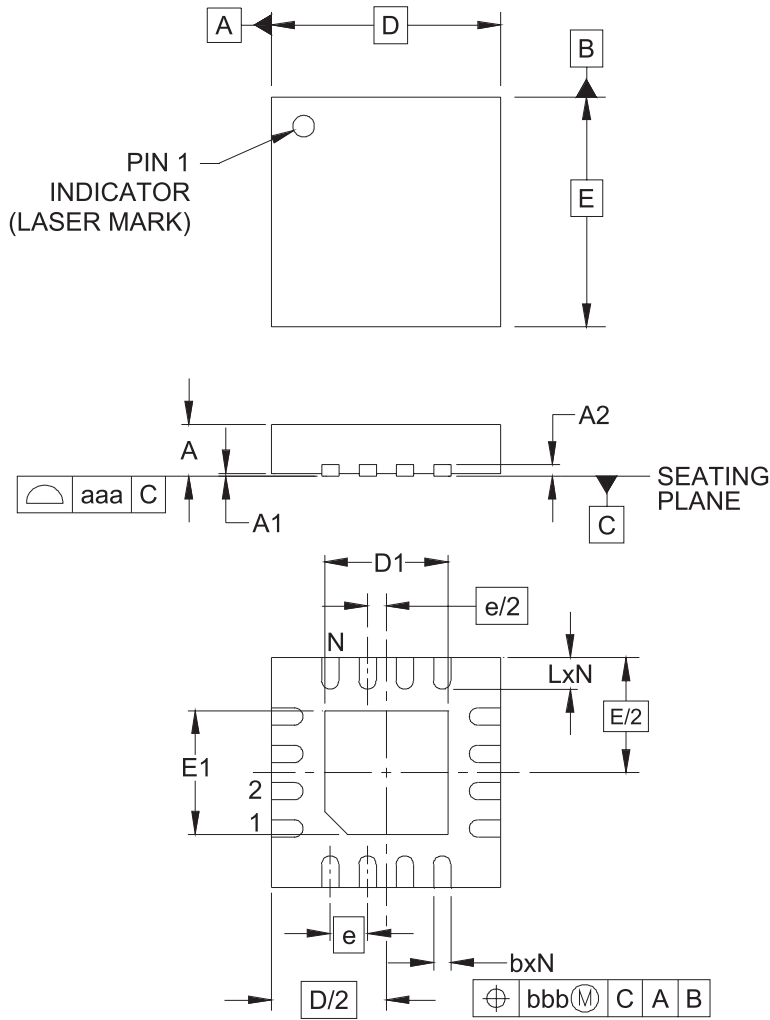

DIMENSIONS (Millimeters)			
	MIN	TYP	MAX
A	0.80	0.90	1.00
A1	0.00	0.02	0.05
A2	0.20		
b	0.25	0.30	0.35
D	3.90	4.00	4.10
D1	2.00	2.15	2.25
E	3.90	4.00	4.10
E1	2.00	2.15	2.25
e	0.65BSC		
L	0.45	0.55	0.65
N	16		
aaa	0.08		
bbb	0.10		

NOTES:

1. CONTROLLING DIMENSIONS ARE IN MILLIMETERS (ANGLES IN DEGREES).
2. COPLANARITY APPLIES TO THE EXPOSED PAD AS WELL AS THE TERMINALS.