

**TOSHIBA CMOS INTEGRATED CIRCUITS SILICON MONOLITHIC**

# TCA62735AFLG

## Charge Pump type DC/DC Converter for White LED Driver

The TCA62735AFLG is a charge pump type DC/DC Converter specially designed for constant current driving of White LED.

This IC can outputs LED current 120mA or more to 2.8-4.2V input.

This IC observes the power-supply voltage and the output voltage, and does an automatic change to the best of step up mode 1, 1.5 or 2 times. It is possible to prolong the battery longevity to its maximum.

This IC is especially for driving back light white LEDs in LCD of PDA, Cellular Phone, or Handy Terminal Equipment.

This device is Pb-free product.

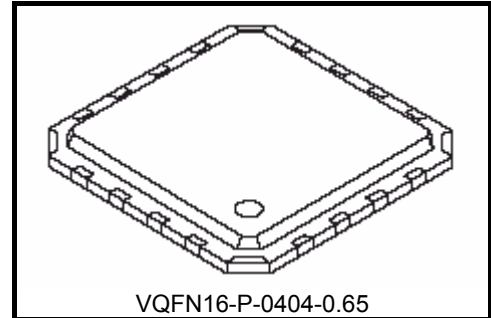

Weight: 0.016 g (Typ.)

### Characteristics

- Fabricating with CMOS Process
- Package : VQFN16-P-0404-0.65
- Input Voltage : 2.8V (Min)
- Switching Frequency : 1MHz (Typ.)
- Output Drive Current Capability : Greater than 120mA
- 4 Channels Built in Constant Sink Current Drivers (3 or 4 LEDs can be driven.)
- Sink Current Adjustment by External Resistance
- Soft Start Function
- Output Open Detection Function
- Thermal Shut Down Function (TSD)

**Pin Assignment (top view)**

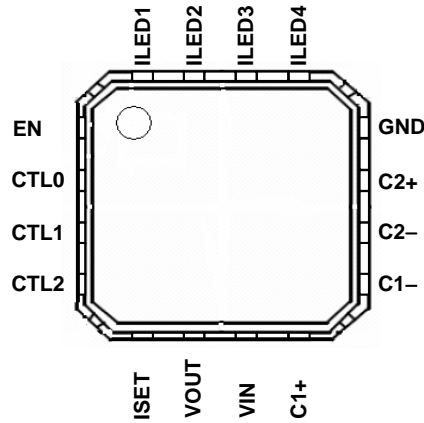

**Explanation of Terminals**

No	Symbol	Function
1	EN	Logic input terminal. (input a chip enable signal) EN = "H" → Operation mode, EN = "L" → Shutdown mode
2	CTL0	Logic input terminal. (Selection of an output number) Please refer to the truth table on page 15.
3	CTL1	
4	CTL2	
5	ISET	Resistance connection terminal for setting up output current.
6	VOUT	Output terminal.
7	VIN	Power supply terminal.
8	C1+	Capacitance connection terminal for charge pump.
9	C1-	
10	C2-	
11	C2+	
12	GND	GND terminal.
13	ILED4	Constant Sink Current Driver terminal.
14	ILED3	
15	ILED2	
16	ILED1	

Block Diagram

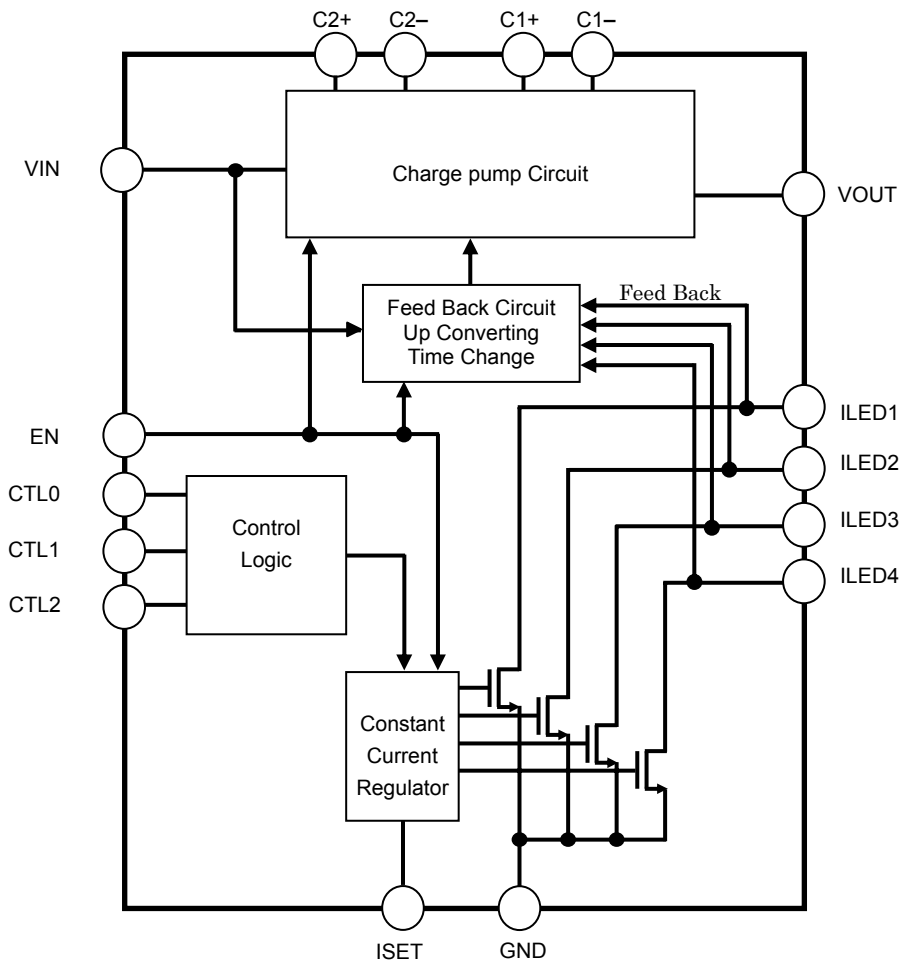

**I/O Equivalent Circuits**

1. ILED1~4

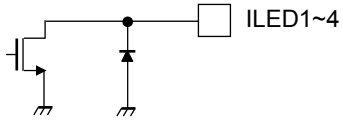

2. ISET

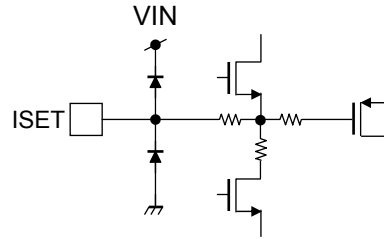

3. EN, CTL0, CTL1, CTL2

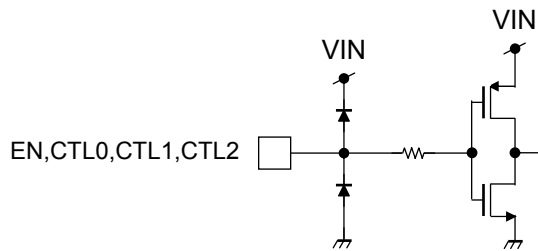

4. VOUT

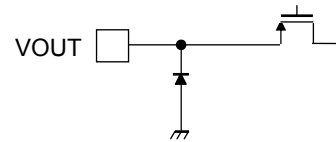

5. C1+, C2+

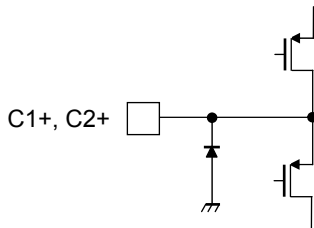

6. C1-

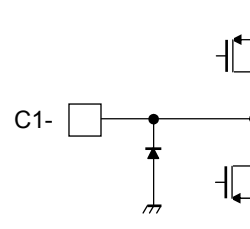

7. C2-

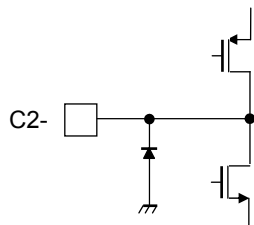

## Absolute Maximum Ratings ( $T_a = 25^\circ\text{C}$ if without notice)

Characteristics	Symbol	Ratings	Unit
Power Supply Voltage	$V_{IN}$	-0.3~+6.0	V
Input Voltage	$V_{IN(Logic)}$	-0.3~ $V_{IN}+0.3(*1)$	mA
Output Current	$I_{OUT}$	200	mA/ch
Operating Temperature	$T_{opr}$	-40~+85	$^\circ\text{C}$
Storage Temperature	$T_{stg}$	-55~+150	$^\circ\text{C}$
Junction Temperature	$T_j$	150	$^\circ\text{C}$

\*1 : please do not exceed 6V.

## Recommended Operating Condition ( $T_a=-40^\circ\text{C}$ to $85^\circ\text{C}$ if without notice)

Characteristics	Symbol	Test Condition	Min	Typ	Max	Unit
Power Supply	$V_{IN}$	-	2.8	-	4.2	V
Logic Input Voltage	$V_{IN(Logic)}$	EN,CTL0,CTL1,CTL2	0	-	$V_{IN}$	V
Capacitance for Charge Pump	$C_1, C_2$	-	0.8	1.0	2.2	$\mu\text{F}$
Capacitance for output	$C_{OUT}$	-	0.8	1.0	4.7	$\mu\text{F}$
Capacitance for input	$C_{IN}$	-	0.8	2.2	10.0	$\mu\text{F}$
R <sub>SET</sub> resistance	$R_{SET}$	-	8.2	12	47	k $\Omega$

## Electrical Characteristics

### DC-DC Regulator part ( $V_{IN}=3.6\text{V}$ , $T_a=25^\circ\text{C}$ , if it is not specified.)

Characteristics	Symbol	Test Circuits	Test Condition	Min	Typ	Max	Unit
Output Current Ability	$I_{OUT(MAX)}$	1	2 time up converting	120	-	-	mA
			1.5 time up converting	120	-	-	
			1 time up converting	120	-	-	
Consumption Current	$I_{IN(ON)}$	2	EN="H", $R_{SET}=47\text{k}\Omega$	-	1	2	mA
Stand By Consumption Current	$I_{IN(OFF)}$	2	EN="L"	-	0	1	$\mu\text{A}$
Logic Input Voltage	High	$V_{IH}$	3	EN, CTL0,CTL1,CTL2 $V_{IN}=2.8\text{V}\sim 4.2\text{V}$	$0.7V_{IN}$	-	V
	Low	$V_{IL}$	3	EN,CTL0,CTL1,CTL2 $V_{IN}=2.8\text{V}\sim 4.2\text{V}$	-	$0.3V_{IN}$	
Logic Input Current	$I_{leak}$	3	EN,CTL0,CTL1,CTL2	-	-	0.1	$\mu\text{A}$
Clock Frequency	$f_{OSC}$	4	-	-	1000	-	kHz
TOTAL R <sub>ON</sub>	$R_{ON}$	1	1.5 time up converting	-	5	10	$\Omega$
1X mode to 1.5X mode transition voltage	$V_{TRANS1X}$	4	LED $V_F=3.6\text{V}$ , $R_{SET}=12\text{k}\Omega$ $V_{IN}$ falling	-	4.0	-	V

### Constant Current Driver part ( $V_{IN}=3.6\text{V}$ , $T_a=25^\circ\text{C}$ , if it is not specified.)

Characteristics	Symbol	Test Circuits	Test Condition	Min	Typ	Max	Unit
Constant Current Drive Setting	$I_{LED1-4}$	5	$R_{SET}=47\text{k}\Omega$	-	5.1	-	mA
			$R_{SET}=12\text{k}\Omega$	-	19.6	-	
			$R_{SET}=8.2\text{k}\Omega$	-	28	-	
ISET Terminal Output Voltage	$V_{SET}$	5	$R_{SET}=8.2\text{k}\Omega$	-	0.61	-	V
Constant Current Accuracy	Between Chs	$ I_{LED-LED-ERR} $	5	-	2.5	-	%
	Between ICs	$ I_{LED-ERR} $	5	-	5	-	%
Constant Sink Current Supply Voltage Regulation	$ \Delta I_{LED} $	5	$V_{IN}=3.6\text{V}$ center, $V_{IN}=2.8\sim 4.2\text{V}$ $I_{OUT}=80\text{mA}$	-	1	-	%
Output leakage current	$I_{LEAK1-4}$	5	EN="L"	-	-	1	$\mu\text{A}$

## Test Circuits

Test Circuit1: Output Current Ability, TOTAL  $R_{ON}$

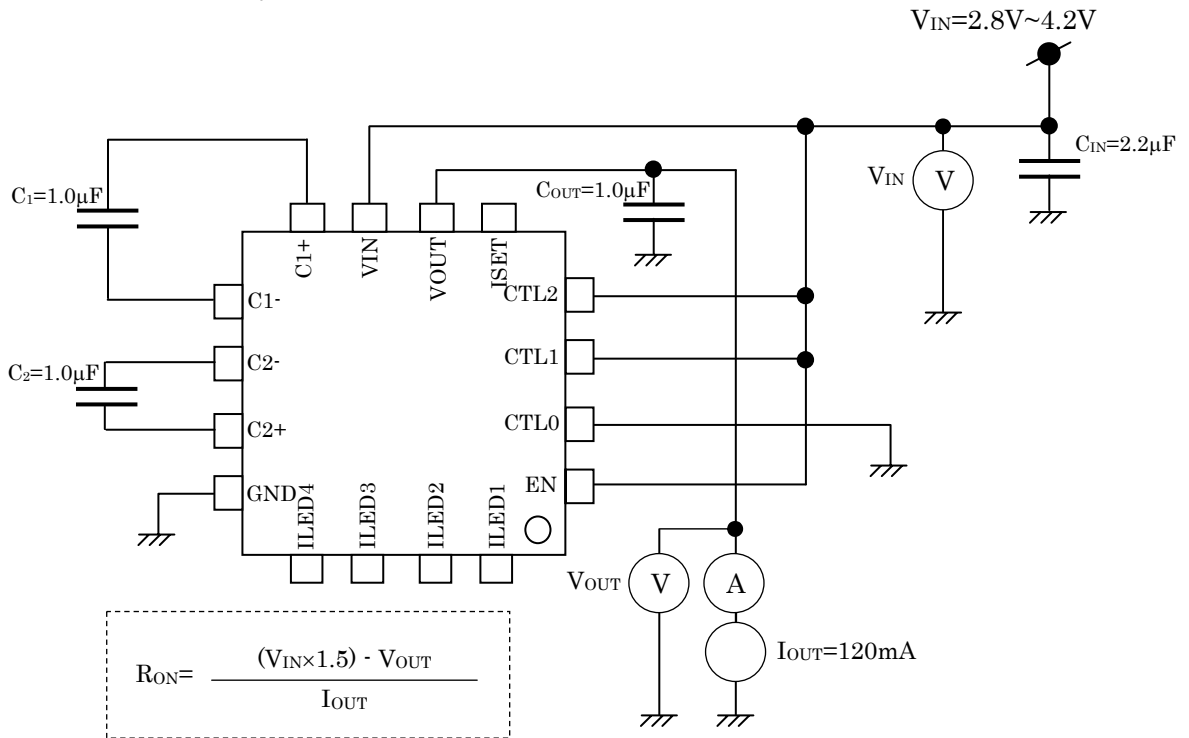

Test Circuit2: Consumption Current, Stand By Consumption Current

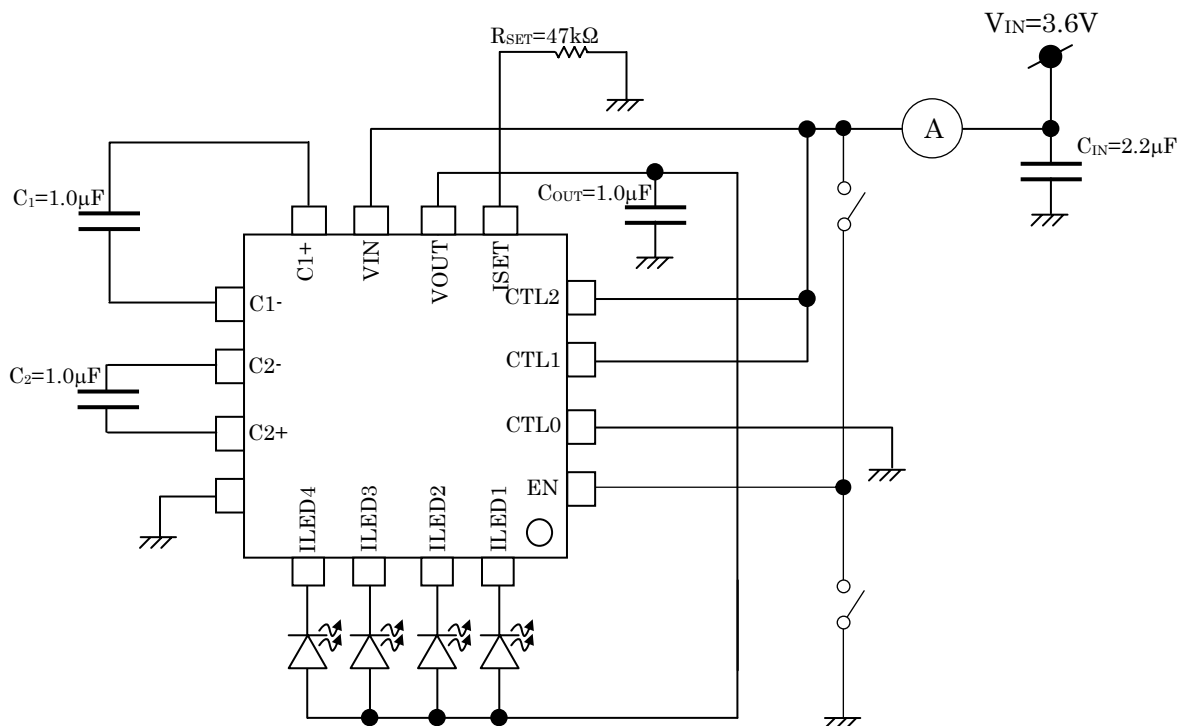

Test Circuit3: Logic Input Voltage, Logic Input Current

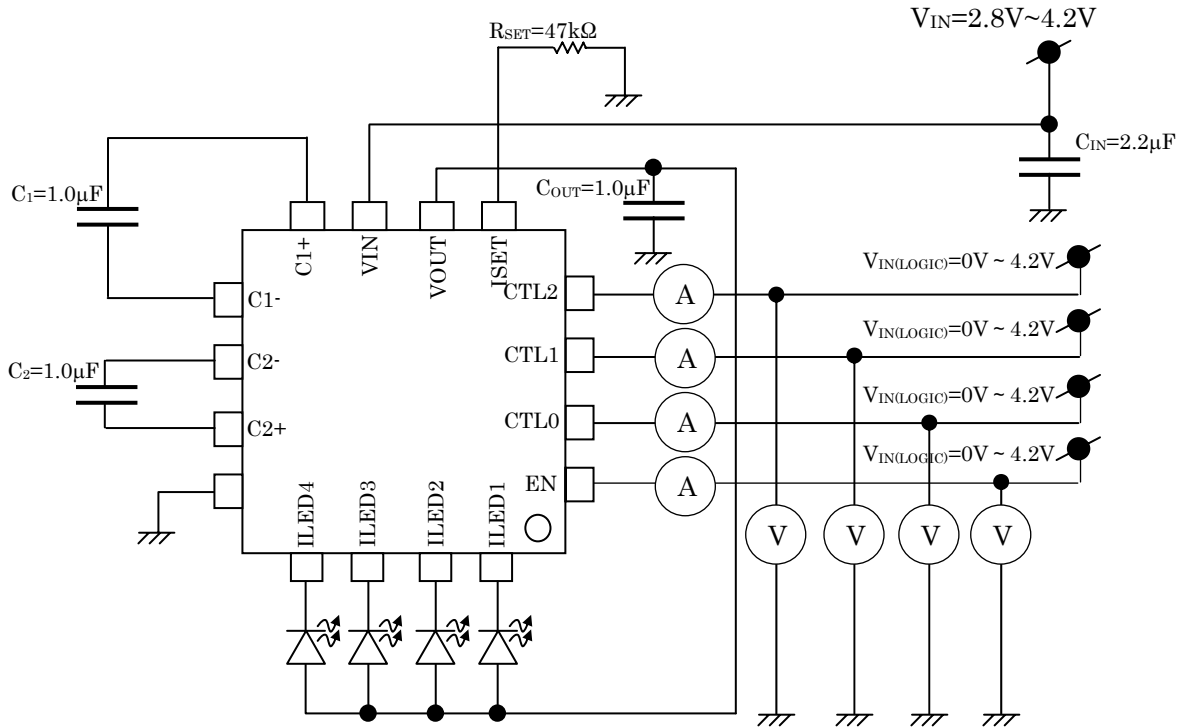

Test Circuit4: Clock Frequency, 1X mode to 1.5X mode transition voltage

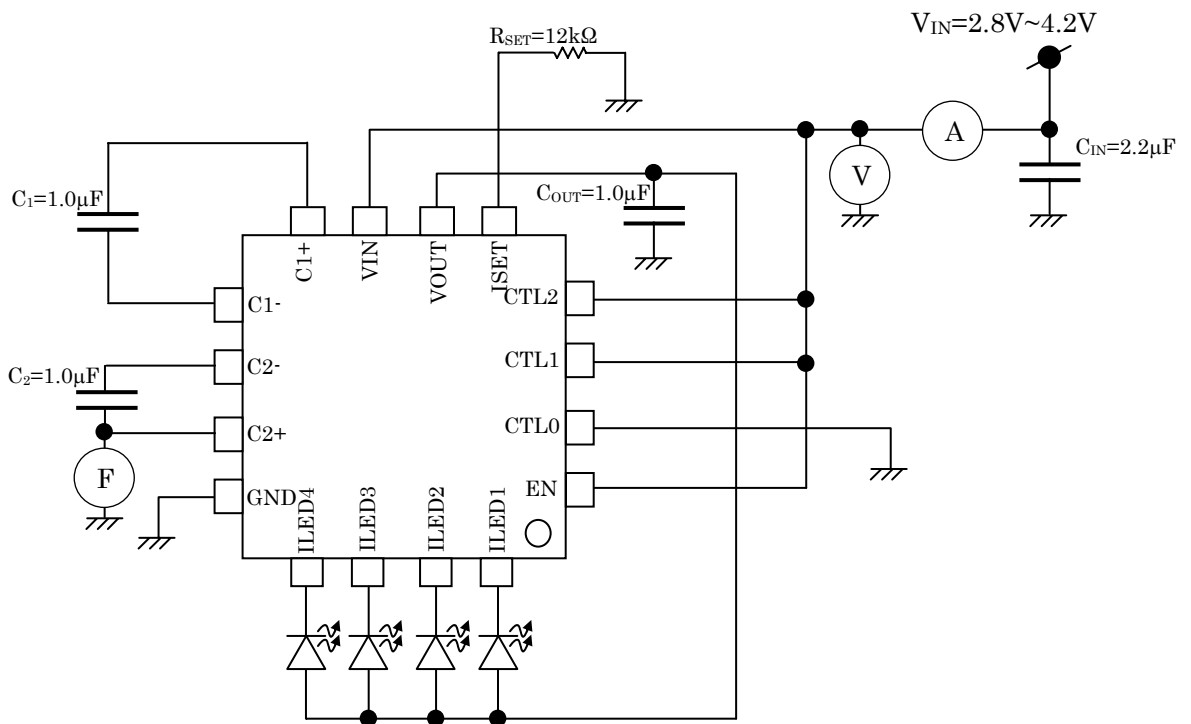

Test Circuit5: Constant Current Drive Setting, ISET Terminal Output Voltage, Constant Current Accuracy  
 Constant Sink Current Supply Voltage Regulation, Output leakage current

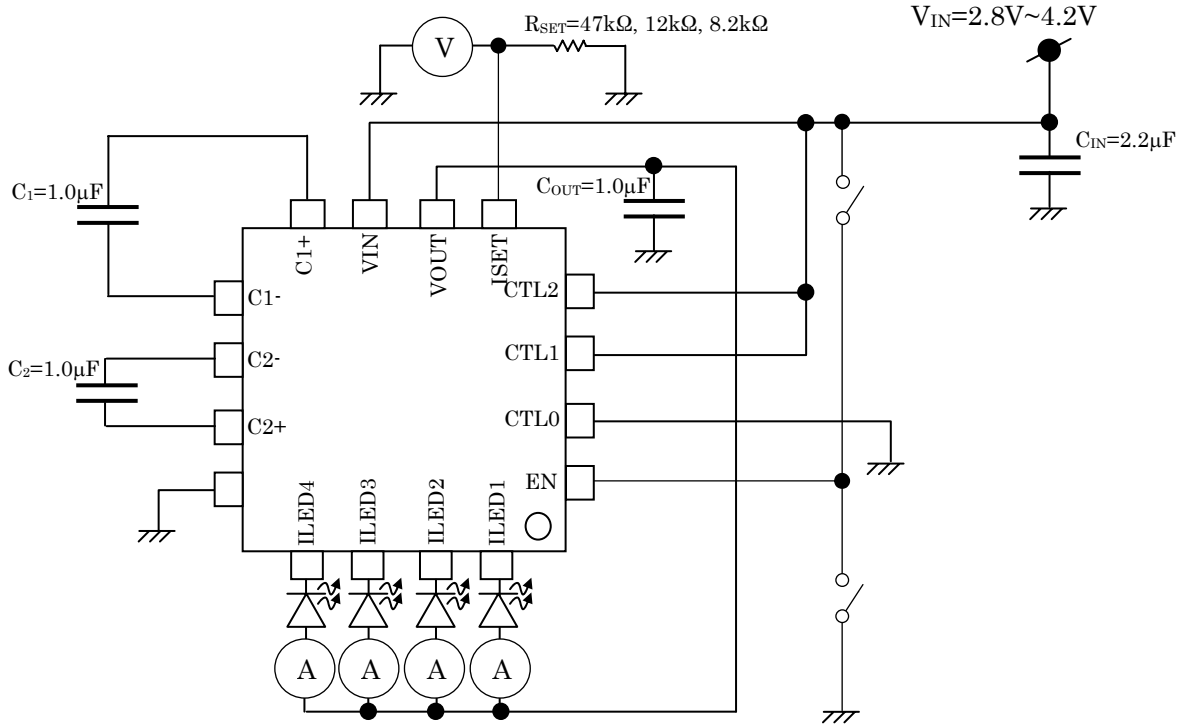



## Reference data

\*This data is provided for reference only. Thorough evaluation and testing should be implemented when designing your application's mass production design.

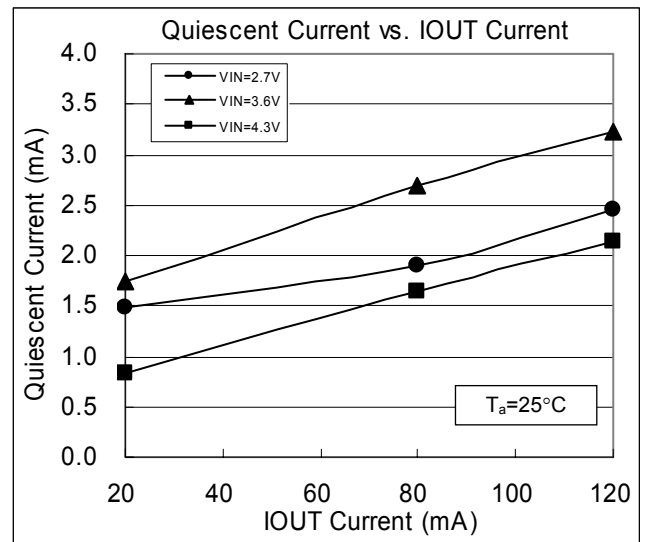
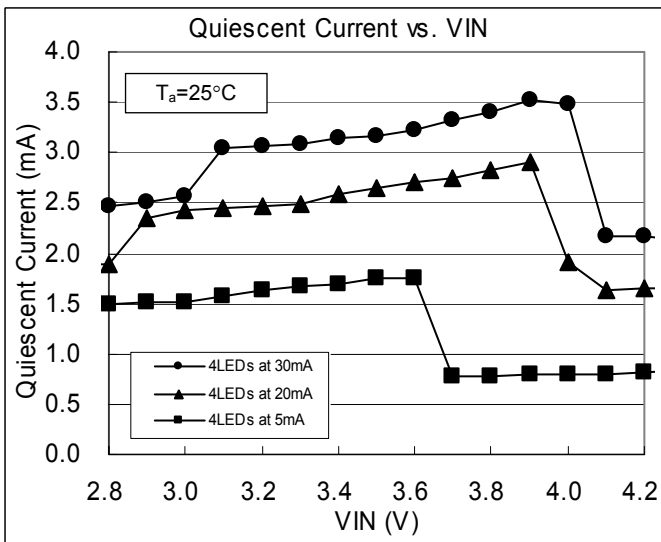
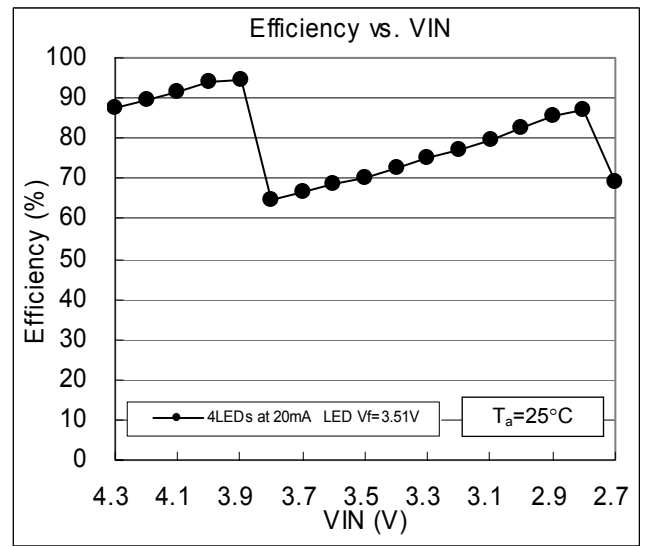
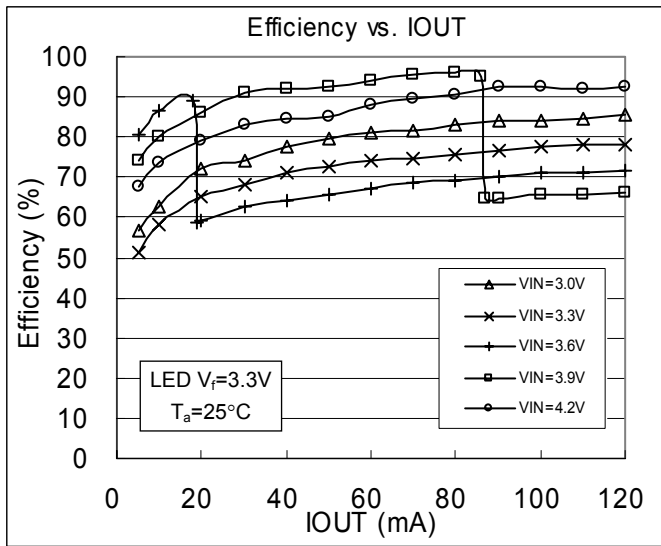

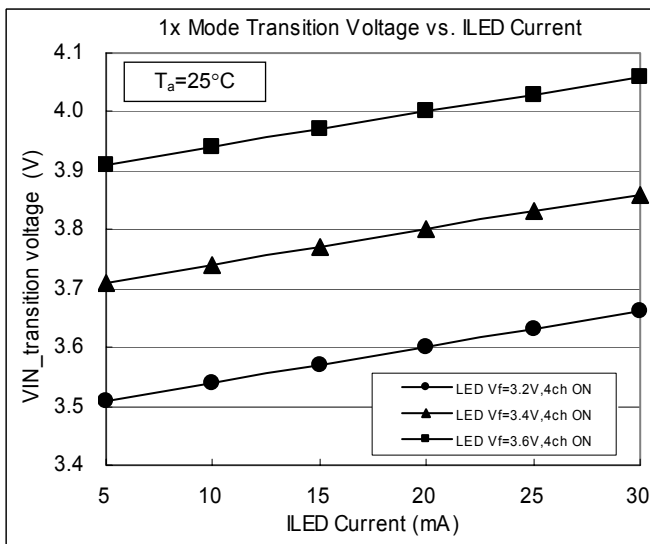
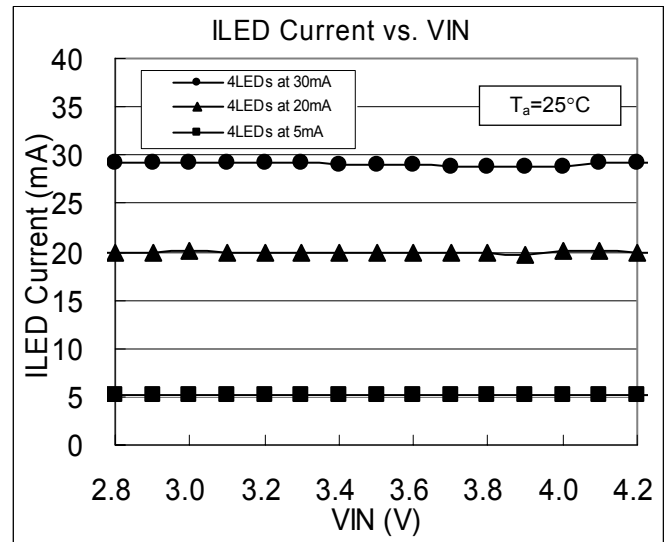
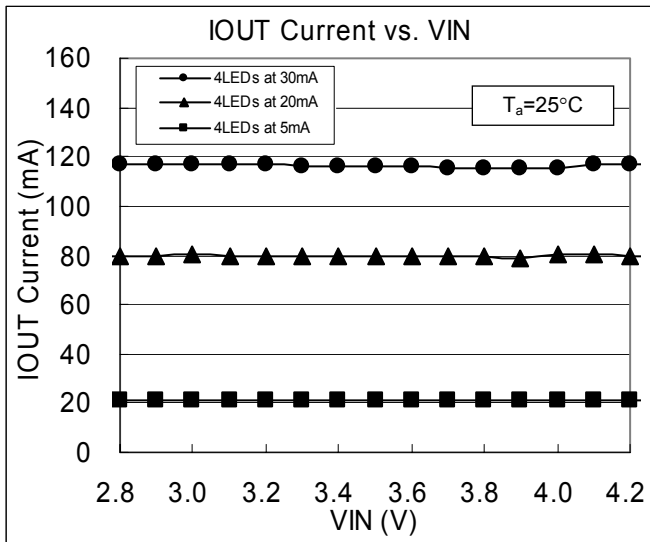

## Evaluation Circuit

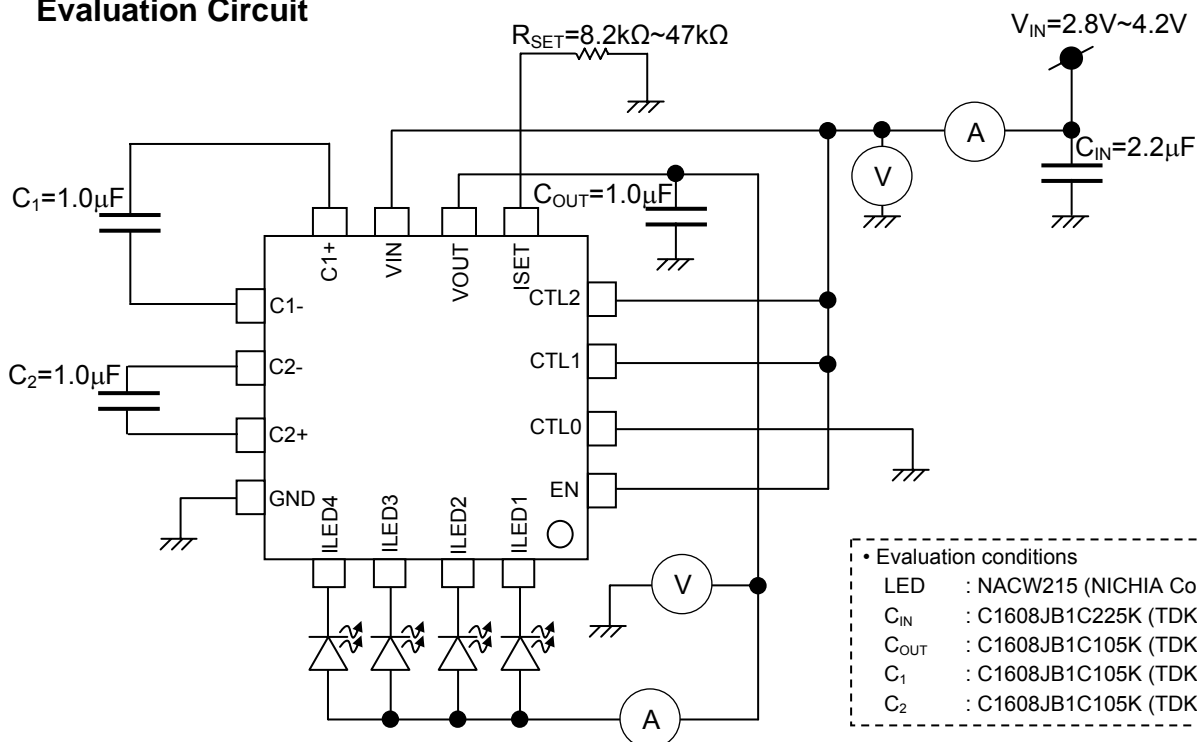

**Method of setting I<sub>LED</sub>**

The current of the terminal I<sub>LED</sub>1 to 4 is set by resistance R<sub>SET</sub> connected with the terminal ISET. I<sub>LED</sub> can be set according to the next expression.

$$I_{LED}[mA] = \frac{400 \times 0.61[V]}{R_{SET}[k\Omega]}$$

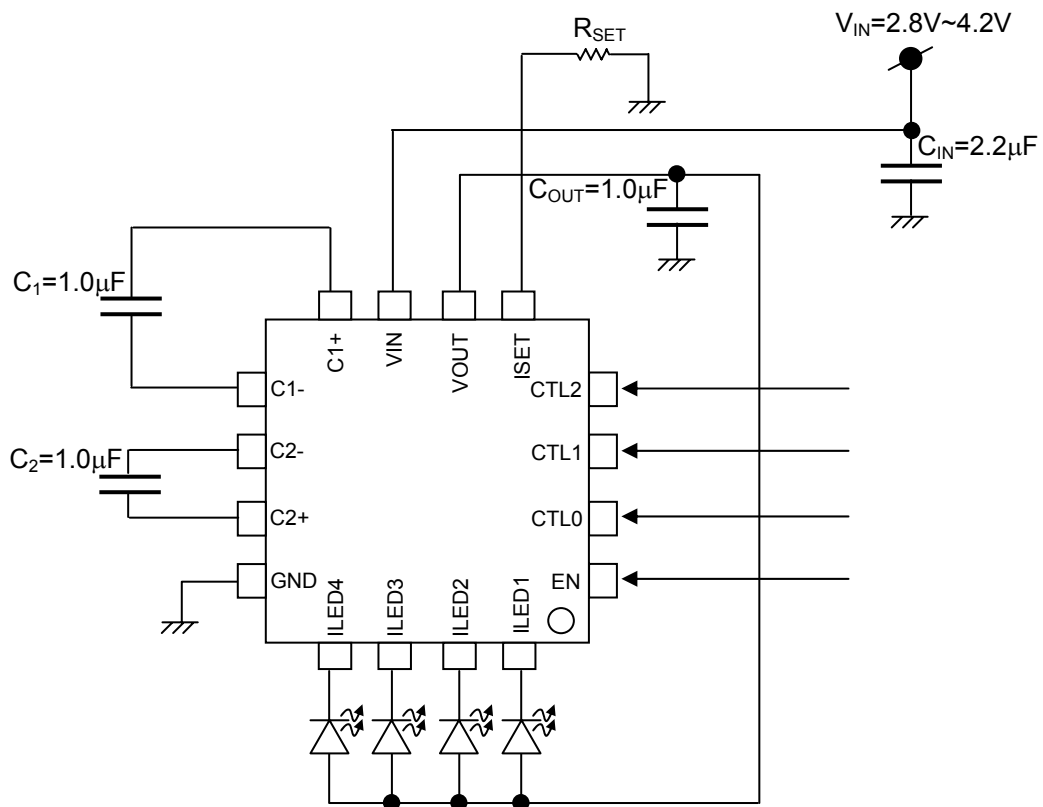
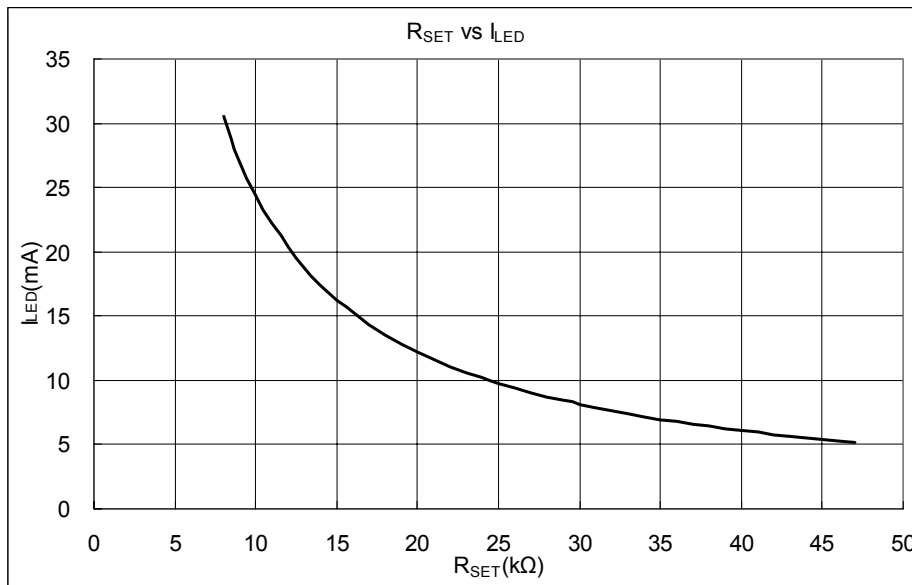

## Method of Current Dimming control

### 1) Input PWM signal to SHDN terminal

$I_{LED}$  can be set according to the next expression.

$$I_{LED}[mA] = \frac{0.61[V] \times 400 \times \text{ON Duty}[\%]}{R_{SET}[k\Omega]}$$

$f_{PWM}$  will recommend 100Hz.

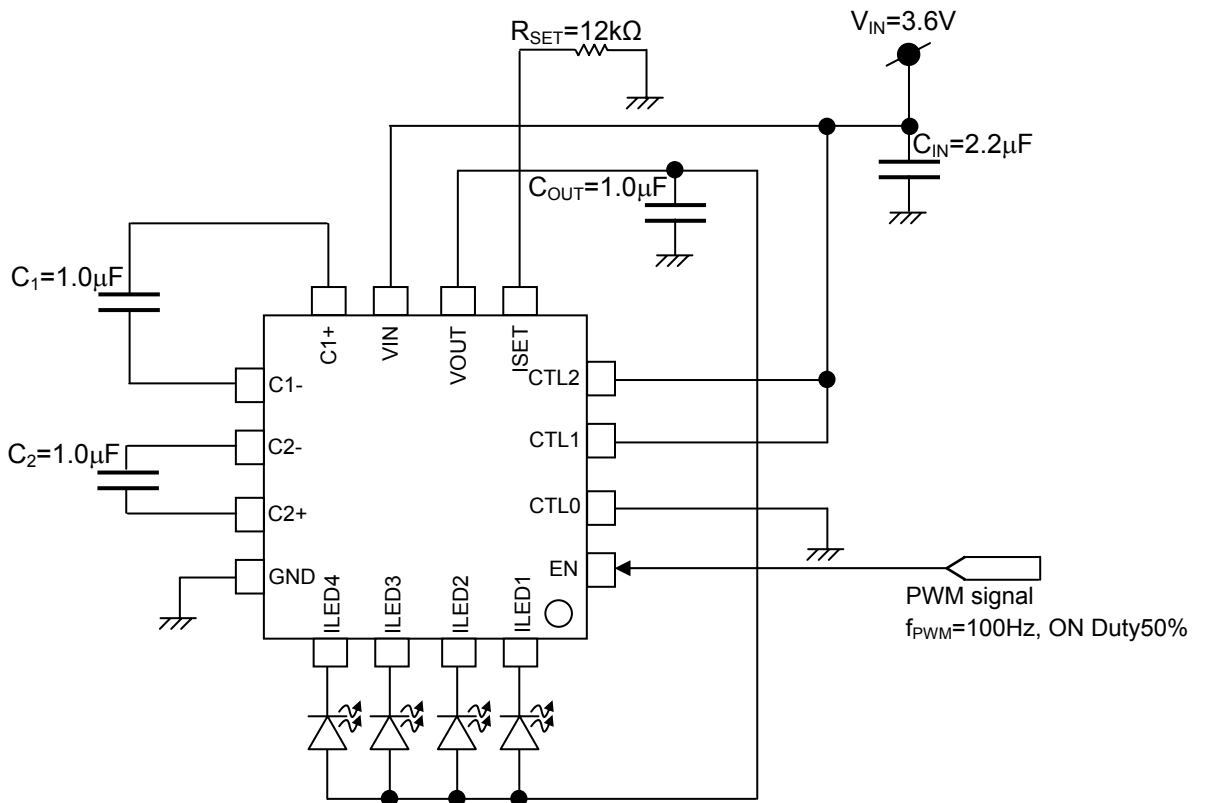
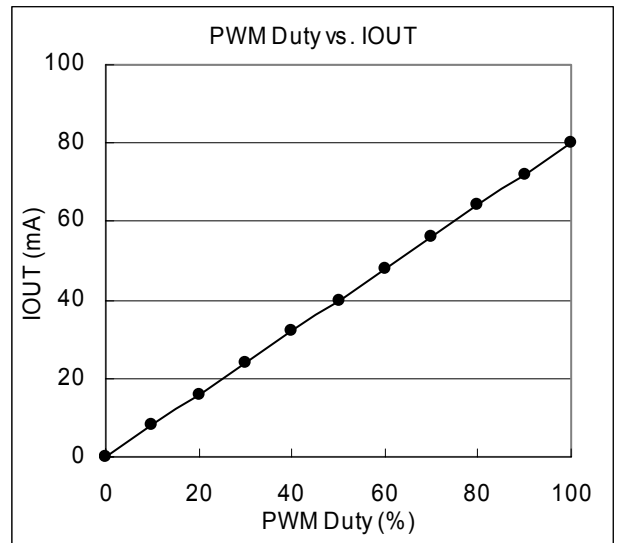
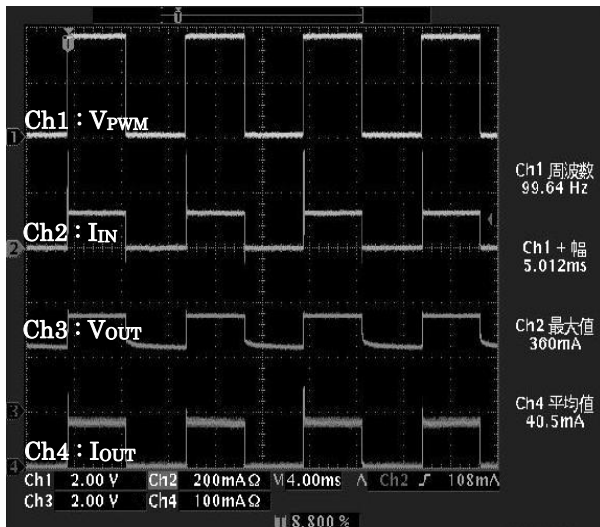

\*In this PWM control operation, This IC repeats ON/OFF. In this result, rush current is occur when ON timing with supplying charge to  $C_{OUT}$ . Please note it.

## 2) Input analog voltage to ISET terminal

### 1. Precondition

- Please set the range of the analog voltage input by 0 to 0.61V.

### 2. The maximum current is defined as $\alpha$ mA.

$$\alpha[\text{mA}] = 0.61[\text{V}] \times \frac{R_1[\text{k}\Omega] + R_2[\text{k}\Omega]}{R_1[\text{k}\Omega] \times R_2[\text{k}\Omega]} \times 400$$

### 3. A minimum current is defined as $\beta$ mA.

$$\beta[\text{mA}] = 0.61[\text{V}] \times \frac{1}{R_2[\text{k}\Omega]} \times 400$$

### 4. $I_{\text{LED}}$ can be set according to the next expression.

$$I_{\text{LED}}[\text{mA}] = V_{\text{ADJ}}[\text{V}] \times \frac{\beta[\text{mA}] - \alpha[\text{mA}]}{0.61[\text{V}]} + \alpha[\text{mA}]$$

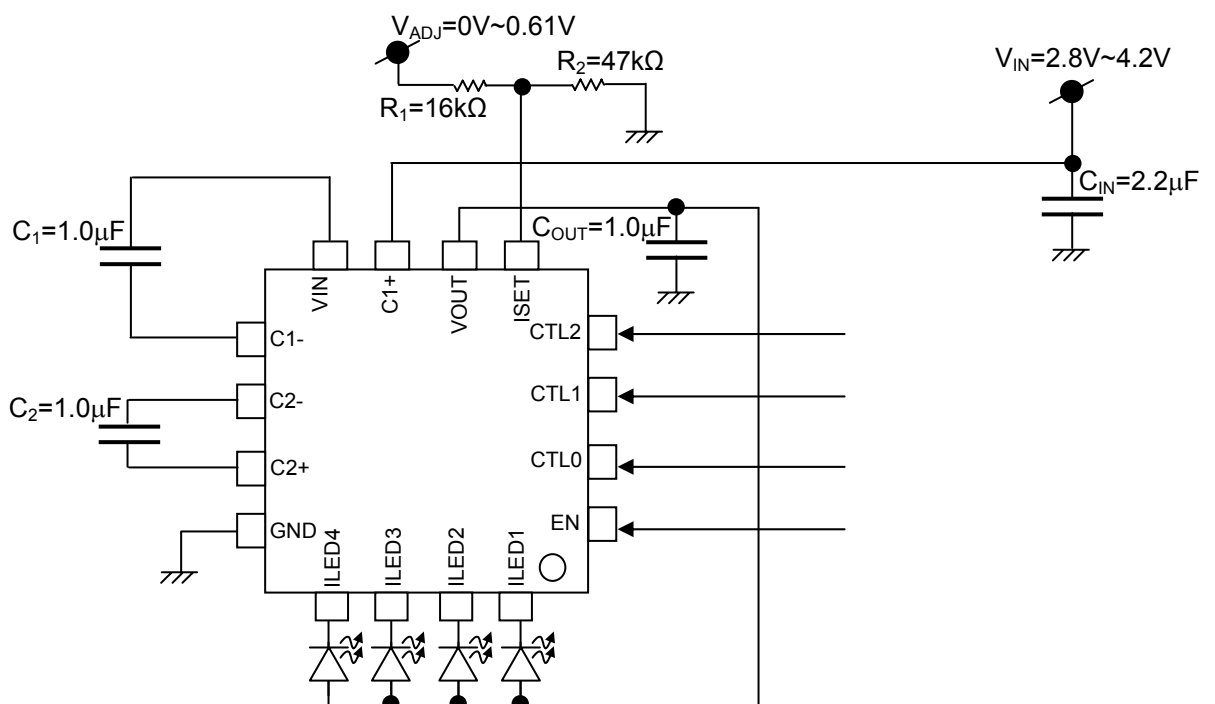
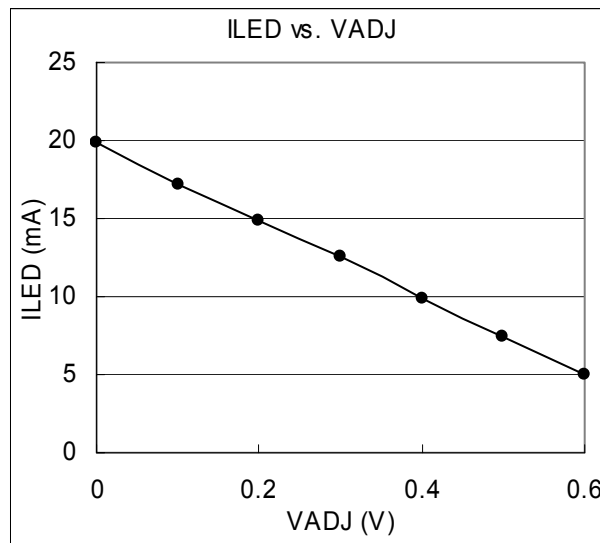

\*This method is without repeating IC ON/OFF, and no need to consider holding rash current.

**3) Input Logic signal**

User can adjust  $I_{LED}$  with Logic signal input as indicated in recommended circuit. The Resistor connected the ON-State Nch MOS Drain and  $R_{SET}$  determines  $I_{LED}$ .

$I_{LED}$  can be set according to the next expression.

$$I_{LED}[mA] = \frac{400 \times 0.61[V]}{R[k\Omega]}$$

About combined resistance  $R[k\Omega]$

M1	M2	$R[k\Omega]$
ON	ON	$\frac{R_{SET}[k\Omega] \times R_1[k\Omega] \times R_2[k\Omega]}{R_1[k\Omega] \times R_{SET}[k\Omega] + R_2[k\Omega] \times R_{SET}[k\Omega] + R_1[k\Omega] \times R_2[k\Omega]}$
ON	OFF	$\frac{R_{SET}[k\Omega] \times R_1[k\Omega]}{R_{SET}[k\Omega] + R_1[k\Omega]}$
OFF	ON	$\frac{R_{SET}[k\Omega] \times R_2[k\Omega]}{R_{SET}[k\Omega] + R_2[k\Omega]}$
OFF	OFF	$R_{SET}[k\Omega]$

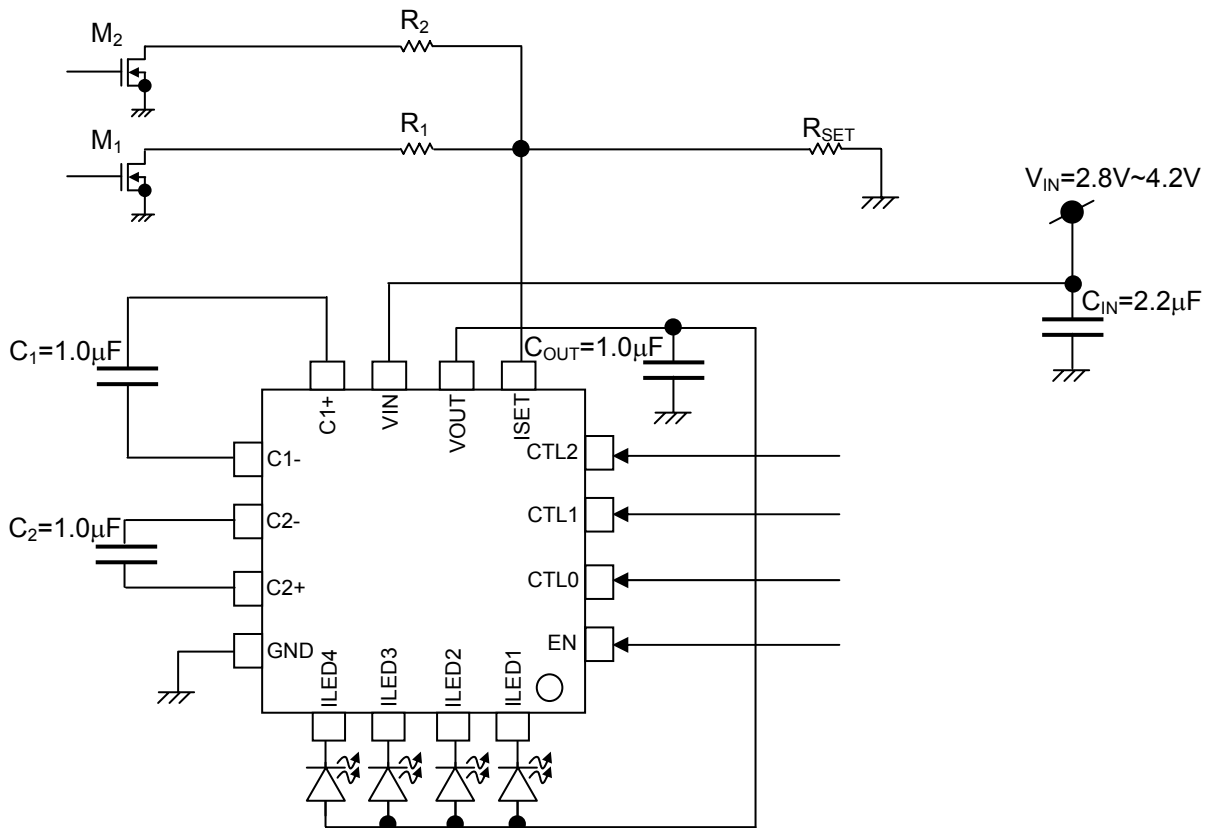

\*This method is without repeating IC ON/OFF, and no need to consider holding rash current.

## Selection of an output number by CTL0, CTL1, and CTL2 Terminal

Truth Table

Input				Output			
CTL2	CTL1	CTL0	EN	ILED4	ILED3	ILED2	ILED1
L	L	L	H	Please do not set it.			
L	L	H	H				
L	H	L	H				
L	H	H	H				
H	L	L	H				
H	L	H	H	OFF	ON	ON	ON
H	H	L	H	ON	ON	ON	ON
H	H	H	H	OFF	OFF	OFF	OFF
L	L	L	L	OFF	OFF	OFF	OFF
L	L	H	L	OFF	OFF	OFF	OFF
L	H	L	L	OFF	OFF	OFF	OFF
L	H	H	L	OFF	OFF	OFF	OFF
H	L	L	L	OFF	OFF	OFF	OFF
H	L	H	L	OFF	OFF	OFF	OFF
H	H	L	L	OFF	OFF	OFF	OFF
H	H	H	L	OFF	OFF	OFF	OFF

### Attention in use

#### \*Soft Start Function

This device is integrated Soft start function. When the power supply is ON or output is started to operate, the transition time is controlled in order to decrease the rush current.

(Reference data: The output voltage is time 200μs of made from 0 to 4.0V at the  $V_{IN}=2.8V$  time.)

#### \*Inrush Current of Input Current

The inrush current flows when start-up and mode switching.

(Reference data: Inrush current at CE1/CE2="L" to "H" is 500mA.)

#### \*Thermal Shut Down Function

This device has Thermal Shutdown Function to protect from thermal damage when the output is shorted.

The temperature to operate this function is set around from 140 to 160°C. (This is not guaranteed Value.)

#### \*The Selection of Capacitor for Charge Pump, Input and Output

The input capacitor is effective to decrease the impedance of power supply and also input current is averaged.

The input capacitor should be selected by impedance of power supply, it is better to choose with lower ESR (Equivalent Series Resistor). (i.e. ceramic capacitor etc.) Regarding to the capacitance values, it is recommended to choose in the range from 0.8 μF to 10 μF, however larger than 2.2 μF should be better.

The output capacitor is effective to decrease the ripple noise of the output line. Also, it is better to choose the capacitor.) Regarding to the capacitance values, it is recommended to choose in the range from 0.8 μF to 4.7 μF, however larger than 1.0 μF should be better.

The capacitor for charge pump operation is also selected the capacitor with low ESR. ) Regarding to the capacitance values, it is recommended to choose in the range from 0.8 μF to 2.2 μF, however larger than 1.0 μF should be better.

**Package Dimensions**

VQFN16-P-0404-0.65

Unit : mm

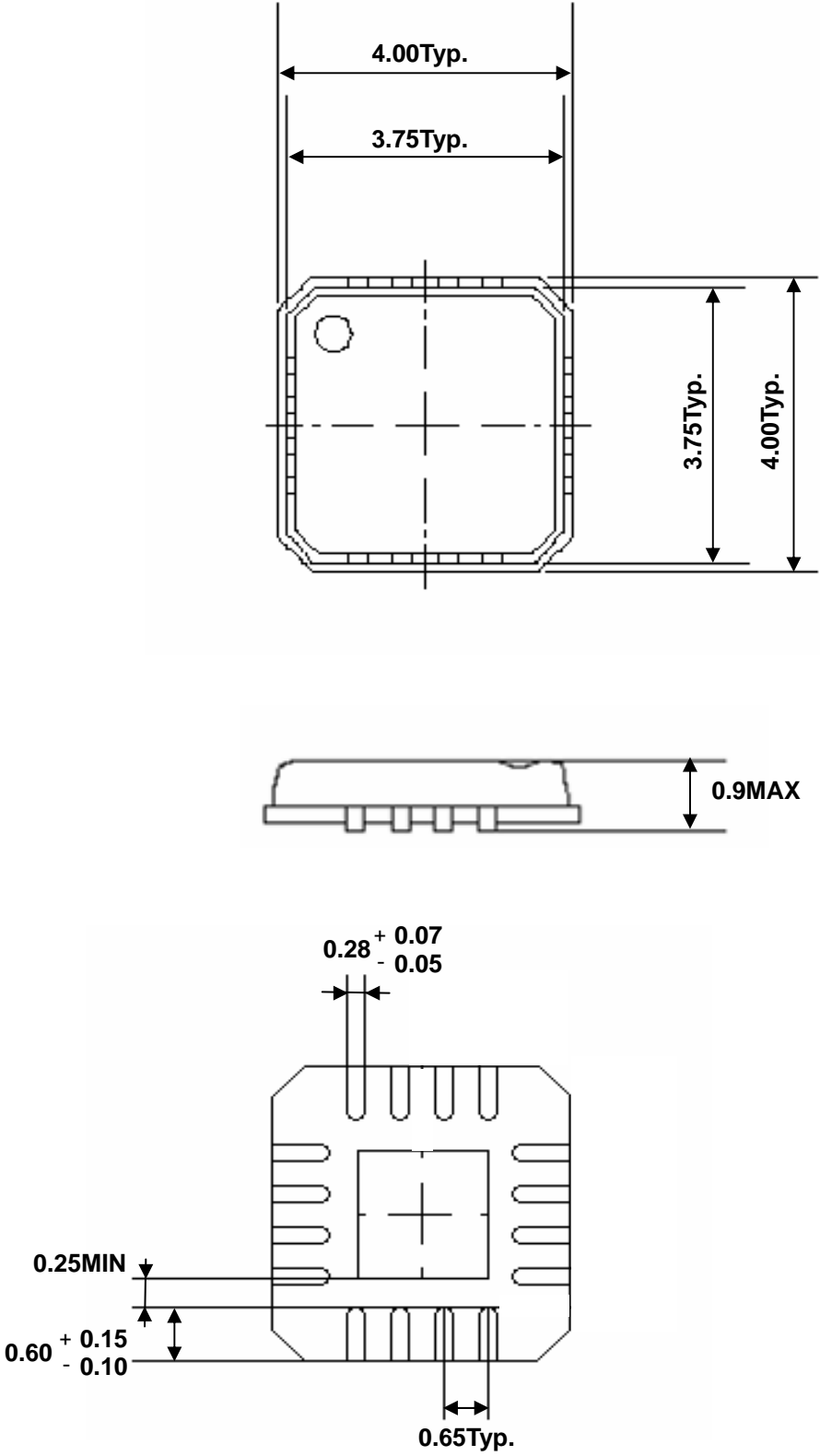

Weight: 0.016 g (Typ.)



## Notes on Contents

### 1. Block Diagrams

Some of the functional blocks, circuits, or constants in the block diagram may be omitted or simplified for explanatory purposes.

### 2. Equivalent Circuits

The equivalent circuit diagrams may be simplified or some parts of them may be omitted for explanatory purposes.

### 3. Timing Charts

Timing charts may be simplified for explanatory purposes.

### 4. Application Circuits

The application circuits shown in this document are provided for reference purposes only. Thorough evaluation is required, especially at the mass production design stage.

Toshiba does not grant any license to any industrial property rights by providing these examples of application circuits.

### 5. Test Circuits

Components in the test circuits are used only to obtain and confirm the device characteristics. These components and circuits are not guaranteed to prevent malfunction or failure from occurring in the application equipment.

## IC Usage Considerations

### Notes on handling of ICs

- [1] The absolute maximum ratings of a semiconductor device are a set of ratings that must not be exceeded, even for a moment. Do not exceed any of these ratings.  
Exceeding the rating(s) may cause the device breakdown, damage or deterioration, and may result injury by explosion or combustion.
- [2] Use an appropriate power supply fuse to ensure that a large current does not continuously flow in case of over current and/or IC failure. The IC will fully break down when used under conditions that exceed its absolute maximum ratings, when the wiring is routed improperly or when an abnormal pulse noise occurs from the wiring or load, causing a large current to continuously flow and the breakdown can lead smoke or ignition. To minimize the effects of the flow of a large current in case of breakdown, appropriate settings, such as fuse capacity, fusing time and insertion circuit location, are required.
- [3] If your design includes an inductive load such as a motor coil, incorporate a protection circuit into the design to prevent device malfunction or breakdown caused by the current resulting from the inrush current at power ON or the negative current resulting from the back electromotive force at power OFF. IC breakdown may cause injury, smoke or ignition.  
Use a stable power supply with ICs with built-in protection functions. If the power supply is unstable, the protection function may not operate, causing IC breakdown. IC breakdown may cause injury, smoke or ignition.
- [4] Do not insert devices in the wrong orientation or incorrectly.  
Make sure that the positive and negative terminals of power supplies are connected properly.  
Otherwise, the current or power consumption may exceed the absolute maximum rating, and exceeding the rating(s) may cause the device breakdown, damage or deterioration, and may result injury by explosion or combustion.  
In addition, do not use any device that is applied the current with inserting in the wrong orientation or incorrectly even just one time.
- [5] Carefully select external components (such as inputs and negative feedback capacitors) and load components (such as speakers), for example, power amp and regulator.  
If there is a large amount of leakage current such as input or negative feedback condenser, the IC output DC voltage will increase. If this output voltage is connected to a speaker with low input withstand voltage, overcurrent or IC failure can cause smoke or ignition. (The over current can cause smoke or ignition from the IC itself.) In particular, please pay attention when using a Bridge Tied Load (BTL) connection type IC that inputs output DC voltage to a speaker directly.

About solderability, following conditions were confirmed

- Solderability

- (1) Use of Sn-37Pb solder Bath

- solder bath temperature = 230°C
    - dipping time = 5 seconds
    - the number of times = once
    - use of R-type flux

- (2) Use of Sn-3.0Ag-0.5Cu solder Bath

- solder bath temperature = 245°C
    - dipping time = 5 seconds
    - the number of times = once
    - use of R-type flux

## RESTRICTIONS ON PRODUCT USE

030619EBA

- The information contained herein is subject to change without notice.
- The information contained herein is presented only as a guide for the applications of our products. No responsibility is assumed by TOSHIBA for any infringements of patents or other rights of the third parties which may result from its use. No license is granted by implication or otherwise under any patent or patent rights of TOSHIBA or others.
- TOSHIBA is continually working to improve the quality and reliability of its products. Nevertheless, semiconductor devices in general can malfunction or fail due to their inherent electrical sensitivity and vulnerability to physical stress. It is the responsibility of the buyer, when utilizing TOSHIBA products, to comply with the standards of safety in making a safe design for the entire system, and to avoid situations in which a malfunction or failure of such TOSHIBA products could cause loss of human life, bodily injury or damage to property.  
In developing your designs, please ensure that TOSHIBA products are used within specified operating ranges as set forth in the most recent TOSHIBA products specifications. Also, please keep in mind the precautions and conditions set forth in the "Handling Guide for Semiconductor Devices," or "TOSHIBA Semiconductor Reliability Handbook" etc..
- The TOSHIBA products listed in this document are intended for usage in general electronics applications (computer, personal equipment, office equipment, measuring equipment, industrial robotics, domestic appliances, etc.). These TOSHIBA products are neither intended nor warranted for usage in equipment that requires extraordinarily high quality and/or reliability or a malfunction or failure of which may cause loss of human life or bodily injury ("Unintended Usage"). Unintended Usage include atomic energy control instruments, airplane or spaceship instruments, transportation instruments, traffic signal instruments, combustion control instruments, medical instruments, all types of safety devices, etc.. Unintended Usage of TOSHIBA products listed in this document shall be made at the customer's own risk.
- The products described in this document are subject to the foreign exchange and foreign trade laws.
- TOSHIBA products should not be embedded to the downstream products which are prohibited to be produced and sold, under any law and regulations.