



PRELIMINARY

CCD VERTICAL DRIVER

■ **FEATURES**

- 3 levels of output voltage, 15V, 0V and -8.5V
- 3.3V / 5V input voltage
- Build in a 15V voltage amplifier circuit

■ **DESCRIPTION**

AA87221AP is a vertical driver with 3 levels of output voltage processed in a standard CMOS.

■ **PIN ASSIGNMENT & BLOCK DIAGRAM**

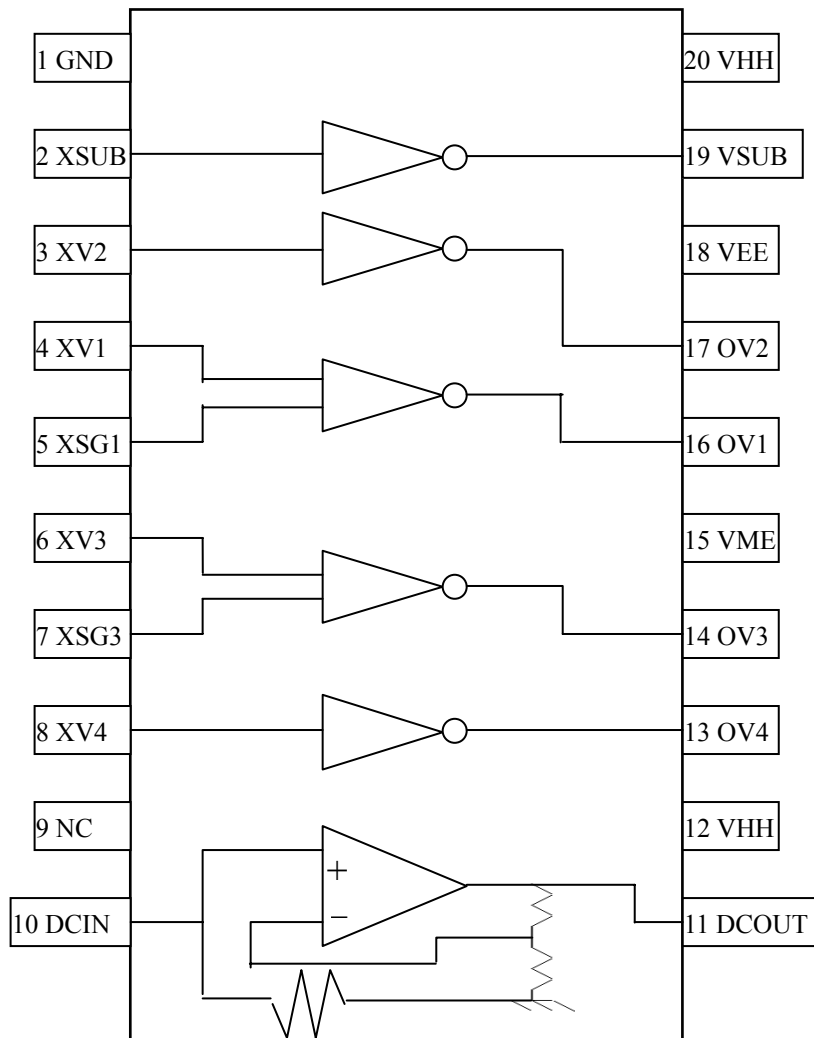



PRELIMINARY

CCD VERTICAL DRIVER

■ **PIN DESCRIPTION**

Symbol	Pin No.	Type	Name & Function
POWER			
VHH	12, 20	-	+15V power supply pin
GND	1	-	Ground pin
VEE	18	-	-8.5V power supply pin
VME	15	-	Power pin(0v)
INPUT SIGNAL			
XSUB	2	I	Input signal pin --control VSUB
XV1	4	I	Input signal pin --control OV1
XV2	3	I	Input signal pin --control OV2
XV3	6	I	Input signal pin --control OV3
XV4	8	I	Input signal pin --control OV4
XSG1	5	I	Input signal pin --control OV1
XSG3	7	I	Input signal pin --control OV3
DCIN	10	I	Voltage amplifier input signal pin
OUTPUT SIGNAL			
VSUB	19	O	Output signal pin --2 level, VEE & VHH
OV1	16	O	Output signal pin --3 level, VEE, VHH & VME
OV2	17	O	Output signal pin --2 level, VEE & VME
OV3	14	O	Output signal pin --3 level, VEE, VHH & VME
OV4	13	O	Output signal pin --2 level, VEE & VME
DCOUT	12	O	Voltage amplifier output signal pin



PRELIMINARY

CCD VERTICAL DRIVER

■ **ABSOLUTE MAXIMUM RATINGS** (See NOTE)

Parameter	Symbol	Rating			UNIT
		MIN	TYP	MAX	
Supply Voltage	VEE	-10		0	V
	VHH	-0.3		VEE+30	V
	VME	VEE-0.3		3	V
Input Voltage	VI	-0.3		VHH+0.3	V
Output Voltage	OV1, OV3, VSUB	VEE-0.3		VHH+0.3	V
	OV2, OV4	VEE-0.3		VME+0.3	V
Voltage-Amplifier Output Current	Idcout	-5		5	mA
Operating Ambient Temperature	Ta	-25		85	
Storage Temperature	Ts	-45		125	

NOTE: Stress above those listed under “Absolute Maximum Rating” may cause permanent damage to the device. This is a stress rating only and functional operation of the device at these or any other conditions above those indicated in the operational section of this specification is not implied. Exposure to absolute maximum rating conditions for the extended periods of time may affect device reliability.

■ **LOGIC TRUTH TABLE**

INPUT				OUTPUT		
XV1, 3	XSG1, 3	XV2, 4	XSUB	OV1, 3	OV2, 4	VSUB
L	L	X	X	VHH	X	X
H	L	X	X	Z	X	X
L	H	X	X	VME	X	X
H	H	X	X	VEE	X	X
X	X	L	X	X	VME	X
X	X	H	X	X	VEE	X
X	X	X	L	X	X	VHH
X	X	X	H	X	X	VEE



PRELIMINARY

CCD VERTICAL DRIVER

■ **DC CHARACTERISTICS** (V_{HH}=15, V_{ME}=GND, V_{EE}=-8.5V; T_a = 25)

Parameter	Symbol	Value			Unit	Condition
		Min	Typ	Max		
Power Supply	V _{HH}	14.5	15	15.5	V	
	V _{EE}	-9.5	-8.5	-7.5	V	
Supply Current	I _{HH}		2.4	6	mA	(*1)
	I _{EE}	-8	-4.2		mA	
	I _{ME}		0.6	2.5	mA	
Input Voltage	V _{IH}	2.3			V	
	V _{IL}			1.3		
Input Current	I _I	-1	0	1	uA	V _{IN} =0~5V (*3)
	I _{DCIN}	70	100	140	uA	V _{DCIN} =1.0V
Output Current	I _{OL}	24	30		mA	OV1~4=-8.0V
	I _{OM1}		-18	-25	mA	OV1~4=-0.5V
	I _{OM2}		18	25	mA	OV1,3=0.5V
	I _{OH}		-15	-25	mA	OV1,3=14.5V
	I _{OSL}		21	30	mA	V _{SUB} =-8.0V
	I _{OSH}		-10	-30	mA	V _{SUB} =14.5V
OP-AMP Gain	G		4.3			I _{OUT} =-200/100uA
Gain Variation	G	-3		3	%	T _a =-20~75 (*2) I _{out} =-200/100uA; V _{DCIN} =0.5~3.5V

(*1) Refer the measurement circuit. Shutter speed: 1/40us

(*2) Refer the characteristic of OP-AMP

(*3) XV1~ 4, XSG1, 3, XSUB pins

PRELIMINARY

CCD VERTICAL DRIVER

■ **MEASUREMENT CIRCUIT**

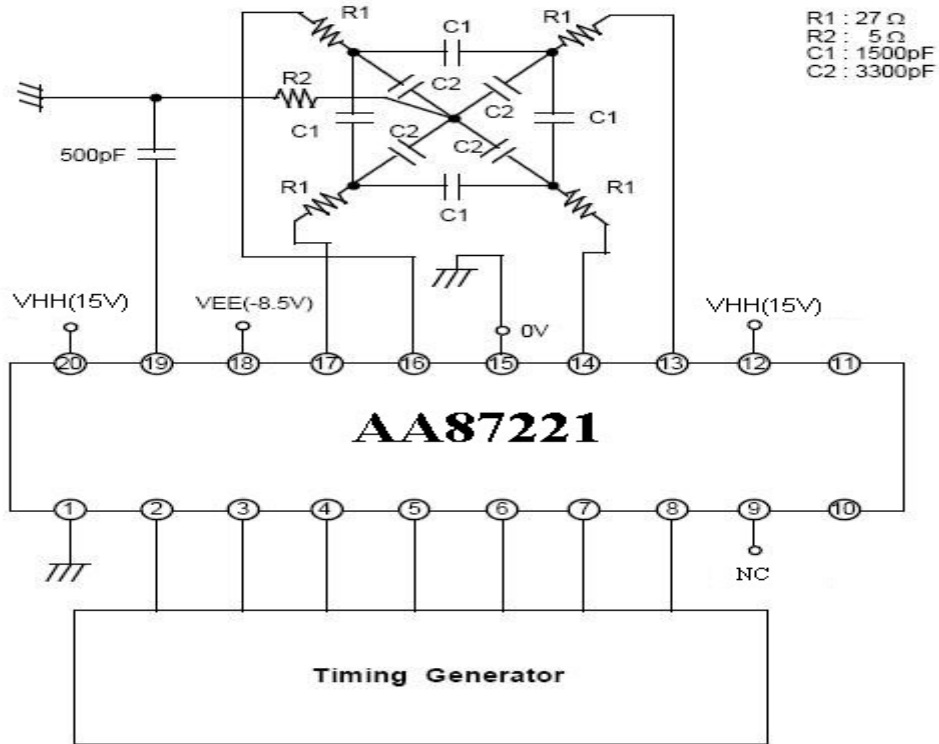

■ **OP- AMP GAIN CHARACTERISTICS**

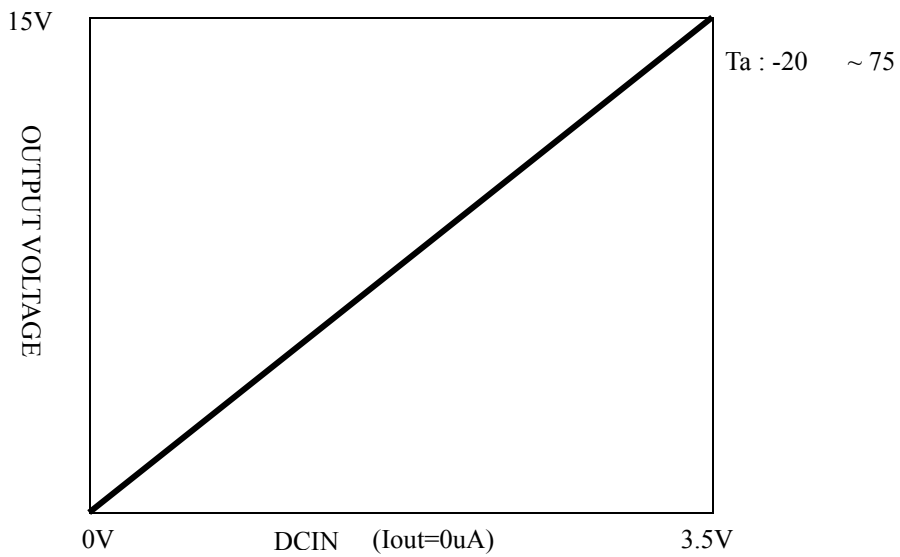



PRELIMINARY

CCD VERTICAL DRIVER

■ **AC CHARACTERISTICS** (V_{HH}=15, V_{ME}=GND, V_{EE}=-8.5V; T_a = 25)

Parameter	Symbol	Value			Unit	Condition
		Min	Typ	Max		
Delay Time	T _{PLM}	30	70	100	nS	No Load (*1)
	T _{PMH}	30	70	100	nS	
	T _{PLH}	30	70	100	nS	
	T _{PML}	30	70	100	nS	
	T _{PHM}	30	70	100	nS	
	T _{PHL}	30	70	100	nS	
Transition Time	T _{TLM}	170	250	330	nS	V _{EE} →V _{ME} (*1)
	T _{TMH}	190	240	310	nS	V _{ME} →V _{HH} (*1)
	T _{T LH}	100	150	210	nS	V _{EE} →V _{HH} (*1)
	T _{T ML}	100	200	310	nS	V _{ME} →V _{EE} (*1)
	T _{T HM}	60	110	170	nS	V _{HH} →V _{ME} (*1)
	T _{T HL}	90	140	210	nS	V _{HH} →V _{EE} (*1)
Output Noise Voltage	V _{CLH} , V _{CLL} V _{CMH} , V _{CM L}			0.5	V	(*2)

(*1) Refer Timing Diagram

(*2) Refer Noise Diagram

■ **NOISE DIAGRAM**

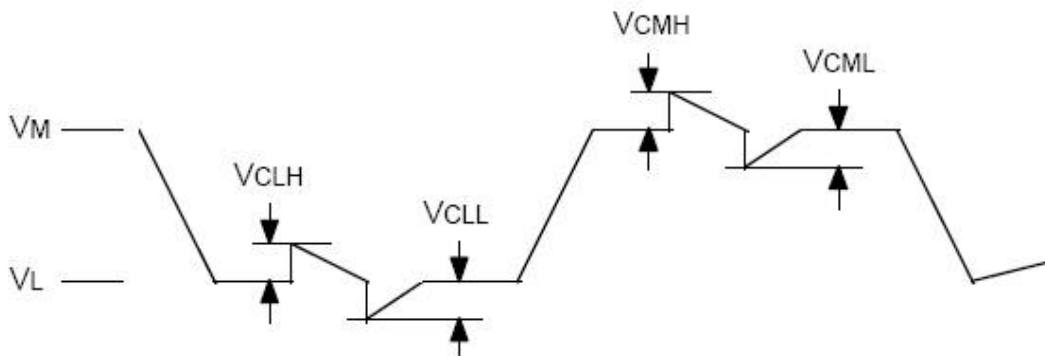

PRELIMINARY **CCD VERTICAL DRIVER**

■ **APPLICATION CIRCUIT**

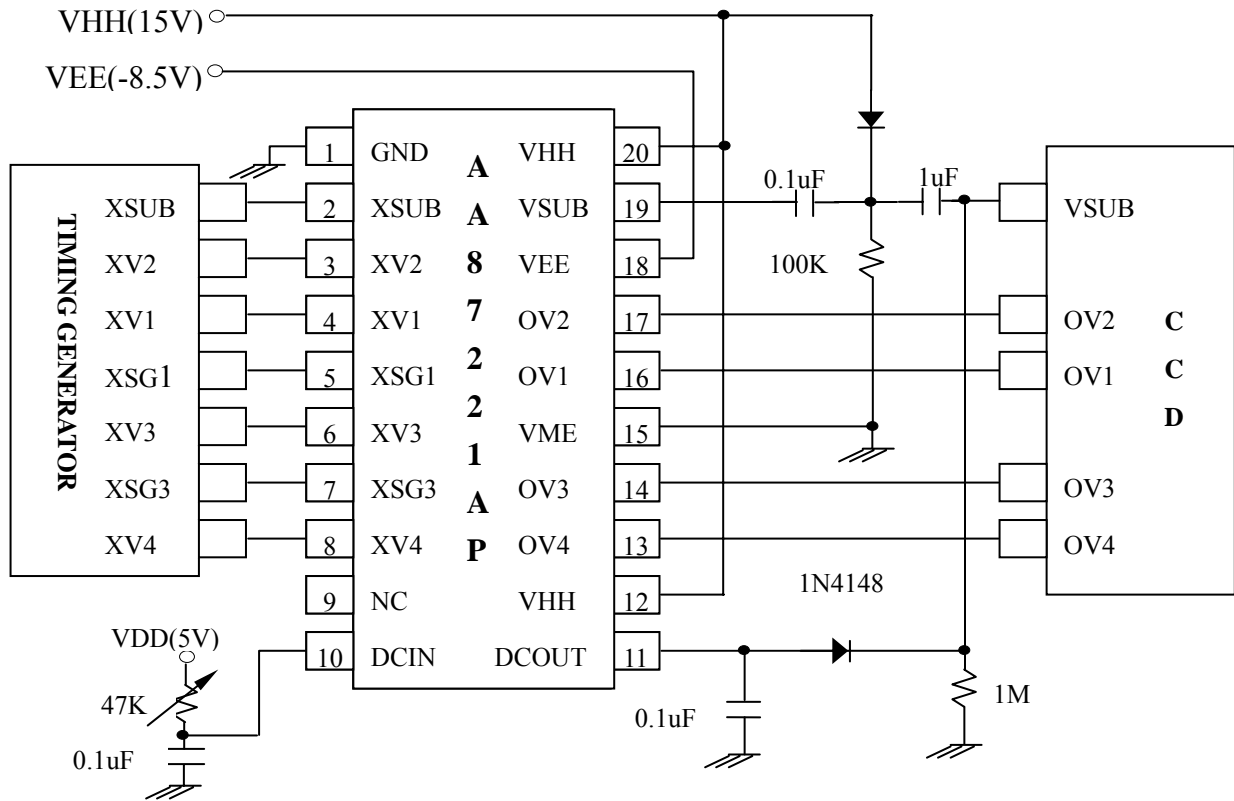

In case of $DCOUT = VHH - 1.0V$, Warning: When voltage is biased, you must keep this flow. If you don't, negative voltage is applied to CCD image sensor's SUB.

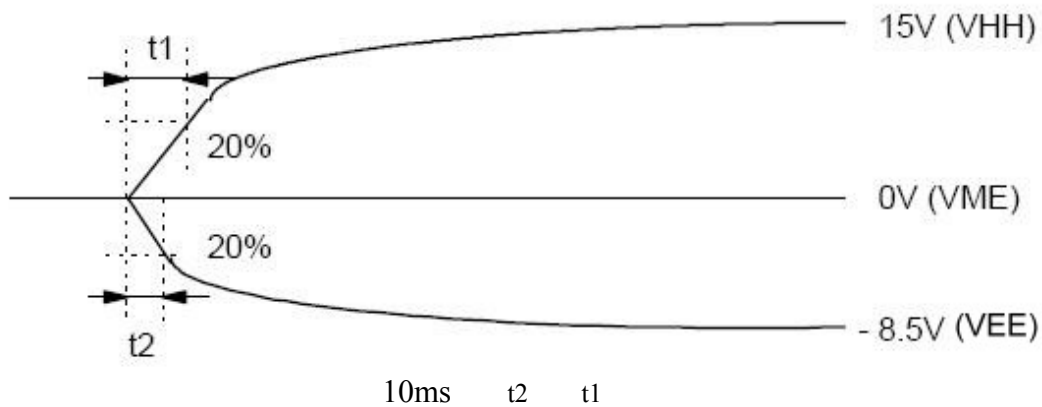

PRELIMINARY

CCD VERTICAL DRIVER

■ **TSSOP 20L PACKAGE DIMENSION**

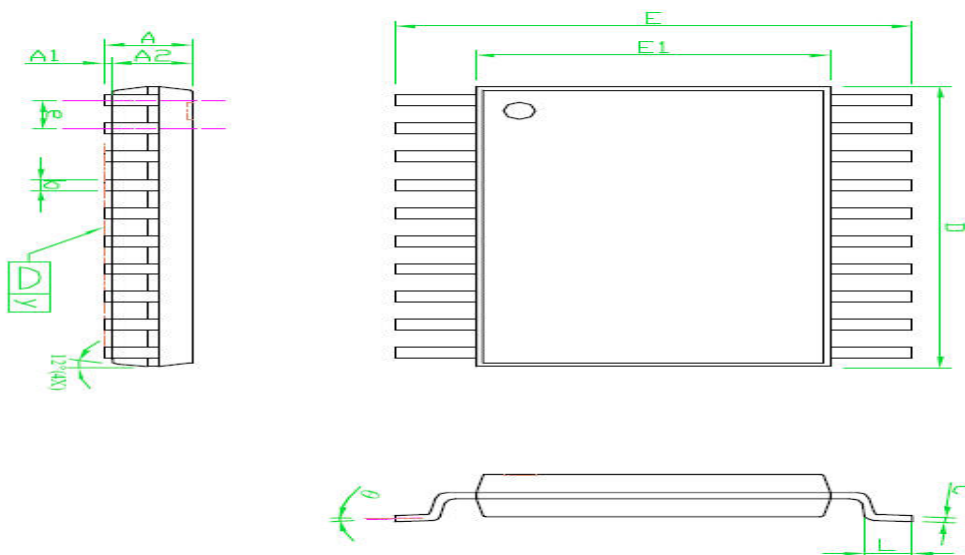

NOTE:

1. PACKAGE BODY SIZES EXCLUDE MOLD FLASH PROTRUSIONS OR GATE BURRS
2. TOLERANCE $\pm 0.1\text{mm}$ UNLESS OTHERWISE SPECIFIED
3. COPLANARITY: 0.1mm
4. CONTROLLOMG DIMENSION IS MILLIMETER. CONVERTED INCH DIMENSIONS ARE NOT NECESSARILY EXACT.
5. FOLLOWED FROM JEDEC MO-153

SYMBOLS	DIMENSIONS IN MILLIMETERS			DIMENSIONS IN INCHES		
	MIN	NOM	MAX	MIN	NOM	MAX
A	-	-	1.20	-	-	0.048
A1	0.05	-	0.15	0.002	-	0.006
A2	0.80	1.00	1.05	0.031	0.039	0.041
b	0.19	-	0.30	0.007	-	0.012
C	0.09	-	0.20	0.004	-	0.008
D	6.40	6.50	6.60	0.252	0.256	0.260
E	6.20	6.40	6.60	0.244	0.252	0.260
E1	4.30	4.40	4.50	0.169	0.173	0.177
e	-	0.65	-	-	0.026	-
L	0.45	0.60	0.75	0.018	0.024	0.030
y	-	-	0.10	-	-	0.004
θ	0°	-	8°	0°	-	8°