

1000 - 2500 Watts

VS Series

VS1-B2-H522-00
1100W total



VS3-D2-C2-20
1200W total



VS6-L2-00
1500W total



VS8-L9-D9-20
2500W total (case limit)



VS4/9
2000 - 2500 W



Special Features

- Power factor correction
- IEC 555-2 harmonic distortion compliance
- CISPR 22, EN55022 Level B conducted / radiated EMI
- EN61000 immunity standards
- European CE Mark
- Current share on all outputs
- Remote sense on all outputs
- Overload protection on all outputs
- Voltage adjustment on all outputs
- Margining on all outputs
- AC-OK-signal (logics "1" or "0")
- Global DC OK (logics "1" or "0")
- DC-OK signal and status indicator LED-on all outputs
- Global and individual module inhibits/enable
- 3 year warranty
- 2500 W with 3-phase input

Environmental

Operating temperature: -10°C to 50°C
(derate each output linearly to 60% at 70°C)
40°C max. for reverse air (option #1)

Shock/Vibration: Mil-Hdbk 810E

Humidity: 95% non-condensing

Storage temperature: -55°C to +85°C

Temperature coefficient: 0.02% per °C

Cooling: Internal DC fan 24V

Safety

UL	UL60950-1	E133211
CSA	CSA C22.2 No. 60950-1-03	
VDE	EN60950	
CB	Certificate and report	
CE	Mark	

AMERICAS

5810 Van Allen Way
 Carlsbad, CA 92008
 Telephone: 760-930-4600
 Facsimile: 760-930-0698

EUROPE

Astec House, Waterfront Business Park
 Merry Hill, Dudley
 West Midlands, DY5 1LX, UK
 Telephone: 44 (1384) 842-211
 Facsimile: 44 (1384) 843-355

ASIA

Units 2111-2116, Level 21
 Tower1, Metroplaza
 223, Hing Fong Road
 Fwai Fong, New Territories
 Hong Kong
 Telephone: 852-2437-9662
 Facsimile: 852-2402-4426



Electrical Specs

Input

Fuse rating	600 V / 25 A (internal)1Ø 250 V / 20 A (internal)3Ø
Input voltage	85-264 VAC 1Ø VS1, VS3 & VS4 (See operating curve) 180-264 VAC 3Ø VS6, VS8 & VS9
Frequency	47 to 440 Hz
Inrush current	40 A peak max.
Efficiency	75% - 82%
Power factor	0.99 typical (0.9 on VS6, VS8 & VS9)
Turn-on time	AC / 1 sec; Inhibit / 100 ms max.
EMI-filter	CISPR 22, EN55022 Level B conducted/radiated
Leakage current	2 mA max. at 240 VAC
Holdover storage	20 ms min. / 40 ms typical independent of VAC
AC-OK warning time	>5 ms (power fail)
Loss of phase	On VS6, VS8 & VS9, unit will continue to operate with loss of phase

Output

Adjustment range	±10% minimum
Margining	±4-6% nominal
Line/load reg	0.2% or 5 mV max.
Ripple	RMS: 0.1% or 10 mV P-P: 1.0% or 50 mV Bandwidth limited to 20 MHz
Dynamic response	2% or 100 mV with 25% load step (any output)
Recovery time	To within 1% in <300 µsec
Overvoltage protection	2-5 V 122% to 134% of output voltage; 12-48 V 110% to 120%; recycle AC
Overload protection	Main: 105% to 120% of rated current Auxiliaries: 105% to 140%
Short circuit protection	Protected for continuous short circuit, recovery automatic
Reverse voltage protection	100% of rated output current
Thermal protection	Each module thermally protected. Input module: auto recovery. Output modules; recycle AC.
Remote sense	Up to 0.5 V - total drop
Single wire parallel	Current share to 2% of total rated current
Switching frequency	200 KHz (900-1500 W module, 400 KHz)
DC OK	-2% to -6% of nominal
Output/Output isolation	>1 Megohm

Input Operating Curve

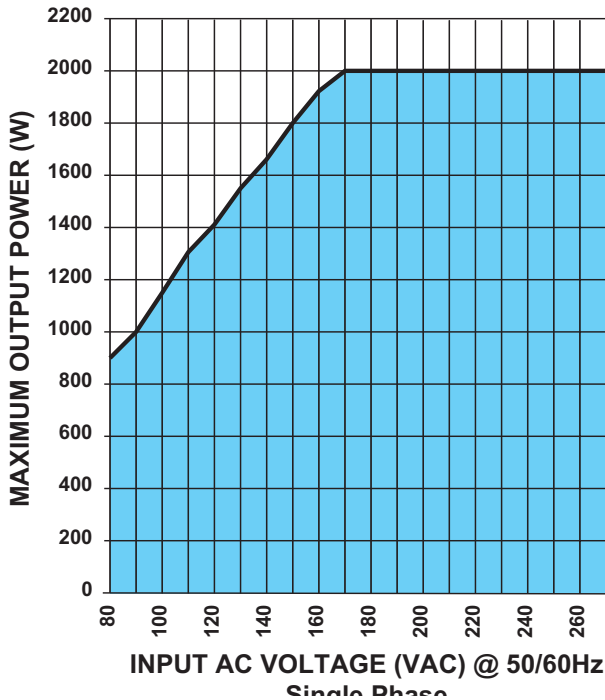

Common Examples and Specifications

Case size

- 1 = 5 inch, 2 slot, 1500 W max 1Ø
- 3 = 8 inch, 4 slot, 2000 W max 1Ø
- 4 = 11 inch, 6 slot, 2000 W max 1Ø
- 6 = 5 inch, 2 slot, 1500 W max 3Ø
- 8 = 8 inch, 4 slot, 2500 W max 3Ø
- 9 = 11 inch, 6 slot, 2500 W max 3Ø

(Same for Each Slot)

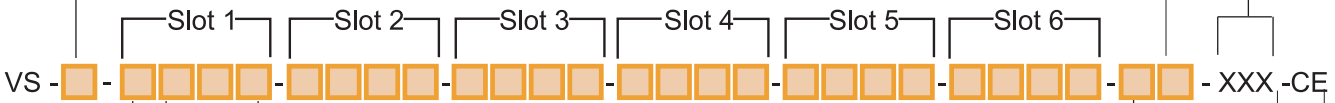

Option Codes

- 0 = no options
- 1 = rear air exhaust (40°C max.)
- 3 = set unit for global enable
- 5 = options 1 & 3

USE ONLY FOR MODIFIED STANDARD, CONSULT-FACTORY

Indicates CE compliance

Output Module Code

- A = 300 W single 1 slot
- B = 600 W single 1 slot
- C = 900 W single 2 slots
- D = 1200 W single 2 slots
- E = 250 W dual 1 slot
- F = 250 W triple 1 slot
- G = 500 W dual 1 slot
- H = 500 W triple 1 slot
- K = 750 W single 1 slot
- L = 1500 W single 2 slots

Output Voltage Code

- 0 = 2V
- 1 = 3.3V
- 2 = 5V
- 3 = 12V
- 4 = 15V
- 5 = 24V
- 6 = 28V
- 7 = 36V
- 8 = special voltage (consult factory)
- 9 = 48V

Configuration Rules

1. Omit digits that do not apply.
2. a. Specify modules from lowest number of outputs to highest.
b. If number of outputs are equal, specify from highest to lowest power increments.
c. If power increments are equal, specify from highest to lowest current.
3. All model configurations created using this selection guide represent standard products with standard availability and lead times.
4. If slots are left empty, a blank panel will be automatically installed.

Parallel Code

VS1 and VS6 available slots

VS3 and VS8 available slots

VS4 and VS9 available slots

Parallel Codes

- 0 = no parallel
- 1 = 1 & 2
- 2 = 2 & 3
- 3 = 3 & 4
- 4 = 1 & 2 & 3
- 5 = 2 & 3 & 4
- 6 = 1 & 2 + 3 & 4
- 7 = 1 & 2 & 3 & 4
- 8 = 3 & 4 + 5 & 6
- 9 = 1 & 2 + 3 & 4 + 5 & 6

Example

(more on next page):

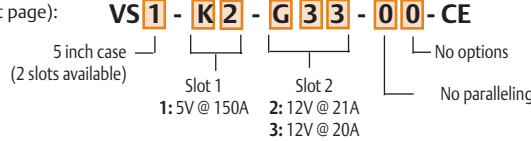

Output Current

Output Voltage Identification		Module Identification							
Output Voltage Code	Output Voltage	A (1 slot) 300 W Single	B (1 slot) 600 W Single	C (2 slots) 900 W Single	D (2 slots) 1200 W Single	E, F (1 slot) 250 W Multi Main Output	G, H (1 slot) 500 W Multi Main Output	K (1 slot) 750 W Single	L (2 slots) 1500 W Single
0	2 V	60 A	120 A	180 A	240 A	25 A	50 A	150 A	300 A
1	3.3 V	60 A	120 A	180 A	240 A	25 A	50 A	150 A	300 A
2	5 V	60 A	120 A	180 A	240 A	25 A	50 A	150 A	300 A
3	12 V	25 A	50 A	75 A	100 A	10.5 A	21 A	62.5 A	125 A
4	15 V	20 A	40 A	60 A	80 A	8.3 A	16.6 A	50 A	100 A
5	24 V	12.5 A	25 A	37.5 A	50 A	5.3 A	10.5 A	31.2 A	62.4 A
6	28 V	10.7 A	21.4 A	32.1 A	42.8 A	4.5 A	9 A	26.7 A	53.4 A
7	36 V	8.3 A	16.6 A	24.9 A	33.2 A	N/A	N/A	20.8 A	41.6 A
9	48 V	6.3 A	12.5 A	18.75 A	25 A	N/A	N/A	15.6 A	31.2 A

Note: Increments of current not shown can be achieved by paralleling modules (add currents of each module selected).

Auxiliary Output Table: Output(s) 2 and/or 3 of Module

Voltage Identification		Module Identification			
Output Voltage Code	Output Voltage	E 250 W Dual Aux. Output	F 250 W Triple Aux. Output	G 500 W Dual Aux. Output	H 500 W Triple Aux. Output
0	2 V	10 A	5 A	20 A	10 A
1	3.3 V	10 A	5 A	20 A	10 A
2	5 V	10 A	5 A	20 A	10 A
3	12 V	10 A	5 A	20 A	10 A
4	15 V	10 A	5 A	20 A	10 A
5	24 V	5 A	2.5 A	10 A	5 A
6	28 V	5 A	2.5 A	10 A	5 A

AMERICAS

5810 Van Allen Way
Carlsbad, CA 92008
Telephone: 760-930-4600
Facsimile: 760-930-0698

EUROPE

Astec House, Waterfront Business Park
Merry Hill, Dudley
West Midlands, DY5 1LX, UK
Telephone: 44 (1384) 842-211
Facsimile: 44 (1384) 843-355

ASIA

Units 2111-2116, Level 21
Tower1, Metroplaza
223, Hing Fong Road
Fwai Fong, New Territories
Hong Kong
Telephone: 852-2437-9662
Facsimile: 852-2402-4426



EXAMPLES

Examples of Model Numbers - SINGLE OUTPUTS

Total Power	Volts / Amps	Size (H x W x L)	Model Number	Other Voltages Available	Voltage ID Code
600 W	5 V / 120 A	5 x 5 x 11	VS1-B2-00	2 V	0
750 W	12 V / 62.5 A	5 x 5 x 11	VS1-K3-00	3.3 V	1
900 W	5 V / 180 A	5 x 5 x 11	VS1-C2-00	5 V	2
1200 W	5 V / 240 A	5 x 5 x 11	VS1-D2-00	12 V	3
1200 W	2 V / 600 A	5 x 8 x 11	VS3-L0-L0-20	15 V	4
1500 W	15 V / 100 A	5 x 5 x 11	VS1-L4-00	24 V	5
2000 W	5 V / 400 A	5 x 8 x 11	VS3-D2-C2-20*	28 V	6
2500 W	48 V / 52 A	5 x 8 x 11	VS8-L9-D9-20**	36 V	7
				Special 48 V	8 (consult factory)
					9

* D2 module derated to 1100 W (2000 W max.)
**D9 module derated to 1000 W (2500 W max.)

Examples of Model Numbers - MULTIPLE OUTPUTS

Total Power	Output 1	Output 2	Output 3	Output 4	Output 5	Output 6	Size	Model Number
500 W	5 / 50	12 / 10	12 / 10				5 x 5 x 11	VS1-H233-00
750 W	5 / 50	12 / 10	12 / 10	15 / 8.3	15 / 5	5 / 5	5 x 5 x 11	VS1-H233-F442-00
800 W	5 / 60	12 / 21	12 / 10	5 / 10			5 x 5 x 11	VS1-A2-H332-00
800 W	5 / 60	12 / 21	12 / 10	24 / 5			5 x 5 x 11	VS1-A2-H335-00
800 W	5 / 60	15 / 16.6	15 / 10	5 / 10			5 x 5 x 11	VS1-A2-H442-00
800 W	5 / 60	15 / 16.6	15 / 10	24 / 5			5 x 5 x 11	VS1-A2-H445-00
990 W	5 / 150	2 / 120					5 x 5 x 11	VS1-K2-B0-00
1000 W	5 / 50	12 / 10	12 / 10	15 / 16.6	15 / 10	24 / 5	5 x 5 x 11	VS1-H233-H445-00
1000 W	5 / 50	12 / 10	12 / 10	15 / 16.6	5 / 10	24 / 5	5 x 5 x 11	VS1-H233-H425-00
1100 W	5 / 120	12 / 21	12 / 20				5 x 5 x 11	VS1-B2-G33-00
1100 W	5 / 120	12 / 21	12 / 10	5 / 10			5 x 5 x 11	VS1-B2-H332-00
1100 W	5 / 170	12 / 10	12 / 10				5 x 5 x 11	VS1-B2-H233-10
1100 W	5 / 120	15 / 16.6	15 / 10	5 / 10			5 x 5 x 11	VS1-B2-H442-00
1100 W	5 / 120	15 / 16.6	15 / 10	24 / 5			5 x 5 x 11	VS1-B2-H445-00
1400 W	5 / 180	12 / 21	12 / 20				5 x 8 x 11	VS3-C2-G33-00
1400 W	5 / 180	12 / 21	12 / 10	5 / 10			5 x 8 x 11	VS3-C2-H332-00
1440 W	5 / 240	2 / 120					5 x 8 x 11	VS3-D2-B0-00
1600 W	5 / 170	12 / 20	12 / 21	5 / 20			5 x 8 x 11	VS3-B2-G23-G32-10
1680 W	5 / 240	2 / 240					5 x 8 x 11	VS3-D2-D0-00
1700 W	5 / 240	12 / 21	12 / 20				5 x 8 x 11	VS3-D2-G33-00
1900 W	5 / 180	12 / 21	12 / 20	5 / 50	15 / 10	24 / 5	5 x 8 x 11	VS3-C2-G33-H245-00
2000 W	5 / 300	12 / 21	12 / 10	5 / 10			5 x 8 x 11	VS3-L2-H332-00
2000 W	5 / 240	12 / 21	12 / 20	5 / 60	15 / 10	24 / 5	5 x 8 x 11	VS3-D2-G33-H245-00
2500 W	5 / 300	3.3 / 120	12 / 21	12 / 10	15 / 10		5 x 8 x 11	VS8-L2-B1-H334-00

Pin Assignments

PFC

J1 CONTROL CONNECTOR

Pin No.	Function
J1-1	AC OK Logic 1
J1-2	AC OK Logic 0
J1-3	Global DC OK/Conv Run Logic 1
J1-4	Global DC OK/Conv Run Logic 0
J1-5	Global DC OK/Conv Run/AC OK Return
J1-6	Global Inhibit Logic 0*/ENA Logic '0'
J1-7	Global Inhibit Logic 1*/ENA Logic '1'
J1-8	Global Inhibit Return*ENA RTN
J1-9	Global Isolated Inhibit
J1-10	Global Isolated Inhibit Return

* Changes to Enable with Option Code 3

Multiple Output

J1 CONTROL CONNECTOR

Pin No.	Function
J1-1	V1 +Remote Sense
J1-2	V1 Remote Margin / V. Program
J1-3	V1 Remote Margin Hi
J1-4	V1 -Remote Sense / Margin Lo
J1-5	V1 DC OK / Conv Run Logic 1
J1-6*	V1 Isolated Inhibit
J1-7	V1 DC OK / Conv Run / ISO Inh. Return
J1-8	V1 Single Wire Parallel
J1-9	V2 Single Wire Parallel
J1-10	V3 Single Wire Parallel

* Inhibits off all the outputs within that module.

Single Output

J1 CONTROL CONNECTOR

Pin No.	Function
J1-1	+Remote Sense
J1-2	Remote Margin / V. Program
J1-3	Remote Margin Hi
J1-4	-Remote Sense / Margin Lo
J1-5	DC OK / Conv Run Logic 1
J1-6	Isolated Inhibit
J1-7	DC OK / Conv Run / ISO Inh. Return
J1-8	Single Wire Parallel
J1-9	Spare Pin
J1-10	Spare Pin

J2 CONTROL CONNECTOR

Pin No.	Function
J2-1	V2 +Remote Sense
J2-2	V2 Remote Margin / V. Program
J2-3	V2 Remote Margin Hi
J2-4	V2 -Remote Sense / Margin Lo
J2-5	V2 DC OK / Logic 1
J2-6	V3 +Remote Sense
J2-7	V3 Remote Margin / V. Program
J2-8	V3 Remote Margin Hi
J2-9	V3 -Remote Sense
J2-10	V3 DC Good / Logic 1

Notes:

Electrical Characteristics

- DC OK minus 2 to 6% of nominal output voltage (tracking).
- Inhibit & Enable are both TTL compatible. ISOLATED requires 2 mA source, typical.
- DC OK/Converter Run denotes output voltage is present and converters are running (Or'ed signal configuration).
- PFC LED: Red = Bulk DC bus voltage low; Green = Bulk DC OK.
- Output LED: Red = Indicated output not operating within tolerance; Green = Indicated output operating within tolerance.
- The 5 x 5 x 11 (VS1/6) case is power limited to 1500W max. See operating curve.
- The 5 x 8 x 11 case and 5 x 11 x 11 case (VS3/4) are power limited to 2000W max. The VS8/9 cases are power limited to 2500W max.
- Specifications subject to change without notice.
- Warranty: 3 yrs

Drawings

VS1 & VS6 • 1000-1500 WATTS

5-inch Case Size (5" x 5" x 11")

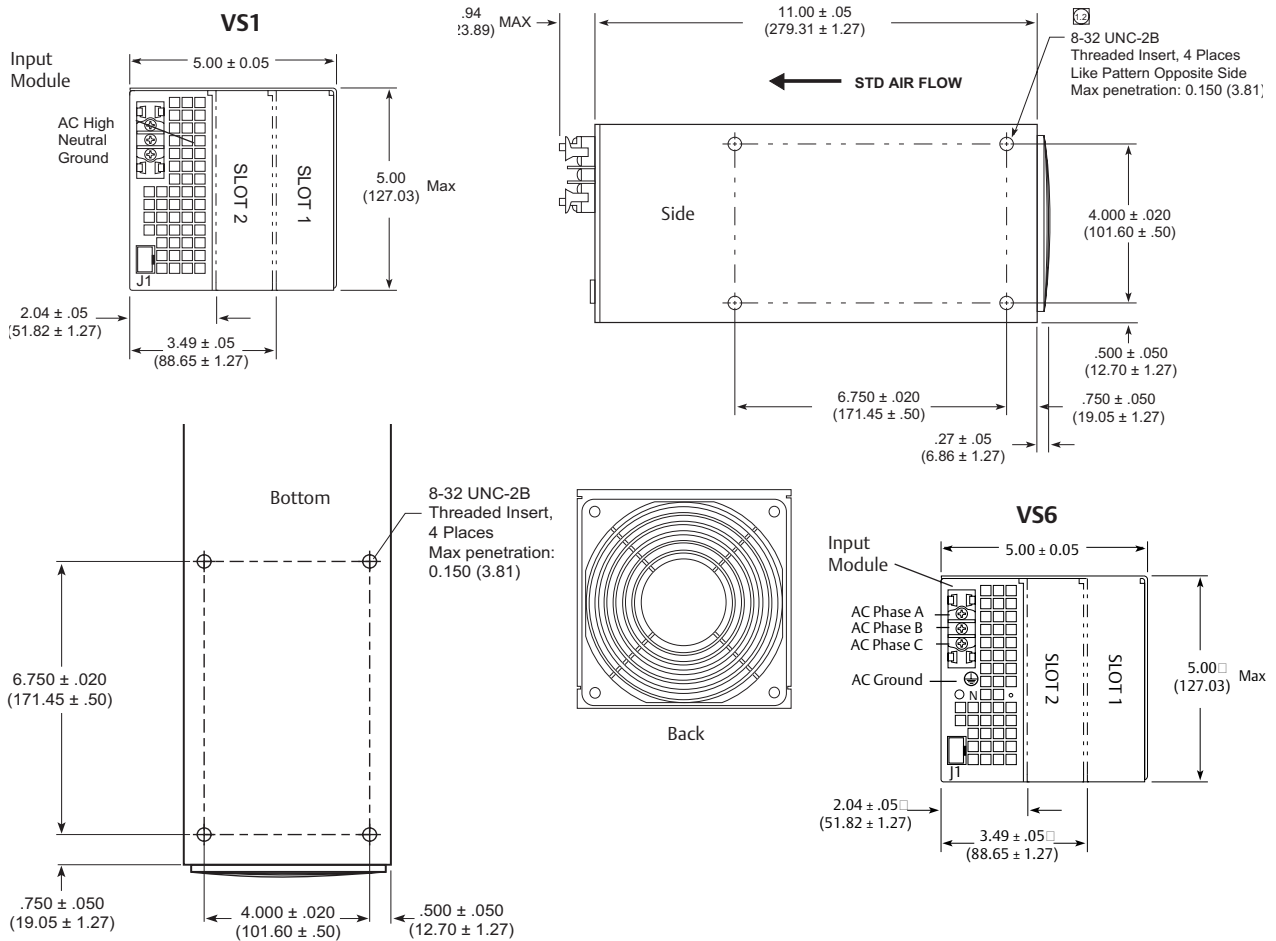

NOTES (ALL MODELS)

- Input: Barrier type. Three No. 6-32 B.H. screws (0.375" centers). For VS1, VS3 & VS4 additional GND CONN added for VS6, VS8 & VS9. Max torque: 10 in-lbs (1.1 N-m).
- Control connectors: (J1 and J2) 10 position Molex 90130-3210 housing, gold plated contacts. Mates with Molex 90142-0010 housing with 90119-2110 crimp contacts (Molex C - Grid III Series). Connector kit includes mating connector and 10 pins, Astec part #70-841-004.
- Output terminals (A-300 W) (B-600 W) & (K-750 W) single modules: two (2) 10-32 UNF HEX HD BOLTS. Max. torque: 25 in-lbs (2.78 N-m).
- Output terminals (E/F-250 W) & (G/H-500 W) dual/triple modules: Primary: two (2) 10-32 UNF HEX HD BOLTS. Max. torque: 25 in-lbs (2.78 N-m). Secondary: barrier strip two (2) 6-32 UNC screws (0.375" centers) per output. Max torque: 10 in-lbs (1.1 N-m).
- Output terminals (C-900 W) (D-1200 W) & (L-1500 W) single modules: four 5/16-18 x 5/8" hex head cap screws. Max. torque: 120 in-lbs (13.35 N-m). Captive lock washer provided.
- Chassis material: aluminum with chemical film coating.
- Adjustment access: voltage, power fail, and overcurrent from front panel.
- Bar code: code 39 extended.
- Mounting for 5-inch & 8-inch case: four (4) 8-32 clinch nuts on three (3) surfaces.
Mounting for 11-inch case: four (4) 8-32 clinch nuts on two (2) side surfaces & six (6) 8-32 clinch nuts on bottom surface.
Max. penetration 0.150 inch (3.81). Max. torque: 15 in-lbs (1.67 N-m).
- Additional support is recommended when unit is mounted in a suspended configuration.
Mounting clinch nuts are not designed to support the weight of the unit.
- Fans: 5-inch case, (1) 4.5" dia, 112 CFM (no load), 49 dBA.
8-inch case, (1) 4.5" dia, 112 CFM (no load), 49 dBA; (2) 2.25" dia, 23 CFM (no load), 38 dBA.
11-inch case, (2) 4.5" dia, 112 CFM (no load), 49dBA
- All dimensions are in inches (mm).
- Specifications subject to change without notice.

AMERICAS

5810 Van Allen Way
 Carlsbad, CA 92008
 Telephone: 760-930-4600
 Facsimile: 760-930-0698

EUROPE

Astec House, Waterfront Business Park
 Merry Hill, Dudley
 West Midlands, DY5 1LX, UK
 Telephone: 44 (1384) 842-211
 Facsimile: 44 (1384) 843-355

ASIA

Units 2111-2116, Level 21
 Tower1, Metroplaza
 223, Hing Fong Road
 Fwai Fong, New Territories
 Hong Kong
 Telephone: 852-2437-9662
 Facsimile: 852-2402-4426



VS Series

8-inch Case Size (5" x 8" x 11")
 (18 lbs. / 8.2 kg. maximum)

DRAWINGS • VS3 & VS8 • 1000-2500 WATTS

VS3

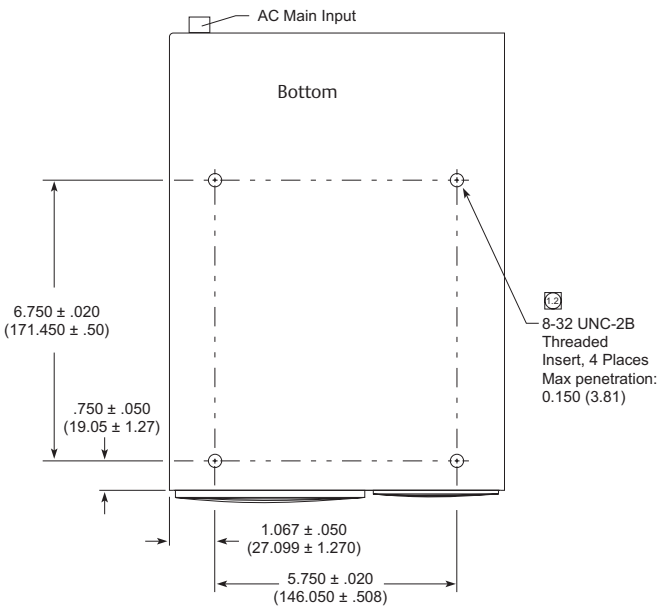
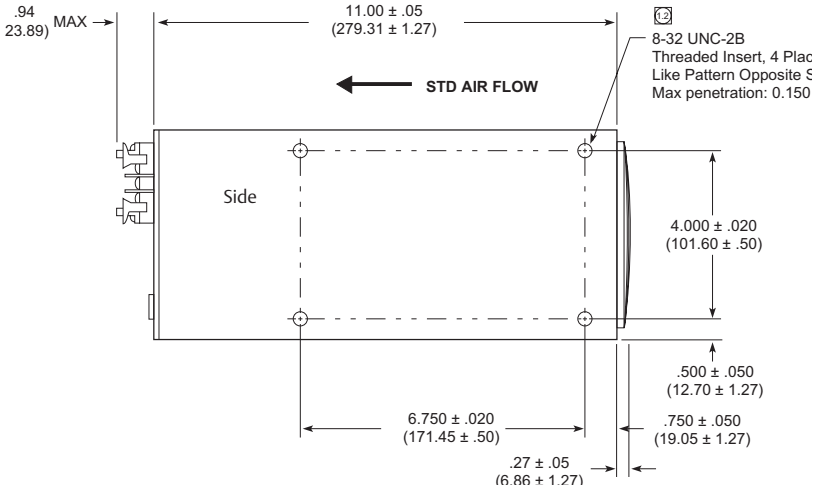
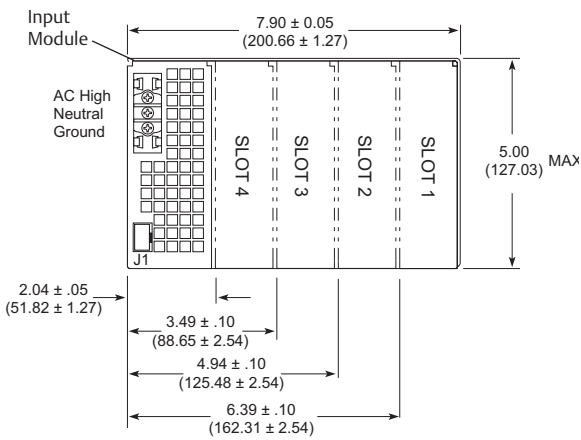

Back

VS8

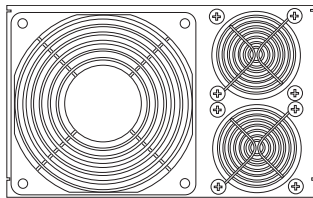
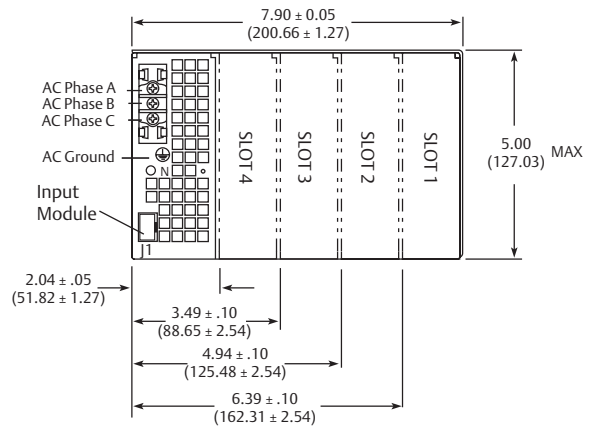

Drawings

VS4 & VS9 • 2000-2500 WATTS

11-inch Case Size (5" x 11" x 11")

VS4

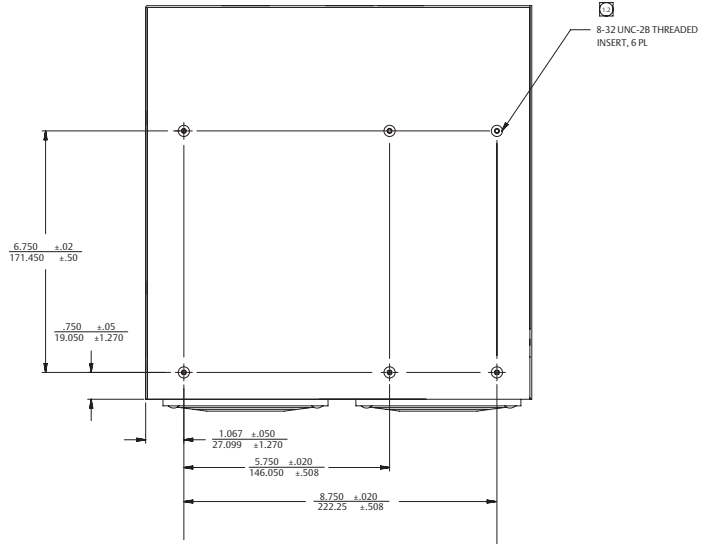
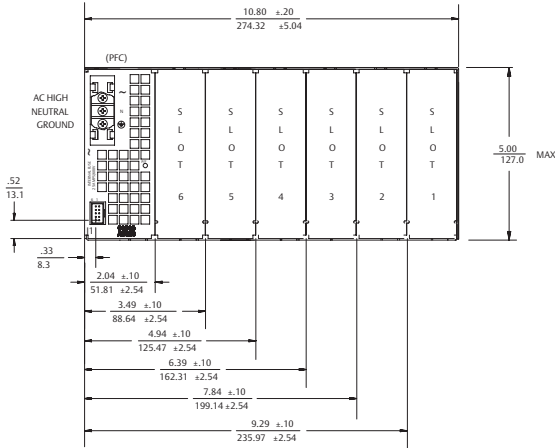

VS9

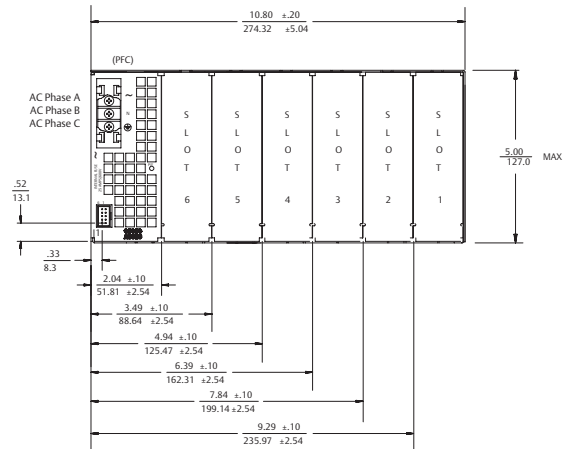
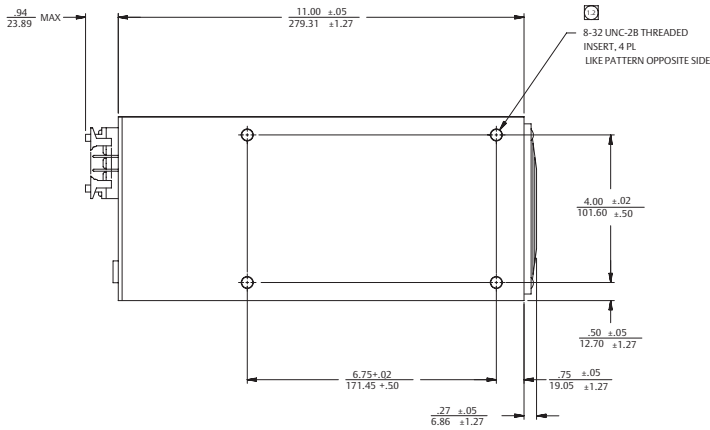

AMERICAS

5810 Van Allen Way
 Carlsbad, CA 92008
 Telephone: 760-930-4600
 Facsimile: 760-930-0698

EUROPE

Astec House, Waterfront Business Park
 Merry Hill, Dudley
 West Midlands, DY5 1LX, UK
 Telephone: 44 (1384) 842-211
 Facsimile: 44 (1384) 843-355

ASIA

Units 2111-2116, Level 21
 Tower1, Metroplaza
 223, Hing Fong Road
 Fwai Fong, New Territories
 Hong Kong
 Telephone: 852-2437-9662
 Facsimile: 852-2402-4426



Module Front Panels

