

Silicon NPN Power Transistors

2SC5129

DESCRIPTION

- With TO-3P(H)IS package
- High speed
- High voltage
- Low saturation voltage

APPLICATIONS

- Horizontal deflection output for high resolution display,colorTV
- High speed switching applications

PINNING

PIN	DESCRIPTION
1	Base
2	Collector
3	Emitter

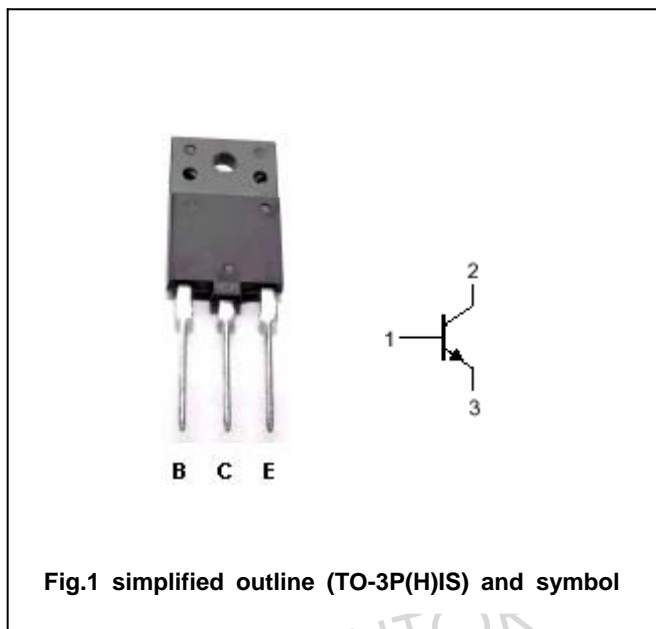

Absolute maximum ratings(Ta=25 )

SYMBOL	PARAMETER	CONDITIONS	VALUE	UNIT
V <sub>CBO</sub>	Collector-base voltage	Open emitter	1500	V
V <sub>CEO</sub>	Collector-emitter voltage	Open base	600	V
V <sub>EBO</sub>	Emitter-base voltage	Open collector	5	V
I <sub>C</sub>	Collector current		10	A
I <sub>CM</sub>	Collector current-Peak		20	A
I <sub>B</sub>	Base current		5	A
P <sub>T</sub>	Total power dissipation	T <sub>C</sub> =25	50	W
T <sub>j</sub>	Junction temperature		150	
T <sub>stg</sub>	Storage temperature		-55~150	

## Silicon NPN Power Transistors

2SC5129

## CHARACTERISTICS

T<sub>j</sub>=25 unless otherwise specified

SYMBOL	PARAMETER	CONDITIONS	MIN	TYP.	MAX	UNIT
V <sub>(BR)CEO</sub>	Collector-emitter breakdown voltage	I <sub>C</sub> =10mA ; I <sub>B</sub> =0	600			V
V <sub>CEsat</sub>	Collector-emitter saturation voltage	I <sub>C</sub> =6A; I <sub>B</sub> =1.5A			3.0	V
V <sub>BEsat</sub>	Base-emitter saturation voltage	I <sub>C</sub> =6A ; I <sub>B</sub> =1.5A			1.4	V
I <sub>CBO</sub>	Collector cut-off current	V <sub>CB</sub> =1500V; I <sub>E</sub> =0			1	mA
I <sub>EBO</sub>	Emitter cut-off current	V <sub>EB</sub> =5V; I <sub>C</sub> =0			10	μA
h <sub>FE-1</sub>	DC current gain	I <sub>C</sub> =1A ; V <sub>CE</sub> =5V	10		30	
h <sub>FE-2</sub>	DC current gain	I <sub>C</sub> =6A ; V <sub>CE</sub> =5V	4		8	
C <sub>ob</sub>	Collector output capacitance	I <sub>E</sub> =0 ; V <sub>CB</sub> =10V, f=1MHz		135		pF
f <sub>T</sub>	Transition frequency	I <sub>C</sub> =0.1A ; V <sub>CE</sub> =10V		1.7		MHz
Switching times (inductive load)						
t <sub>s</sub>	Storage time	I <sub>CP</sub> =5A; I <sub>B1(end)</sub> =1A f <sub>H</sub> =64kHz			4.0	μs
t <sub>f</sub>	Fall time				0.3	μs

Silicon NPN Power Transistors

2SC5129

PACKAGE OUTLINE

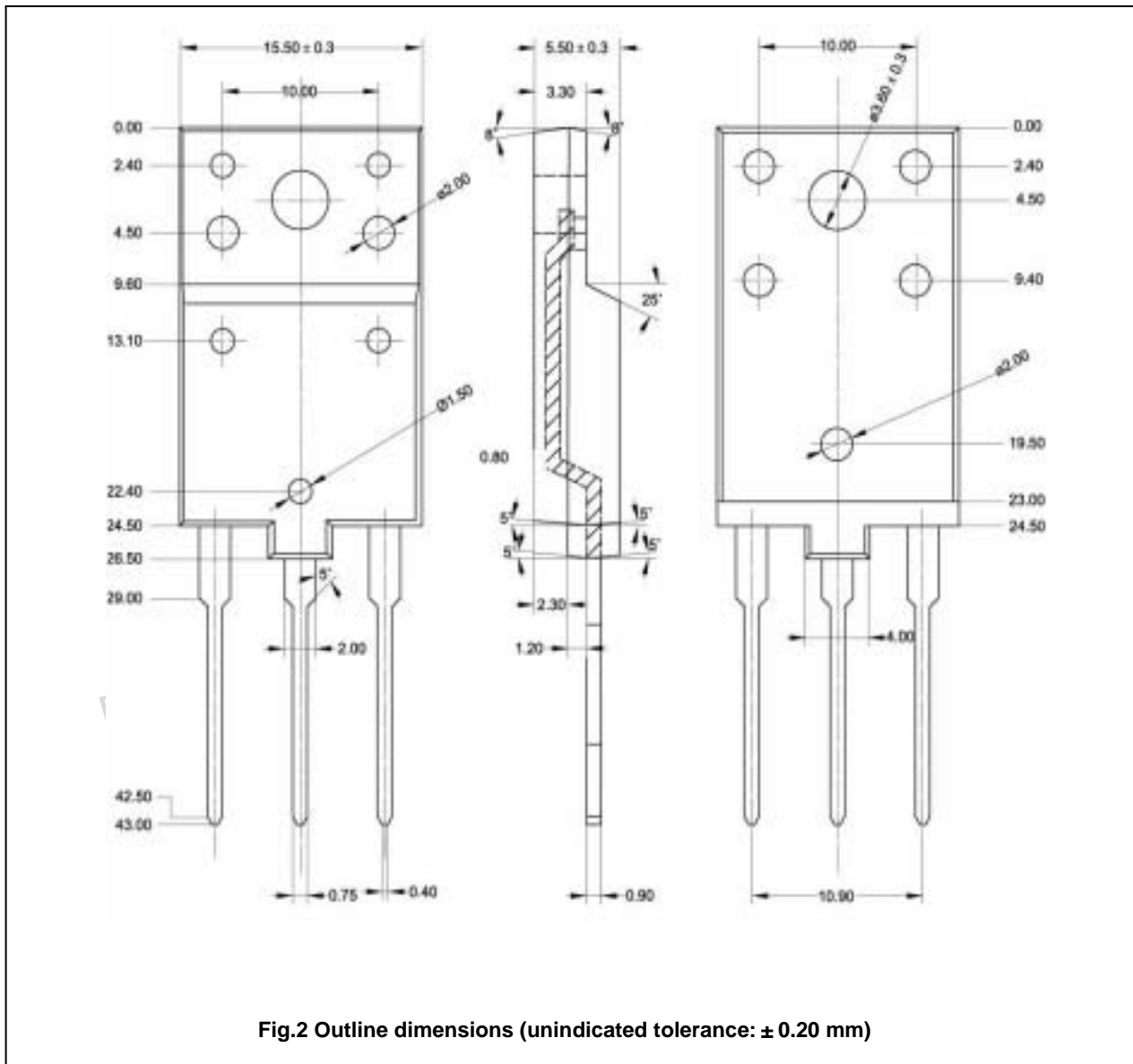

Silicon NPN Power Transistors

2SC5129

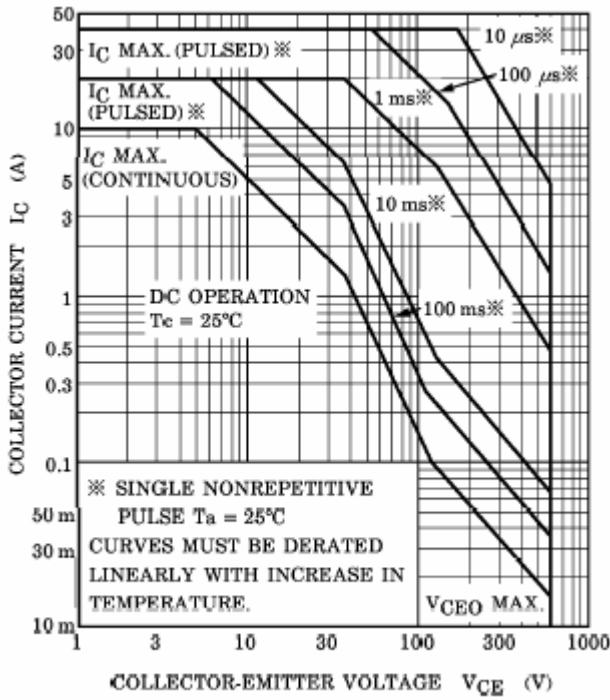
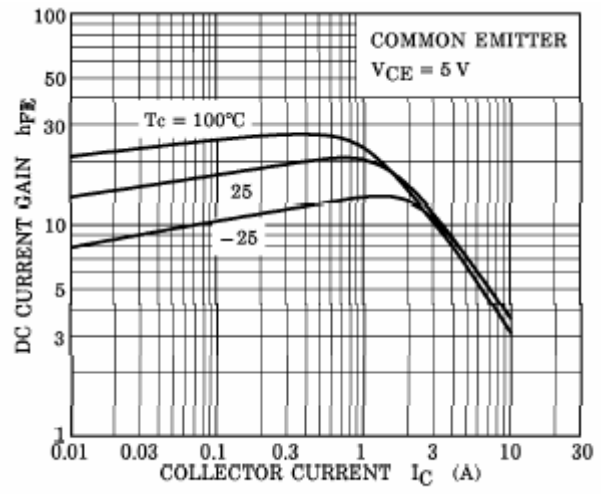
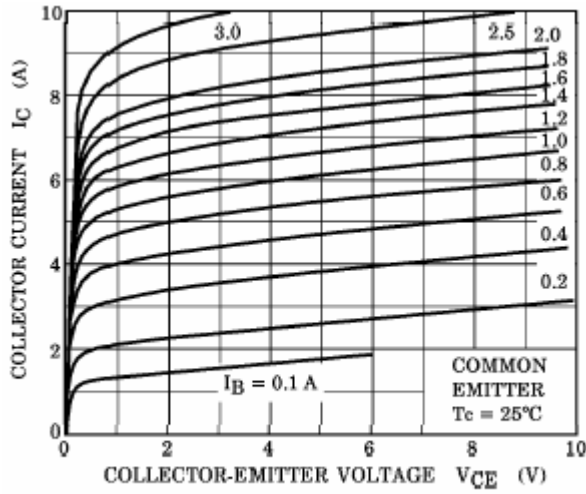

EMICONDUTOR