

Silicon NPN Power Transistors

2SC5280

DESCRIPTION

- With TO-3P(H)IS package
- High voltage
- Low saturation voltage
- High speed
- Built-in damper diode

APPLICATIONS

- High speed switching applications
- Horizontal deflection output for medium resolution display,color TV

PINNING

PIN	DESCRIPTION
1	Base
2	Collector
3	Emitter

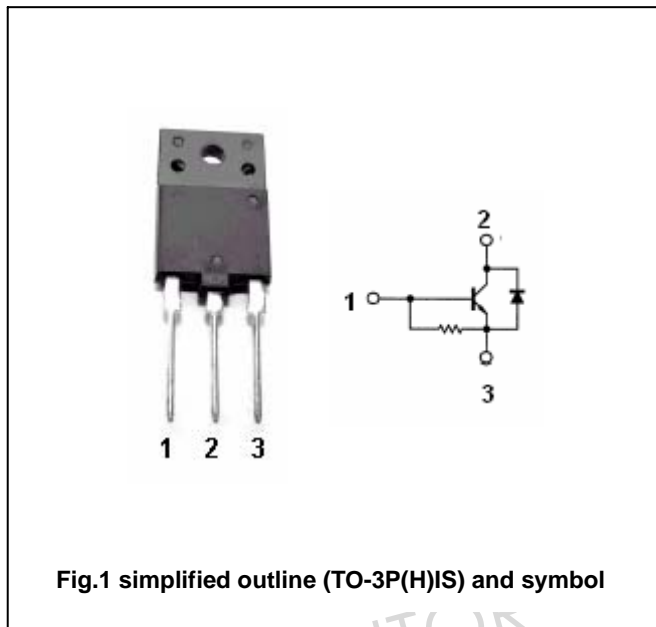

Fig.1 simplified outline (TO-3P(H)IS) and symbol

Maximum absolute ratings(Tc=25)

SYMBOL	PARAMETER	CONDITIONS	VALUE	UNIT
V _{CB0}	Collector-base voltage	Open emitter	1500	V
V _{CEO}	Collector-emitter voltage	Open base	600	V
V _{EBO}	Emitter-base voltage	Open collector	5	V
I _C	Collector current		8	A
I _{CM}	Collector current-peak		16	A
I _B	Base current		4	A
P _C	Collector power dissipation	T _C =25	50	W
T _j	Junction temperature		150	
T _{stg}	Storage temperature		-55~150	

Silicon NPN Power Transistors

2SC5280

CHARACTERISTICS

T_j=25 unless otherwise specified

SYMBOL	PARAMETER	CONDITIONS	MIN	TYP.	MAX	UNIT
V _{CEsat}	Collector-emitter saturation voltage	I _C =6A; I _B =1.5 A			5	V
V _{BEsat}	Base-emitter saturation voltage	I _C =6A; I _B =1.5 A		1.0	1.5	V
V _{(BR)EBO}	Emitter-base breakdown voltage	I _E =400mA; I _C =0	5			V
I _{EBO}	Emitter cut-off current	V _{EB} =5V; I _C =0	72		250	mA
I _{CBO}	Collector cut-off current	V _{CB} =1500V; I _E =0			1	mA
h _{FE-1}	DC current gain	I _C =1 A ; V _{CE} =5V	10		35	
h _{FE-2}	DC current gain	I _C =6A ; V _{CE} =5V	4		8.5	
f _T	Transition frequency	I _E =0.1A ; V _{CE} =10V		2		MHz
C _{OB}	Collector output capacitance	I _E =0 ; V _{CB} =10V; f=1MHz		115		pF
V _F	Diode forward voltage	I _F =6A		1.4	1.8	V
Switching times						
t _{stg}	Storage time	I _{CP} =6A; I _{B1(end)} =1.2A f _H =31.5kHz		4	6	μs
t _f	Fall time			0.2	0.5	μs

Silicon NPN Power Transistors

2SC5280

PACKAGE OUTLINE

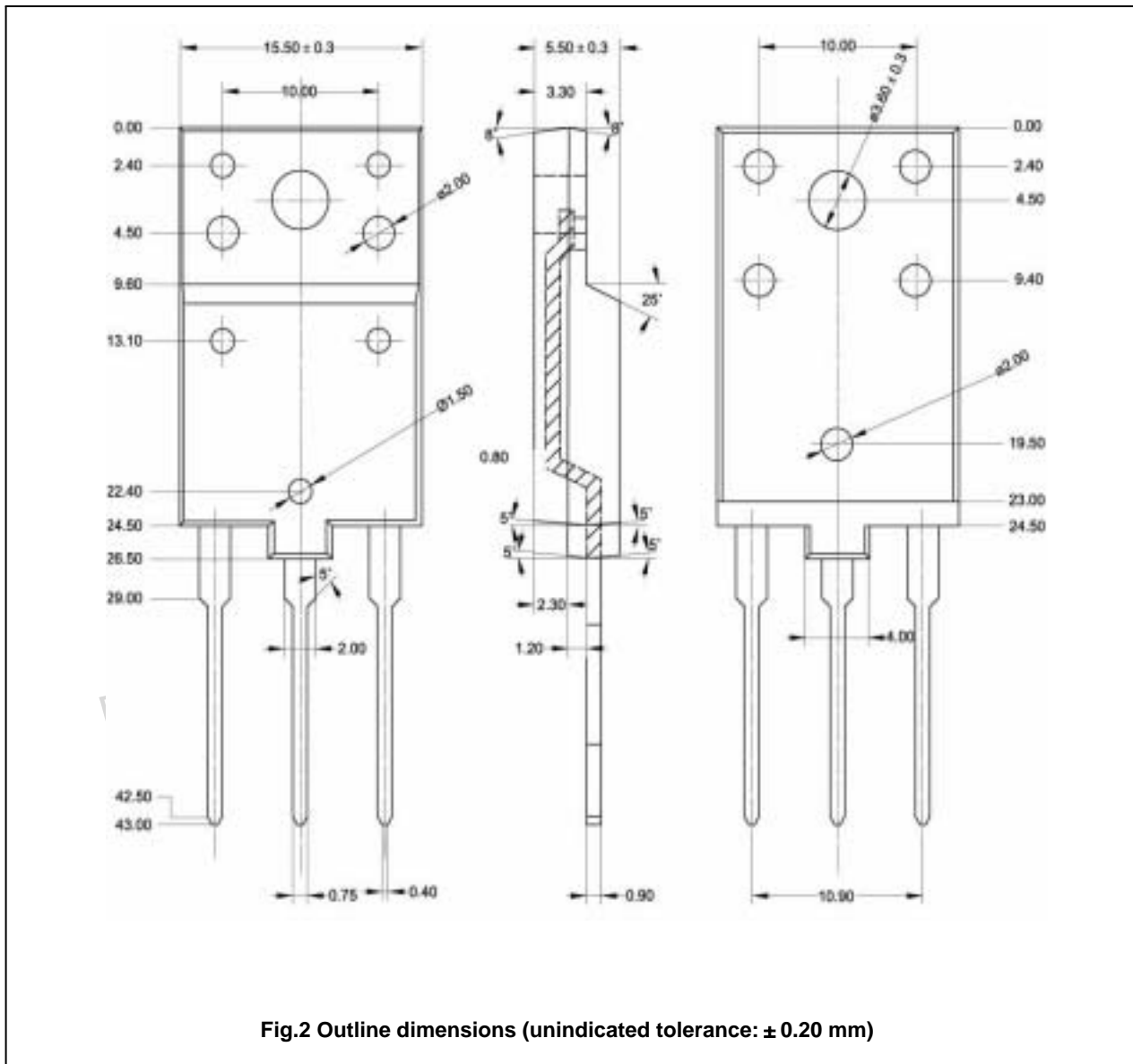

Silicon NPN Power Transistors

2SC5280

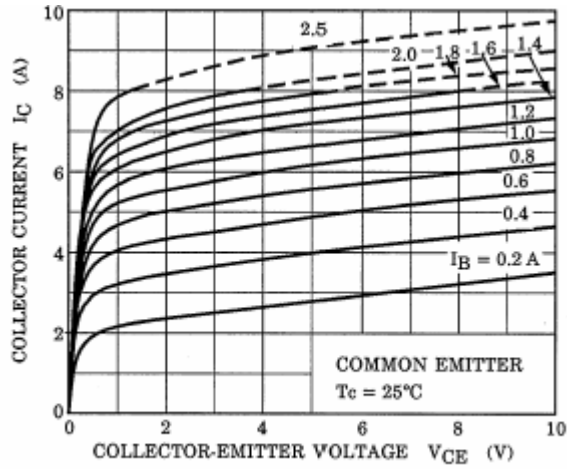

Fig.3 Static Characteristic

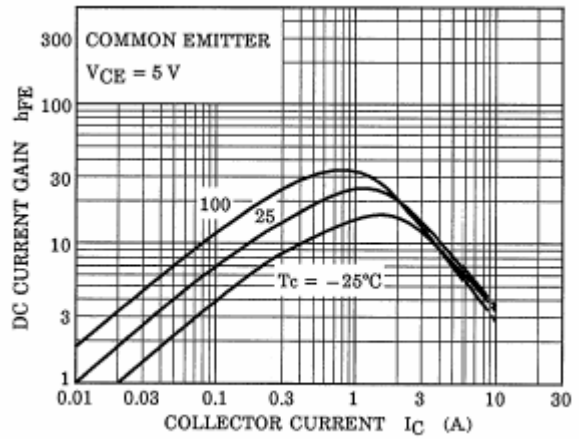

Fig.4 DC current Gain

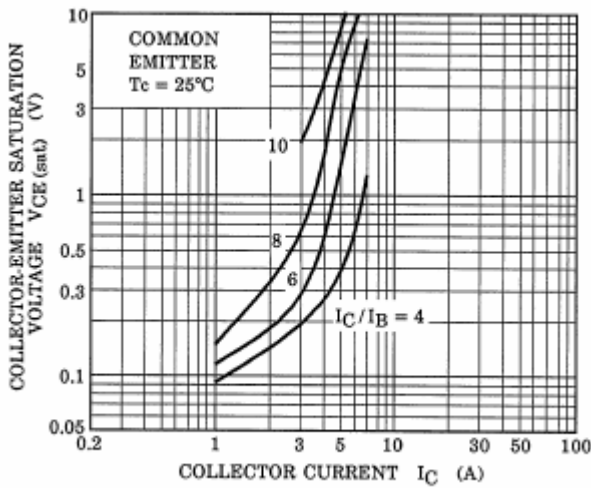

Fig.5 Collector-Emitter Saturation Voltage

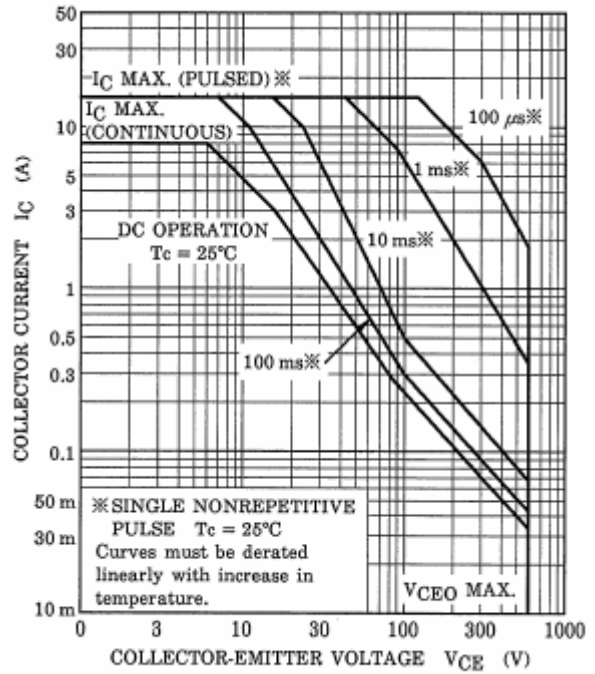

Fig.6 Safe Operating Area