

**IN74ACT112**

**Dual J-K Flip-Flop  
with Set and Reset**

**High-Speed Silicon-Gate CMOS**

The IN74ACT112 is identical in pinout to the LS/ALS112, HC/HCT112. The IN74ACT112 may be used as a level converter for interfacing TTL or NMOS outputs to High Speed CMOS inputs.

Each flip-flop is negative-edge clocked and has active-low asynchronous Set and Reset inputs.

- TTL/NMOS Compatible Input Levels
- Outputs Directly Interface to CMOS, NMOS, and TTL
- Operating Voltage Range: 4.5 to 5.5 V
- Low Input Current: 1.0  $\mu$ A; 0.1  $\mu$ A @ 25°C
- Outputs Source/Sink 24 mA

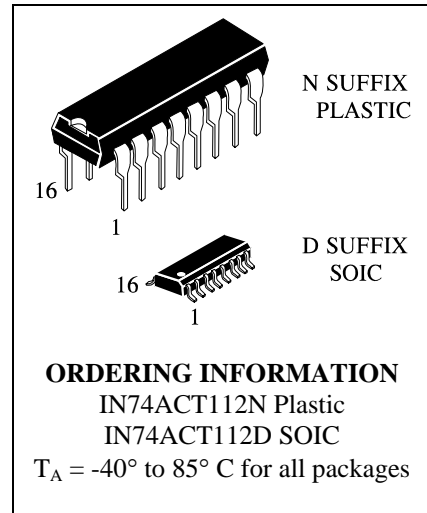

**LOGIC DIAGRAM**

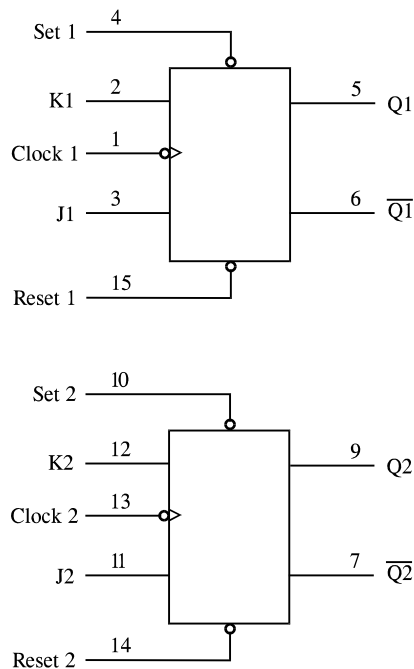

PIN 16 = V<sub>CC</sub>  
 PIN 8 = GND

**PIN ASSIGNMENT**

|         |   |    |                 |
|---------|---|----|-----------------|
| CLOCK 1 | 1 | 16 | V <sub>CC</sub> |
| K1      | 2 | 15 | RESET 1         |
| J1      | 3 | 14 | RESET 2         |
| SET 1   | 4 | 13 | CLOCK 2         |
| Q1      | 5 | 12 | K2              |
| Q1-bar  | 6 | 11 | J2              |
| Q2-bar  | 7 | 10 | SET 2           |
| GND     | 8 | 9  | Q2              |

**FUNCTION TABLE**

| Inputs |       |       |   |   | Outputs   |       |
|--------|-------|-------|---|---|-----------|-------|
| Set    | Reset | Clock | J | K | Q         | Q-bar |
| L      | H     | X     | X | X | H         | L     |
| H      | L     | X     | X | X | L         | H     |
| L      | L     | X     | X | X | L*        | L*    |
| H      | H     |       | L | L | No Change |       |
| H      | H     |       | L | H | L         | H     |
| H      | H     |       | H | L | H         | L     |
| H      | H     |       | H | H | Toggle    |       |
| H      | H     | L     | X | X | No Change |       |
| H      | H     | H     | X | X | No Change |       |
| H      | H     |       | X | X | No Change |       |

\* Both outputs will remain low as long as Set and Reset are low, but the output states are unpredictable if Set and Reset go high simultaneously  
 X = Don't Care

**MAXIMUM RATINGS\***

| Symbol           | Parameter  | Value                        | Unit |
|------------------|--|------------------------------|------|
| V <sub>CC</sub>  | DC Supply Voltage (Referenced to GND)  | -0.5 to +7.0                 | V    |
| V <sub>IN</sub>  | DC Input Voltage (Referenced to GND)   | -0.5 to V <sub>CC</sub> +0.5 | V    |
| V <sub>OUT</sub> | DC Output Voltage (Referenced to GND)  | -0.5 to V <sub>CC</sub> +0.5 | V    |
| I <sub>IN</sub>  | DC Input Current, per Pin  | ±20                          | mA   |
| I <sub>OUT</sub> | DC Output Sink/Source Current, per Pin   | ±50                          | mA   |
| I <sub>CC</sub>  | DC Supply Current, V <sub>CC</sub> and GND Pins                                  | ±50                          | mA   |
| P <sub>D</sub>   | Power Dissipation in Still Air, Plastic DIP+<br>SOIC Package+                    | 750<br>500                   | mW   |
| T <sub>stg</sub> | Storage Temperature  | -65 to +150                  | °C   |
| T <sub>L</sub>   | Lead Temperature, 1 mm from Case for 10 Seconds<br>(Plastic DIP or SOIC Package) | 260                          | °C   |

\*Maximum Ratings are those values beyond which damage to the device may occur. Functional operation should be restricted to the Recommended Operating Conditions.

+Derating - Plastic DIP: - 10 mW/°C from 65° to 125°C  
SOIC Package: - 7 mW/°C from 65° to 125°C

**RECOMMENDED OPERATING CONDITIONS**

| Symbol                             | Parameter   | Min  | Max             | Unit |
|------------------------------------|---|--|-----------------|------|
| V <sub>CC</sub>                    | DC Supply Voltage (Referenced to GND)                 | 4.5  | 5.5             | V    |
| V <sub>IN</sub> , V <sub>OUT</sub> | DC Input Voltage, Output Voltage (Referenced to GND)  | 0  | V <sub>CC</sub> | V    |
| T <sub>J</sub>                     | Junction Temperature (PDIP)                           |  | 140             | °C   |
| T <sub>A</sub>                     | Operating Temperature, All Package Types              | -40  | +85             | °C   |
| I <sub>OH</sub>                    | Output Current - High                                 |  | -24             | mA   |
| I <sub>OL</sub>                    | Output Current - Low                                  |  | 24              | mA   |
| t <sub>r</sub> , t <sub>f</sub>    | Input Rise and Fall Time *<br>(except Schmitt Inputs) | V <sub>CC</sub> =4.5 V<br>0<br>V <sub>CC</sub> =5.5 V<br>0 | 10<br>8.0       | ns/V |

\* V<sub>IN</sub> from 0.8 V to 2.0 V

This device contains protection circuitry to guard against damage due to high static voltages or electric fields. However, precautions must be taken to avoid applications of any voltage higher than maximum rated voltages to this high-impedance circuit. For proper operation, V<sub>IN</sub> and V<sub>OUT</sub> should be constrained to the range GND ≤ (V<sub>IN</sub> or V<sub>OUT</sub>) ≤ V<sub>CC</sub>.

Unused inputs must always be tied to an appropriate logic voltage level (e.g., either GND or V<sub>CC</sub>). Unused outputs must be left open.

**DC ELECTRICAL CHARACTERISTICS** (Voltages Referenced to GND)

| Symbol            | Parameter                                      | Test Conditions  | V <sub>CC</sub><br>V | Guaranteed Limits |                  | Unit |
|-------------------|--|--|----------------------|-------------------|------------------|------|
|                   |  |  |                      | 25 °C             | -40°C to<br>85°C |      |
| V <sub>IH</sub>   | Minimum High-Level Input Voltage               | V <sub>OUT</sub> =0.1 V or V <sub>CC</sub> - 0.1 V                               | 4.5<br>5.5           | 2.0<br>2.0        | 2.0<br>2.0       | V    |
| V <sub>IL</sub>   | Maximum Low - Level Input Voltage              | V <sub>OUT</sub> =0.1 V or V <sub>CC</sub> - 0.1 V                               | 4.5<br>5.5           | 0.8<br>0.8        | 0.8<br>0.8       | V    |
| V <sub>OH</sub>   | Minimum High-Level Output Voltage              | I <sub>OUT</sub> ≤ -50 μA  | 4.5<br>5.5           | 4.4<br>5.4        | 4.4<br>5.4       | V    |
|                   |  | *V <sub>IN</sub> = V <sub>IL</sub> or V <sub>IH</sub><br>I <sub>OH</sub> =-24 mA | 4.5                  | 3.86              | 3.76             |      |
|                   |  | I <sub>OH</sub> =-24 mA  | 5.5                  | 4.86              | 4.76             |      |
| V <sub>OL</sub>   | Maximum Low-Level Output Voltage               | I <sub>OUT</sub> ≤ 50 μA   | 4.5<br>5.5           | 0.1<br>0.1        | 0.1<br>0.1       | V    |
|                   |  | *V <sub>IN</sub> = V <sub>IL</sub> or V <sub>IH</sub><br>I <sub>OL</sub> =24 mA  | 4.5                  | 0.36              | 0.44             |      |
|                   |  | I <sub>OL</sub> =24 mA   | 5.5                  | 0.36              | 0.44             |      |
| I <sub>IN</sub>   | Maximum Input Leakage Current                  | V <sub>IN</sub> =V <sub>CC</sub> or GND  | 5.5                  | ±0.1              | ±1.0             | μA   |
| ΔI <sub>CCT</sub> | Additional Max I <sub>CC</sub> /Input          | V <sub>IN</sub> =V <sub>CC</sub> - 2.1 V   | 5.5                  |                   | 1.5              | mA   |
| I <sub>OLD</sub>  | +Minimum Dynamic Output Current                | V <sub>OLD</sub> =1.65 V Max   | 5.5                  |                   | 75               | mA   |
| I <sub>OHD</sub>  | +Minimum Dynamic Output Current                | V <sub>OHD</sub> =3.85 V Min   | 5.5                  |                   | -75              | mA   |
| I <sub>CC</sub>   | Maximum Quiescent Supply Current (per Package) | V <sub>IN</sub> =V <sub>CC</sub> or GND  | 5.5                  | 4.0               | 40               | μA   |

\* All outputs loaded; thresholds on input associated with output under test.

+Maximum test duration 2.0 ms, one output loaded at a time.

**AC ELECTRICAL CHARACTERISTICS** ( $V_{CC}=5.0\text{ V} \pm 10\%$ ,  $C_L=50\text{pF}$ , Input  $t_r=t_f=3.0\text{ ns}$ )

| Symbol    | Parameter   | Guaranteed Limits |      |               |      | Unit |
|-----------|---|-------------------|------|---------------|------|------|
|           |   | 25 °C             |      | -40°C to 85°C |      |      |
|           |   | Min               | Max  | Min           | Max  |      |
| $f_{max}$ | Maximum Clock Frequency (Figure 1)                                  | 145               |      | 125           |      | MHz  |
| $t_{PLH}$ | Propagation Delay, Clock to $\overline{Q}$ or $Q$ (Figure 1)        | 1.0               | 14.0 | 1.0           | 15.0 | ns   |
| $t_{PHL}$ | Propagation Delay, Clock to $\overline{Q}$ or $Q$ (Figure 1)        | 1.0               | 14.0 | 1.0           | 14.5 | ns   |
| $t_{PLH}$ | Propagation Delay, Set or Reset to $\overline{Q}$ or $Q$ (Figure 2) | 1.0               | 12.0 | 1.0           | 12.5 | ns   |
| $t_{PHL}$ | Propagation Delay, Set or Reset to $\overline{Q}$ or $Q$ (Figure 2) | 1.0               | 12.5 | 1.0           | 13.0 | ns   |
| $C_{IN}$  | Maximum Input Capacitance   | 4.5               |      | 4.5           |      | pF   |

|          |                               |                                      |  |  |  |    |
|----------|-------------------------------|--------------------------------------|--|--|--|----|
| $C_{PD}$ | Power Dissipation Capacitance | Typical @25°C, $V_{CC}=5.0\text{ V}$ |  |  |  | pF |
|          |                               | 35                                   |  |  |  |    |

**TIMING REQUIREMENTS**( $V_{CC}=5.0\text{ V} \pm 10\%$ ,  $C_L=50\text{pF}$ , Input  $t_r=t_f=3.0\text{ ns}$ )

| Symbol    | Parameter   | Guaranteed Limits |               | Unit |
|-----------|---|-------------------|---------------|------|
|           |   | 25 °C             | -40°C to 85°C |      |
| $t_{su}$  | Minimum Setup Time, J or K to Clock (Figure 3)          | 2.0               | 2.5           | ns   |
| $t_h$     | Minimum Hold Time, Clock to J or K (Figure 3)           | 2.0               | 2.0           | ns   |
| $t_w$     | Minimum Pulse Width, Clock (Figure 1)                   | 5.0               | 6.0           | ns   |
| $t_w$     | Minimum Pulse Width, Set or Reset (Figure 2)            | 5.5               | 6.0           | ns   |
| $t_{rec}$ | Minimum Recovery Time, Set or Reset to Clock (Figure 2) | 0                 | 0             | ns   |

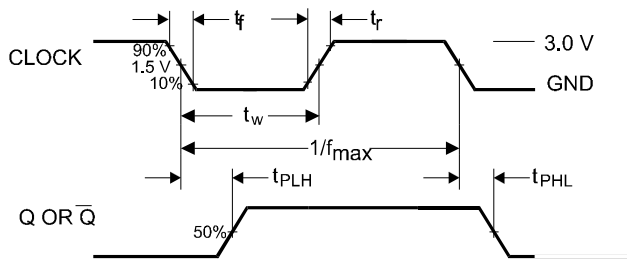

Figure 1. Switching Waveform

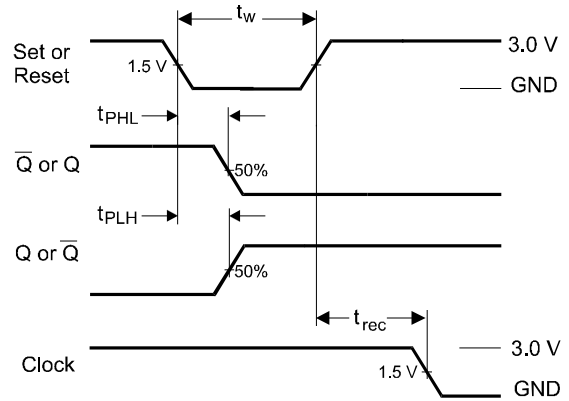

Figure 2. Switching Waveform

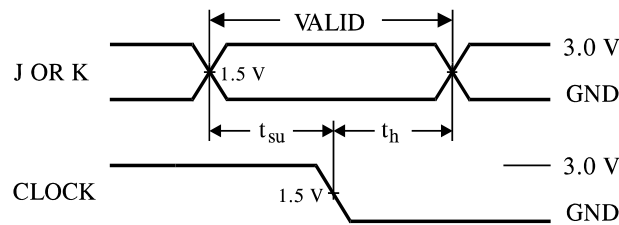
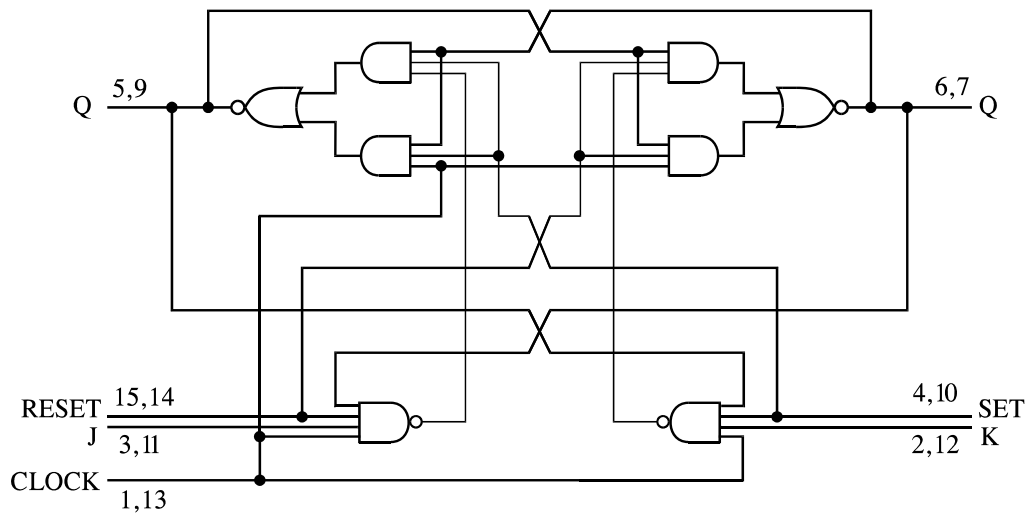
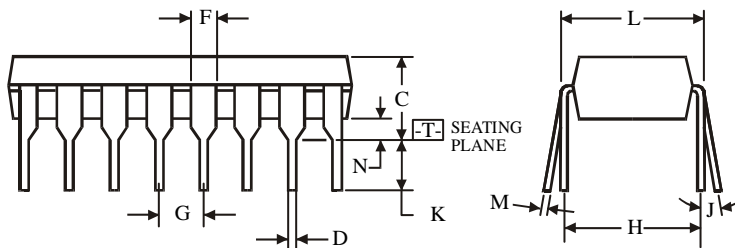
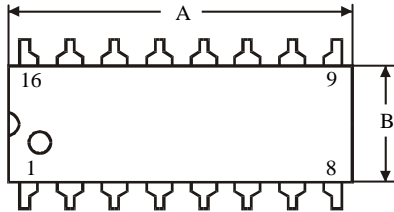
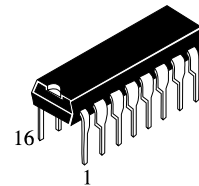

Figure 3. Switching Waveform

EXPANDED LOGIC DIAGRAM



**N SUFFIX PLASTIC DIP  
(MS - 001BB)**



$\oplus 0.25 (0.010) \text{ (M) T}$

**NOTES:**

- Dimensions "A", "B" do not include mold flash or protrusions.  
Maximum mold flash or protrusions 0.25 mm (0.010) per side.

| Symbol | Dimension, mm |       |
|--------|---------------|-------|
|        | MIN           | MAX   |
| A      | 18.67         | 19.69 |
| B      | 6.1           | 7.11  |
| C      |               | 5.33  |
| D      | 0.36          | 0.56  |
| F      | 1.14          | 1.78  |
| G      | 2.54          |       |
| H      | 7.62          |       |
| J      | 0°            | 10°   |
| K      | 2.92          | 3.81  |
| L      | 7.62          | 8.26  |
| M      | 0.2           | 0.36  |
| N      | 0.38          |       |

**D SUFFIX SOIC  
(MS - 012AC)**

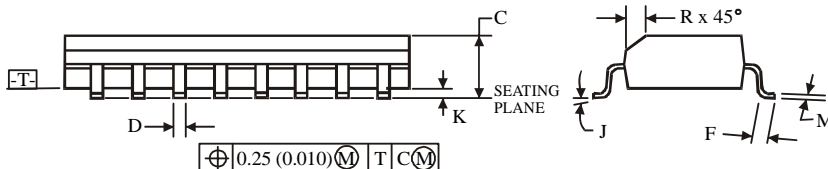
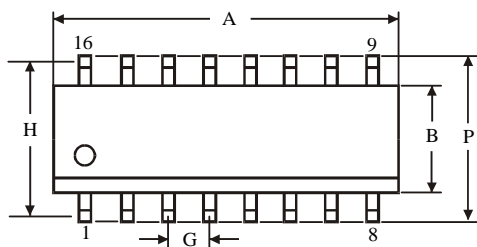
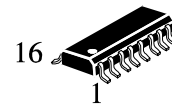

$\oplus 0.25 (0.010) \text{ (M) T C (M)}$

**NOTES:**

- Dimensions A and B do not include mold flash or protrusion.
- Maximum mold flash or protrusion 0.15 mm (0.006) per side for A; for B - 0.25 mm (0.010) per side.

| Symbol | Dimension, mm |      |
|--------|---------------|------|
|        | MIN           | MAX  |
| A      | 9.8           | 10   |
| B      | 3.8           | 4    |
| C      | 1.35          | 1.75 |
| D      | 0.33          | 0.51 |
| F      | 0.4           | 1.27 |
| G      | 1.27          |      |
| H      | 5.72          |      |
| J      | 0°            | 8°   |
| K      | 0.1           | 0.25 |
| M      | 0.19          | 0.25 |
| P      | 5.8           | 6.2  |
| R      | 0.25          | 0.5  |