

Silicon NPN Power Transistors

2SD2400

DESCRIPTION

- With TO-220F package
- Complement to type 2SB1569
- High transition frequency
- Collector power dissipation:
 $P_C=20W(T_C=25)$

APPLICATIONS

- For low frequency power amplifier applications

PINNING

PIN	DESCRIPTION
1	Base
2	Collector
3	Emitter

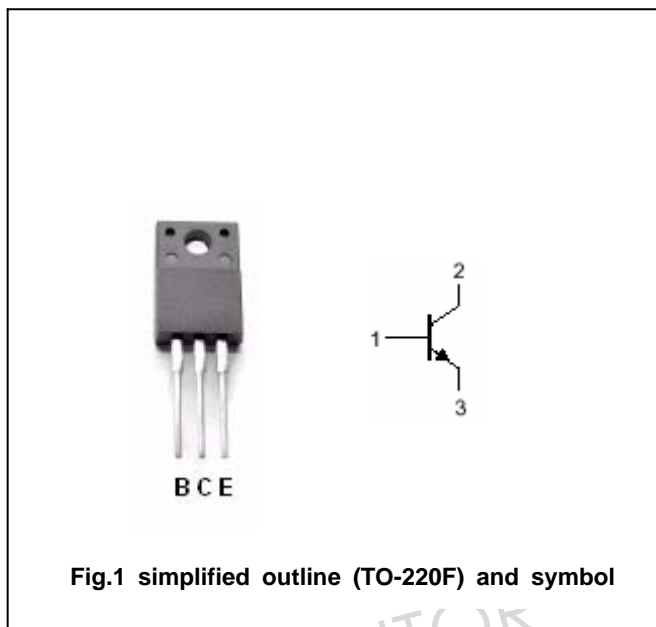

Absolute maximum ratings ($T_a=25$)

SYMBOL	PARAMETER	CONDITIONS	VALUE	UNIT
V_{CBO}	Collector-base voltage	Open emitter	120	V
V_{CEO}	Collector-emitter voltage	Open base	120	V
V_{EBO}	Emitter-base voltage	Open collector	5	V
I_C	Collector current		1.5	A
I_{CM}	Collector current-peak		3	A
P_C	Collector dissipation	$T_a=25$	2.0	W
		$T_C=25$	20	
T_j	Junction temperature		150	
T_{stg}	Storage temperature		-55~150	

Silicon NPN Power Transistors

2SD2400

CHARACTERISTICS

T_j=25 unless otherwise specified

SYMBOL	PARAMETER	CONDITIONS	MIN	TYP.	MAX	UNIT
V _{(BR)CEO}	Collector-emitter breakdown voltage	I _C =1mA ; I _B =0	120			V
V _{(BR)CBO}	Collector-base breakdown voltage	I _C =50 μ A ; I _E =0	120			V
V _{(BR)EBO}	Emitter-base breakdown voltage	I _E =50 μ A ; I _C =0	5			V
V _{CEsat}	Collector-emitter saturation voltage	I _C =1A ; I _B =0.1A			2.0	V
V _{BEsat}	Base-emitter saturation voltage	I _C =1A ; I _B =0.1A			1.5	V
I _{CBO}	Collector cut-off current	V _{CB} =120V ; I _E =0			1.0	μ A
I _{EBO}	Emitter cut-off current	V _{EB} =4V ; I _C =0			1.0	μ A
h _{FE}	DC current gain	I _C =0.1A ; V _{CE} =5V	60		320	
f _T	Transition frequency	I _C =0.1A ; V _{CE} =5V ; f=30MHz		80		MHz
C _{OB}	Collector output capacitance	I _E =0 ; V _{CB} =10V ; f=1MHz		20		pF

◆ h_{FE} Classifications

D	E	F
60-120	100-200	160-320

Silicon NPN Power Transistors

2SD2400

PACKAGE OUTLINE

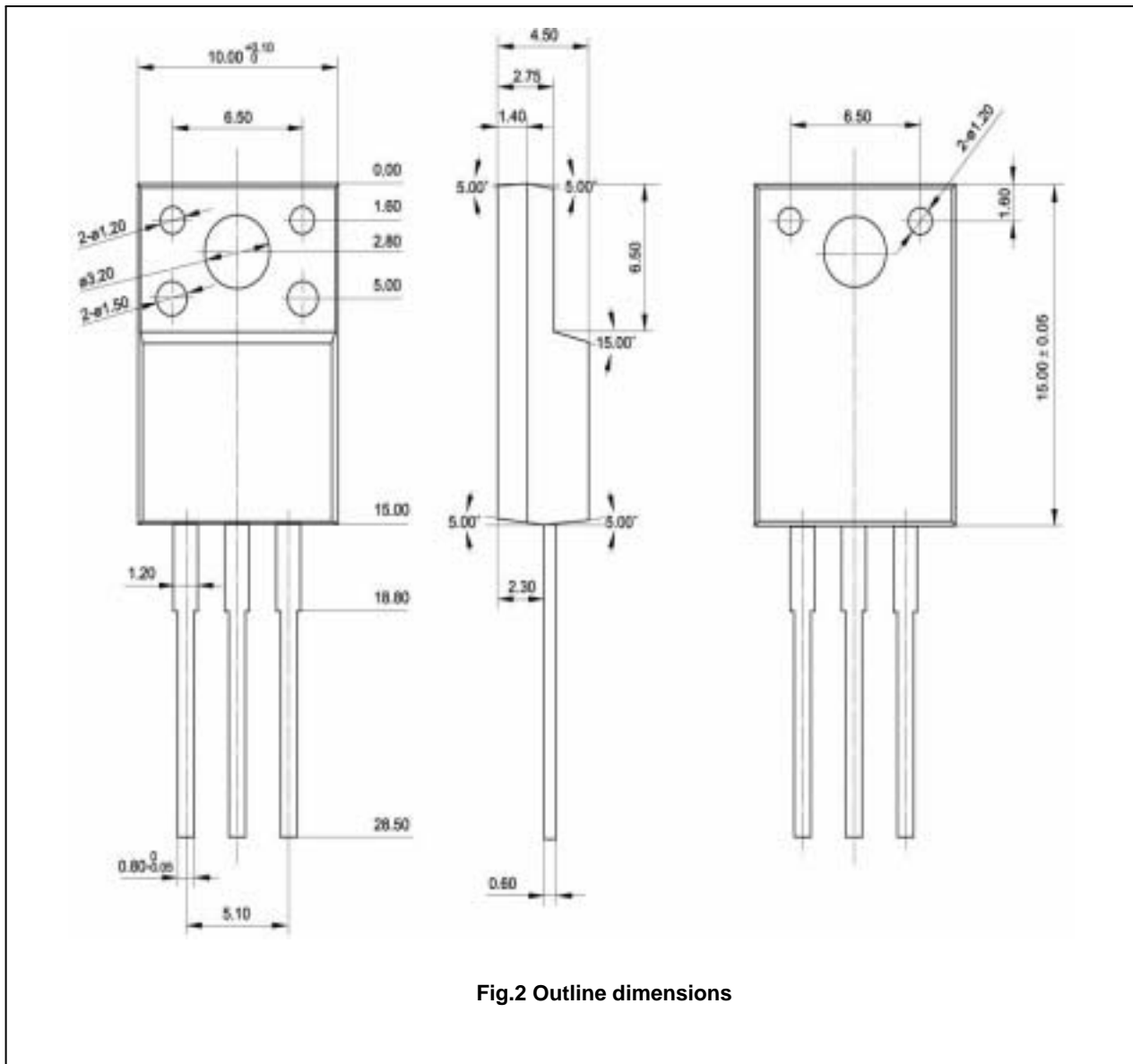

Fig.2 Outline dimensions