

isc Silicon NPN Power Transistor

KSD362

DESCRIPTION

- Collector-Base Breakdown Voltage-
: $V_{(BR)CBO} = 150V(\text{Min})$
- Collector Current- $I_C = 5A$
- Collector Power Dissipation-
: $P_C = 40W @ T_C = 25^\circ C$

APPLICATIONS

- Designed for B/W TV horizontal deflection output applications.

ABSOLUTE MAXIMUM RATINGS($T_a=25^\circ C$)

SYMBOL	PARAMETER	VALUE	UNIT
V_{CBO}	Collector-Base Voltage	150	V
V_{CEO}	Collector-Emitter Voltage	70	V
V_{EBO}	Emitter-Base Voltage	8	V
I_C	Collector Current-Continuous	5	A
P_C	Collector Power Dissipation @ $T_C=25^\circ C$	40	W
T_J	Junction Temperature	150	$^\circ C$
T_{stg}	Storage Temperature Range	-55~150	$^\circ C$

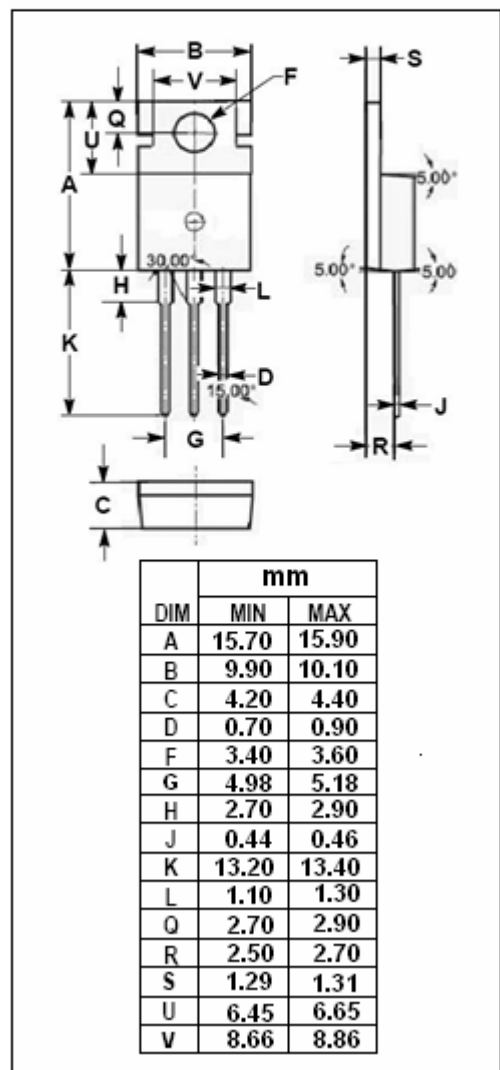
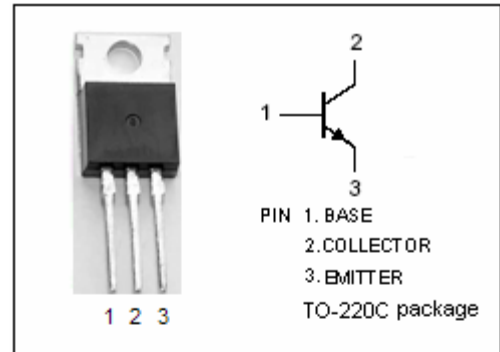

isc Silicon NPN Power Transistor**KSD362****ELECTRICAL CHARACTERISTICS** $T_C=25^{\circ}\text{C}$ unless otherwise specified

SYMBOL	PARAMETER	CONDITIONS	MIN	TYP.	MAX	UNIT
$V_{(BR)CEO}$	Collector-Emitter Breakdown Voltage	$I_C=2\text{mA}; R_{BE}=\infty$	70			V
$V_{(BR)CBO}$	Collector-Base Breakdown Voltage	$I_C=1\text{mA}; I_E=0$	150			V
$V_{(BR)EBO}$	Emitter-Base Breakdown Voltage	$I_E=1\text{mA}; I_C=0$	8			
$V_{CE(sat)}$	Collector-Emitter Saturation Voltage	$I_C=5\text{A}; I_B=0.5\text{A}$			1.0	V
$V_{BE(sat)}$	Base-Emitter Saturation Voltage	$I_C=5\text{A}; I_B=0.5\text{A}$			1.5	V
I_{CBO}	Collector Cutoff Current	$V_{CB}=100\text{V}; I_E=0$			20	μA
h_{FE}	DC Current Gain	$I_C=5\text{A}; V_{CE}=5\text{V}$	20		140	
f_T	Current-Gain—Bandwidth Product	$I_C=0.5\text{A}; V_{CE}=5\text{V}$		10		MHz

◆ **h_{FE} Classifications**

N	R	O
20-50	40-80	70-140