

Silicon NPN Power Transistors

MJE18002

DESCRIPTION

- With TO-220 package
- High voltage ,high speed

APPLICATIONS

- Designed for use in 220V line-operated switchmode power supplies and electronic light ballast

PINNING

PIN	DESCRIPTION
1	Base
2	Collector
3	Emitter

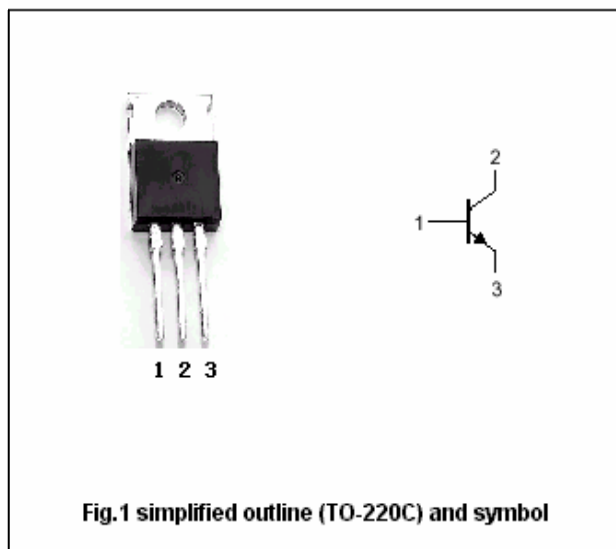
Absolute maximum ratings($T_c=25$)

SYMBOL	PARAMETER	CONDITIONS	VALUE	UNIT
V_{CBO}	Collector-base voltage	Open emitter	1000	V
V_{CEO}	Collector-emitter voltage	Open base	450	V
V_{EBO}	Emitter-base voltage	Open collector	9	V
I_C	Collector current (DC)		2	A
I_{CM}	Collector current-Peak		5	A
I_B	Base current		0.5	A
I_{BM}	Base current-Peak		1.0	A
P_D	Total power dissipation	$T_c=25$	100	W
T_j	Junction temperature		150	
T_{stg}	Storage temperature		-65~150	

THERMAL CHARACTERISTICS

SYMBOL	PARAMETER	MAX	UNIT
$R_{th j-C}$	Thermal resistance junction to case	1.25	/W
$R_{th j-A}$	Thermal resistance junction to ambient	62.5	/W

Silicon NPN Power Transistors

MJE18002

CHARACTERISTICS

T_j=25 unless otherwise specified

SYMBOL	PARAMETER	CONDITIONS	MIN	TYP.	MAX	UNIT	
V _{CEO(SUS)}	Collector-emitter sustaining voltage	I _C =0.1A; L=25mH	450			V	
V _{CEsat-1}	Collector-emitter saturation voltage	I _C =0.4A; I _B =40mA T _C =125			0.5 0.5	V	
V _{CEsat-2}	Collector-emitter saturation voltage	I _C =1A; I _B =0.2A T _C =125			0.5 0.6	V	
V _{BEsat-1}	Base-emitter saturation voltage	I _C =0.4A; I _B =40mA			1.1	V	
V _{BEsat-2}	Base-emitter saturation voltage	I _C =1A; I _B =0.2A			1.25	V	
I _{CES}	Collector cut-off current	V _{CE} =RatedV _{CE} ; V _{EB} =0	T _C =125			0.1	mA
						0.5	
		V _{CE} =800V				0.1	
I _{CEO}	Collector cut-off current	V _{CE} =RatedV _{CE} ; I _B =0			0.1	mA	
I _{EBO}	Emitter cut-off current	V _{EB} =9V; I _C =0			0.1	mA	
h _{FE-1}	DC current gain	I _C =0.2A; V _{CE} =5V	14		34		
h _{FE-2}	DC current gain	I _C =0.4A; V _{CE} =1V	11				
h _{FE-3}	DC current gain	I _C =1A; V _{CE} =1V	6				
h _{FE-4}	DC current gain	I _C =10mA; V _{CE} =5V	10				
f _T	Transition frequency	I _C =0.5A; V _{CE} =10V; f=1.0MHz		6.5		MHz	
C _{OB}	Collector output capacitance	I _E =0; V _{CB} =10V; f=1.0MHz		35		pF	

Switching times resistive load, Duty Cycle 10%, Pulse Width=20 μs

t _{on}	Turn-on time	V _{CC} =300V, I _C =0.4A I _{B1} =40mA; I _{B2} =0.2A		200	300	ns
t _{off}	Turn-off time			1.2	2.5	μs
t _{on}	Turn-on time	V _{CC} =300V, I _C =1.0A I _{B1} =0.2A; I _{B2} =0.5A		85	150	ns
t _{off}	Turn-off time			1.7	2.5	μs

PACKAGE OUTLINE

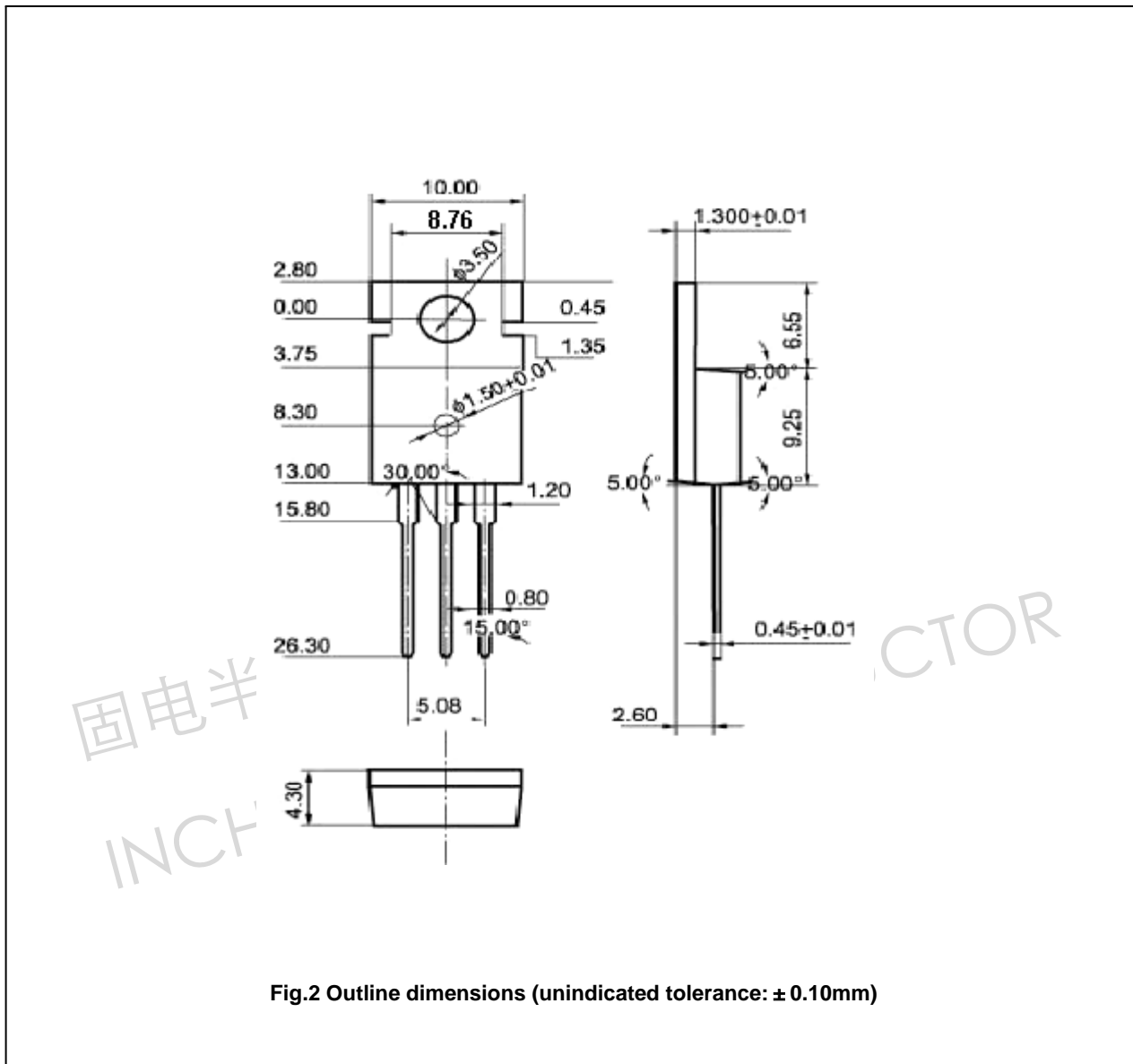

Fig.2 Outline dimensions (unindicated tolerance: ± 0.10mm)