

Silicon NPN Power Transistors

2SC1904

DESCRIPTION

- With TO-126 package
- Complement to type 2SA899

APPLICATIONS

- For high frequency power amplification

PINNING

PIN	DESCRIPTION
1	Emitter
2	Collector;connected to mounting base
3	Base

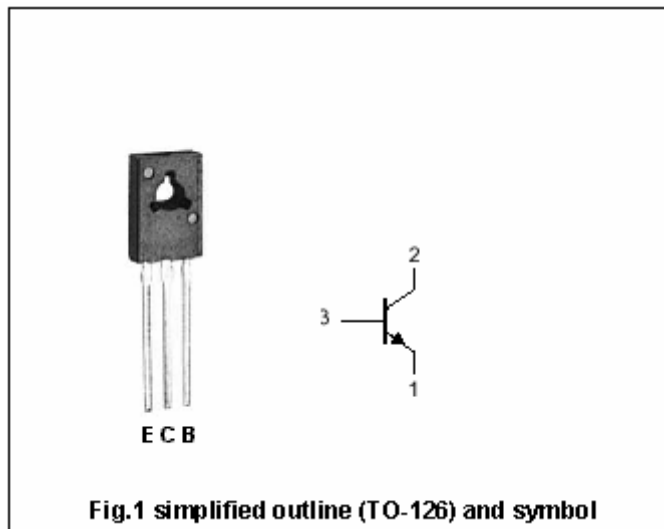
Absolute maximum ratings($T_a=25^{\circ}\text{C}$)

SYMBOL	PARAMETER	CONDITIONS	VALUE	UNIT
V_{CB0}	Collector-base voltage	Open emitter	150	V
V_{CEO}	Collector-emitter voltage	Open base	150	V
V_{EBO}	Emitter-base voltage	Open collector	5	V
I_C	Collector current (DC)		50mA	A
P_D	Total power dissipation	$T_C=25^{\circ}\text{C}$	1	W
T_j	Junction temperature		150	$^{\circ}\text{C}$
T_{stg}	Storage temperature		-55~150	$^{\circ}\text{C}$

Silicon NPN Power Transistors

2SC1904

CHARACTERISTICS

T_j=25°C unless otherwise specified

SYMBOL	PARAMETER	CONDITIONS	MIN	TYP.	MAX	UNIT
V _{(BR)CEO}	Collector-emitter breakdown voltage	I _C =1mA; R _{BE} =∞	150			V
V _{(BR)CBO}	Collector-base breakdown voltage	I _C =10 μ A ; I _E =0	150			V
V _{(BR)EBO}	Emitter-base breakdown voltage	I _E =10 μ A ; I _C =0	5			V
V _{CEsat}	Collector-emitter saturation voltage	I _C =10mA ; I _B =1mA			0.5	V
V _{BEsat}	Base-emitter saturation voltage	I _C =10mA ; I _B =1mA			1.0	V
I _{CBO}	Collector cut-off current	V _{CB} =140V; I _E =0			1	μ A
I _{EBO}	Emitter cut-off current	V _{EB} =4V; I _C =0			1	μ A
h _{FE}	DC current gain	I _C =10mA ; V _{CE} =5V	35		500	
C _{OB}	Output capacitance	I _E =0 ; V _{CB} =10V; f=1MHz		3		pF
f _T	Transition frequency	I _C =10mA ; V _{CE} =5V		70		MHz

PACKAGE OUTLINE

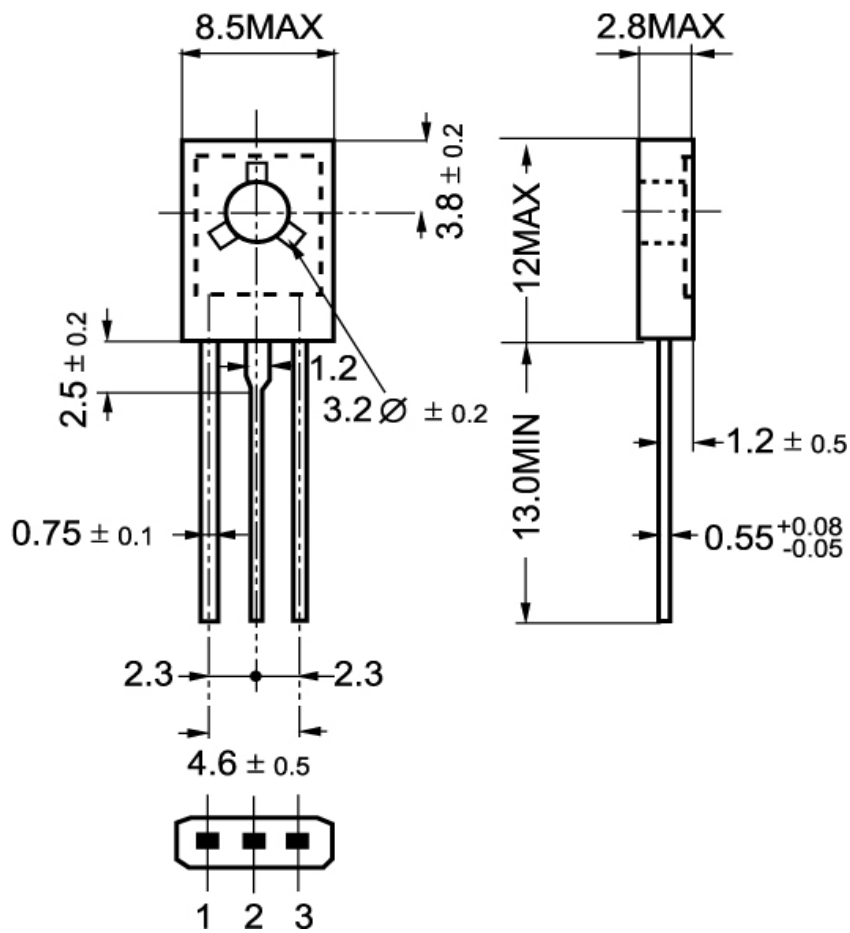

Fig.2 Outline dimensions