

Silicon NPN Power Transistors

2SC515

DESCRIPTION

- With TO-66 package
- High breakdown voltage

APPLICATIONS

- For use in line-operated color TV chroma output circuits and sound output circuits

PINNING(see Fig.2)

PIN	DESCRIPTION
1	Base
2	Emitter
3	Collector

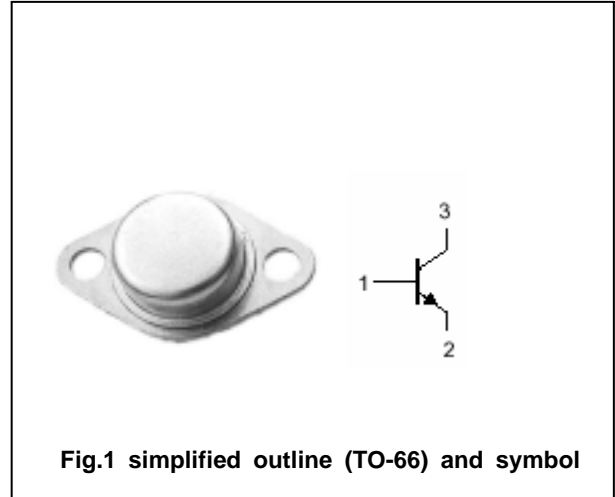

Fig.1 simplified outline (TO-66) and symbol

Absolute maximum ratings($T_a =$)

SYMBOL	PARAMETER	CONDITIONS	VALUE	UNIT
V_{CBO}	Collector-base voltage	Open emitter	300	V
V_{CEO}	Collector-emitter voltage	Open base	300	V
V_{EBO}	Emitter-base voltage	Open collector	7	V
I_C	Collector current		0.1	A
P_D	Total power dissipation	$T_C=25$	6	W
T_j	Junction temperature		150	
T_{stg}	Storage temperature		-55~150	

Silicon NPN Power Transistors

2SC515

CHARACTERISTICS

T_j=25 unless otherwise specified

SYMBOL	PARAMETER	CONDITIONS	MIN	TYP.	MAX	UNIT
V _{(BR)CEO}	Collector-emitter breakdown voltage	I _C =1mA; I _B =0	300			V
V _{(BR)CBO}	Collector-base breakdown voltage	I _C =10 μ A; I _E =0	300			V
V _{(BR)EBO}	Emitter-base breakdown voltage	I _E =10 μ A; I _C =0	7			V
V _{CEsat}	Collector-emitter saturation voltage	I _C =50mA; I _B =5m A			2.0	V
I _{CBO}	Collector cut-off current	V _{CB} =200V; I _E =0			100	nA
I _{EBO}	Emitter cut-off current	V _{EB} =5V; I _C =0			100	nA
h _{FE}	DC current gain	I _C =50mA ; V _{CE} =10V	30		150	

PACKAGE OUTLINE

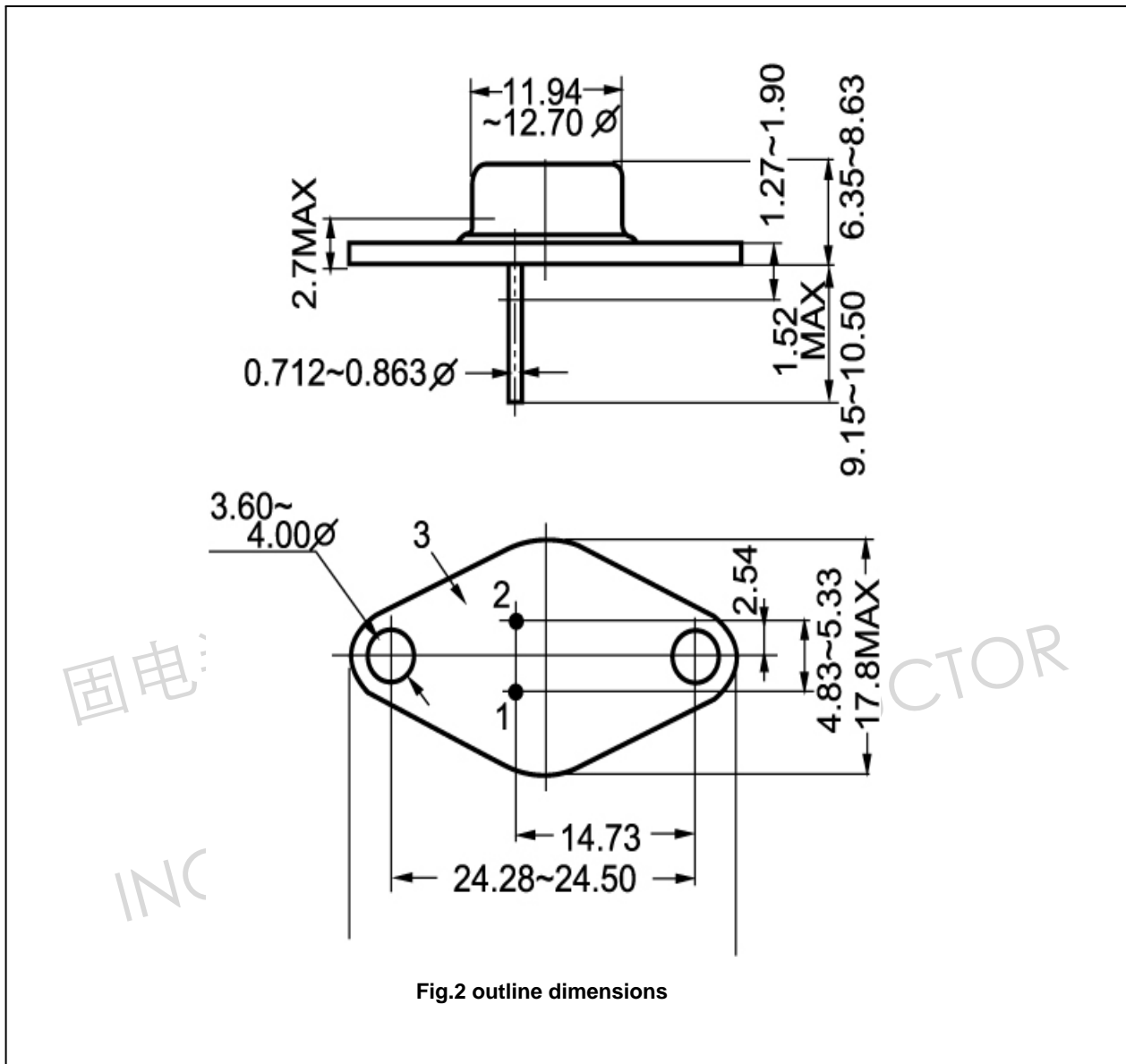

Fig.2 outline dimensions