

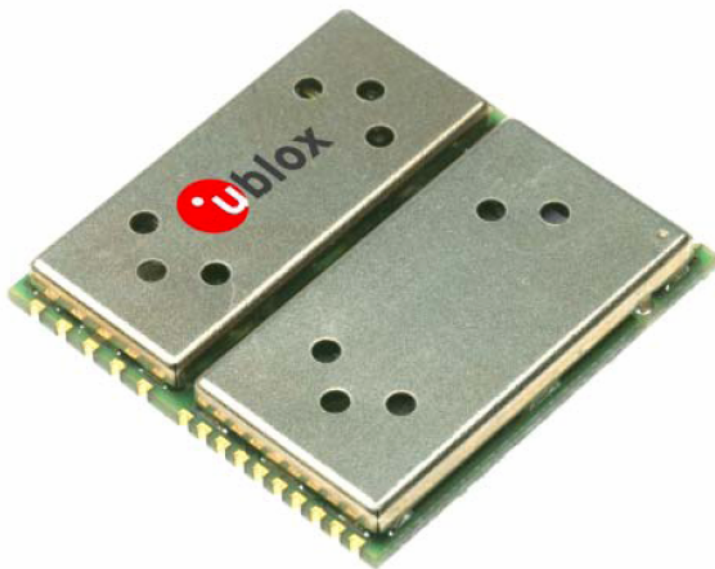

TIM-LC GPS Receiver Module

Data Sheet



Abstract

This document describes the features and specifications of the TIM-LC module suitable for active antennas. Based on the ANTARIS® GPS technology, it offers best GPS performance at very low power consumption.

your position is our focus

Data Sheet

Title	TIM-LC		
Subtitle	GPS Receiver Module		
Doc Type	Data Sheet		
Doc Id	GPS.G3-MS3-03019-D		
Revision Index	Date	Name	Status / Comments
P1	2. Apr. 03	GzB	Preliminary release
P2	16. Jun. 03	GzB	Updated electrical and performance characteristics
P3	30. Oct. 03	GzB	New: Section 1.8 (Antenna), table 5 (Timepulse accuracy), table 9 (sleep mode current)
P4	21. Nov. 03	GzB	Modified sections 1.1, 1.3 and Table 6
- (Initial Release)	07. May 04	GzB	Modified Table 3 and Section 5
A	6. July 04	GzB	Updated ordering information
B	6. Aug. 04	GzB	Modified Table 10: Sustained supply current; Modified sections 1.1, 1.2, 3.1, 3.3, Table 10 and 6.1 because serial port 2 is available
C	15. Se.p 04	GzB	Modified section 1.8
D	02. Feb. 06	GzB	Modified section 1.8, table 7 (RESET_N)

We reserve all rights in this document and in the information contained therein. Reproduction, use or disclosure to third parties without express authority is strictly forbidden.

For most recent documents, please visit www.u-blox.com

Data Sheet Revisions	Identification of applicable hardware	Comments
P1 - P3	TIM-LC with data codes 130100.0211.000, 130100.0311.000	ANTARIS GPS Firmware Version 2.11 inside
P4, -, A	TIM-LC with data codes 130100.0320.000, 130100.0420.000	ANTARIS GPS Firmware Version 3.0 inside
B, C, D	TIM-LC with data codes 130100.0500.000 and higher	ANTARIS Chipset with ROM 3.0

	<p>Products marked with this lead-free symbol on the product label comply with the "Directive 2002/95/EC of the European Parliament and the Council on the Restriction of Use of certain Hazardous Substances in Electrical and Electronic Equipment" (RoHS).</p>
---	---

The specifications in this document are subject to change at u-blox' discretion. u-blox assumes no responsibility for any claims or damages arising out of the use of this document, or from the use of modules based on this document, including but not limited to claims or damages based on infringement of patents, copyrights or other intellectual property rights. u-blox makes no warranties, either expressed or implied with respect to the information and specifications contained in this document. u-blox does not support any applications in connection with active weapon systems, ammunition, life support and commercial aircraft. Performance characteristics listed in this document are estimates only and do not constitute a warranty or guarantee of product performance.

The copying, distribution and utilization of this document as well as the communication of its contents to others without expressed authorization is prohibited. Offenders will be held liable for the payment of damages. All rights reserved, in particular the right to carry out patent, utility model and ornamental design registrations.

u-blox, the u-blox logo, the TIM type GPS module, Antaris, SuperSense, "your position is our focus", NavLox, u-center, FixNow and EKF are (registered) trademarks of u-blox AG. The u-blox software as well as the design of the LEA type modules is protected by intellectual property rights in Switzerland and abroad. Further information available at info@u-blox.com. Copyright © 2006, u-blox AG

Contents

1	Functional Description	4
1.1	Overview	4
1.2	Block Diagram	4
1.3	Benefits	5
1.4	Features	5
1.5	Operating Modes	6
1.6	Protocols	6
1.7	Boot-Time GPSMODE Configuration	7
1.8	Antenna	8
2	Performance Specification	9
3	Mechanical Specification	10
3.1	Dimensions	10
3.2	Specification	10
3.3	Pinout	11
4	Electrical Specification	12
4.1	Absolute Maximum Ratings	12
4.2	Operating Conditions	12
5	Environmental Specification	14
6	Product Lineup	15
6.1	Default Settings	15
6.2	Ordering Information	15

1 Functional Description

1.1 Overview

The TIM-LC is an ultra-low power OEM GPS module suitable for active antennas to run standard PVT applications. It provides two 3V (5V TTL input compatible) serial ports and easy-to-use boot time configuration pins. The combination of lowest power consumption, cost-optimized architecture (no Flash EPROM inside) and innovative packaging technology makes the TIM-LC suitable for high-volume applications where small size, low cost and simplicity are key issues.

The leading ANTARIS[®] GPS Engine, jointly developed by Atmel and u-blox, provides excellent navigation performance under dynamic conditions in areas with limited sky view like urban canyons, high sensitivity for weak signal operation without compromising accuracy, and support of DGPS and multiple SBAS systems like WAAS and EGNOS. The 16 parallel channels and 8192 search bins provide fast start-up times. The aiding functionality accelerates start-up times even further. The low power consumption and FixNow[™] power saving mode make this product suitable for handheld and battery-operated devices.

Innovative packaging technologies enable high integration of a GPS receiver in a small module measuring just 25.4 x 25.4 mm and allowing straightforward integration in particularly small end products and new application fields. The small form factor and the SMT pads allow a fully automatic assembly process with standard pick-and-place equipment and reflow soldering, enabling cost-efficient high-volume production.

1.2 Block Diagram

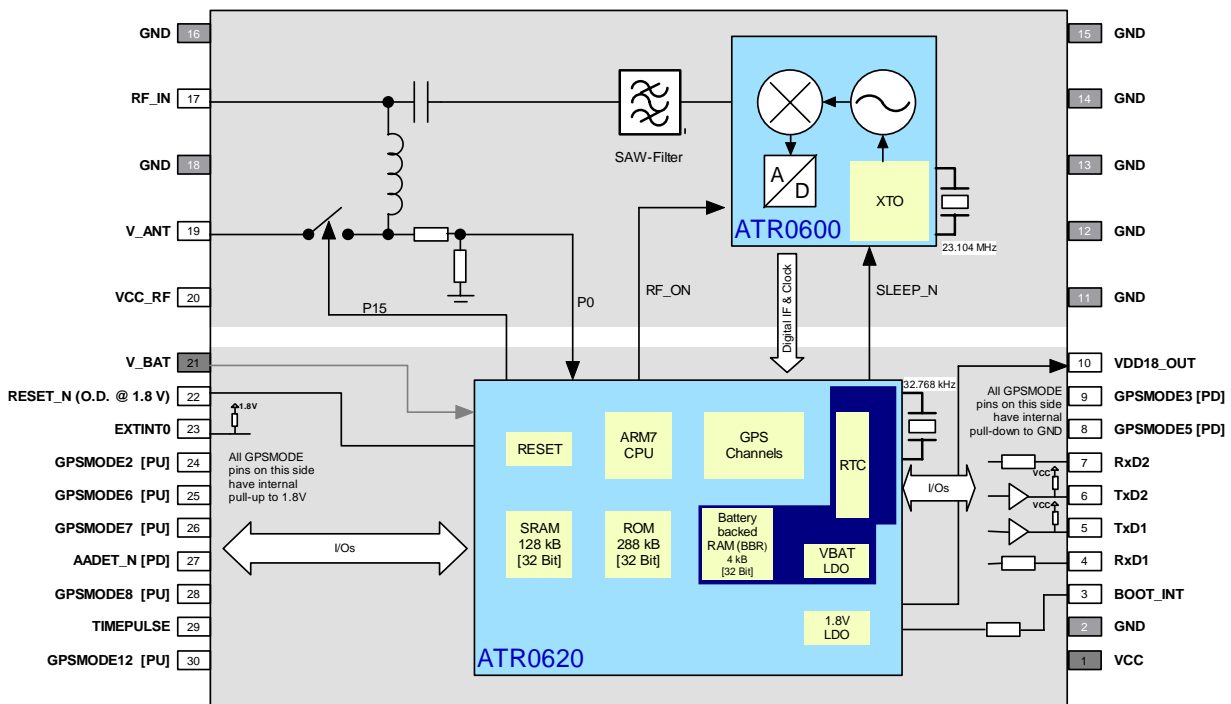

Figure 1: Block Diagram

1.3 Benefits

- High acquisition and tracking sensitivity
- Ultra-low power consumption
- Excellent GPS performance
 - Excellent navigation accuracy, even at low signal levels
 - Active multipath detection and removal
 - Fast Time-To-First-Fix (TTFF)
 - Accelerated TTFF with aiding functionality
- No Flash EPROM inside
 - Independence from memory market and price fluctuations
- Highly integrated GPS module
 - Automatic pick and place assembly
 - Reflow solderable
- Maximum flexibility
 - Extensively configurable
 - Boot-time configuration pins
- Fully EMI shielded
- Active antenna support

1.4 Features

- 16 channel GPS receiver
- 8192 simultaneous time-frequency search bins
- 4 Hz position update rate
- ANTARIS Positioning Engine
 - ATR0600 RF front-end IC
 - ATR0620 Baseband IC with ARM7TDMI inside
- DGPS and SBAS (WAAS, EGNOS) support
- FixNOW™ power saving mode
- Operating voltage 2.7 to 3.3 V
- Battery supply pin for internal backup memory and real time clock
- Industrial operating temperature range –40 to 85°C
- Small size
 - Size 25.4mm x 25.4mm
 - Height 3mm
 - Weight 3g

1.5 Operating Modes

The ANTARIS GPS Technology defines the following Operating Modes:

Operating Modes	Description
Continuous Tracking Mode (CTM)	The Continuous Tracking Mode is configured for optimal position accuracy. This mode is optimized for power consumption based on the ANTARIS Autonomous Power Management (APM) saving as parts of the receiver are switched off when they are not required; also the CPU clock speed is reduced when the CPU is not loaded. There is no need for a user to configure this mode as it is built into the architecture of the module.
Power Saving Modes	
FixNOW™ (FXN)	FixNOW™ Mode allows an application a navigation solution on request. It includes additional Power Saving Functions and is the best mode for any Mobile, Tracking Unit application where low power consumption requirements are primary consideration. This mode can be configured to meet application requirements.

Table 1: Operating Modes

For more information see the *ANTARIS System Integration Manual* [1].

1.6 Protocols

The TIM-LC supports different serial protocols.

Protocol	Type	Runs on
NMEA	Input/output, ASCII, 0183, 2.3 (compatible to 3.0)	All Serial ports
UBX	Input/output, binary, u-blox proprietary	All Serial ports
RTCM	Input, message 1,2,3,9	All Serial ports

Table 2: Available Protocols

For specification of the various protocols see the *Protocol Specification* [2].

1.7 Boot-Time GPSMODE Configuration

The TIM-LC provides seven GPSMODE pins which provide boot-time configuration capabilities. These configuration settings will be effective immediately after start-up. Once the TIM-LC has started, the configuration settings may be modified with UBX configuration messages. The modified settings remain effective until power-down or reset. If these settings have been stored in battery-backup RAM (with CFG-CFG message), then the modified configuration will be retained as long backup battery supply is not interrupted.

GPSMODE		GPS sensitivity settings
3	2	
0	0	Reserved
0	1	Fast acquisition mode (default)
1	0	Normal sensitivity mode
1	1	High sensitivity mode

GPSMODE		Navigation rate settings
8	7	
0	0	CTM 2 Hz
0	1	CTM 0.5 Hz
1	0	CTM 4 Hz update rate
1	1	CTM 1 Hz update rate (default)

Table 3: Supported GPSMODE settings (Default settings apply if not connected)

GPSMODE			Baud Rate	Output Message Set
12	6	5		
0	0	0	57.6 Kbaud, UBX	NAV-SOL, NAV-SVINFO NAV-POSECEF, NAV-POSLLH, NAV-STATUS, NAV-DOP, NAV-VELECEF, NAV-VELNED, NAV-TIMEGPS, NAV-TIMEUTC, NAV-CLOCK MON-SCHD, MON-IO, MON-IPC
0	0	1	38.4 Kbaud, UBX	NAV-SOL, NAV-SVINFO NAV-POSECEF, NAV-POSLLH, NAV-STATUS, NAV-DOP, NAV-VELECEF, NAV-VELNED, NAV-TIMEGPS, NAV-TIMEUTC, NAV-CLOCK
0	1	0	19.2 Kbaud, UBX	NAV-SOL, NAV-SVINFO
0	1	1	Autobauding	None. Must be activated explicitly with CFG-PRT / CFG-MSG messages
1	0	0	19.2 Kbaud, NMEA	GGA, RMC, GSA, GSV, GLL, VTG, ZDA, GRS, GST, TXT PUBX00, PUBX03, PUBX04
1	0	1	4.8 Kbaud, NMMA	GGA, RMC, TXT
1	1	0	9.6 Kbaud, NMEA (default)	GGA, RMC, GSA, GSV, GLL, VTG, ZDA, TXT
1	1	1	115.2 Kbaud, UBX	NAV-SOL, NAV-SVINFO NAV-POSECEF, NAV-POSLLH, NAV-STATUS, NAV-DOP, NAV-VELECEF, NAV-VELNED, NAV-TIMEGPS, NAV-TIMEUTC, NAV-CLOCK MON-SCHD, MON-IO, MON-IPC RXM-RAW

Table 4: Supported GPSMODE settings (Default settings apply if not connected)

For more information see the *ANTARIS System Integration Manual* [1].

1.8 Antenna

This GPS receiver is designed for use with active antennas. An antenna supervisor is provided. If activated, the GPS receiver is capable of detecting short circuits to the active antenna by checking the bias voltage level and can shut down the voltage bias immediately. A series resistor is needed in front of the **V_ANT** input. UBX and NMEA messages are provided to report the condition of the antenna supply. Open circuit detection can also be supported with an additional external circuit. For details, please refer to the *ANTARIS System Integration Manual* [1].

Parameter	Specification	
Antenna Type	Active only	
Active Antenna Recommendations	Minimum gain	25 dB
	Maximum noise figure	1.5 dB
	Maximum gain	60 dB
Antenna Supply	Using VCC_RF or external	
Antenna Supervisor	Short circuit detection	Built-in
	Open circuit detection	Enabled with external circuit

Table 5: Antenna Specification

2 Performance Specification

Parameter	Specification			
Receiver Type	L1 frequency, C/A Code, 16-Channels 8192 search bins			
Max Update Rate	4 Hz			
Accuracy (Selective Availability off)	Position	2.5 m CEP ²	5.0 m SEP ³	
	Position DGPS / SBAS ¹	2.0 m CEP	3.0 m SEP	
Acquisition ⁴		Fast Acquisition Mode	Normal Mode	High Sensitivity Mode
	Cold Start ⁵	34 s	36 s	41 s
	Warm Start	33 s		
	Hot Start	<3.5 s		
Aided Start ⁶	5 s			
Signal Reacquisition	<1 s			
Sensitivity ⁷		Fast Acquisition Mode	Normal Mode	High Sensitivity Mode
	Acquisition	-134 dBm	-138 dBm	-140 dBm
Tracking	-143 dBm	-146 dBm	-149 dBm	
Timepulse Accuracy	RMS	50 ns		
	99%	<100 ns		
	Granularity	43 ns		
Dynamics	≤ 4 g			
Operational Limits	COCOM restrictions			

Table 6: Performance Specification

¹ Depends on accuracy of correction data of DGPS or SBAS service

² CEP = Circular Error Probability: The radius of a horizontal circle, centered at the antenna's true position, containing 50% of the fixes.

³ SEP = Spherical Error Probability. The radius of the sphere, centered at the true position, contains 50% of the fixes.

⁴ The different start-up modes like cold, warm and hot start are described in the System Integration Manual [1]

⁵ Measured with good visibility and -125 dBm signal strength

⁶ Time synch. signal from aiding source must be supplied to **EXTINT0** pin, having accuracy of better than 200 µs

⁷ Demonstrated with a good active antenna

3 Mechanical Specification

3.1 Dimensions

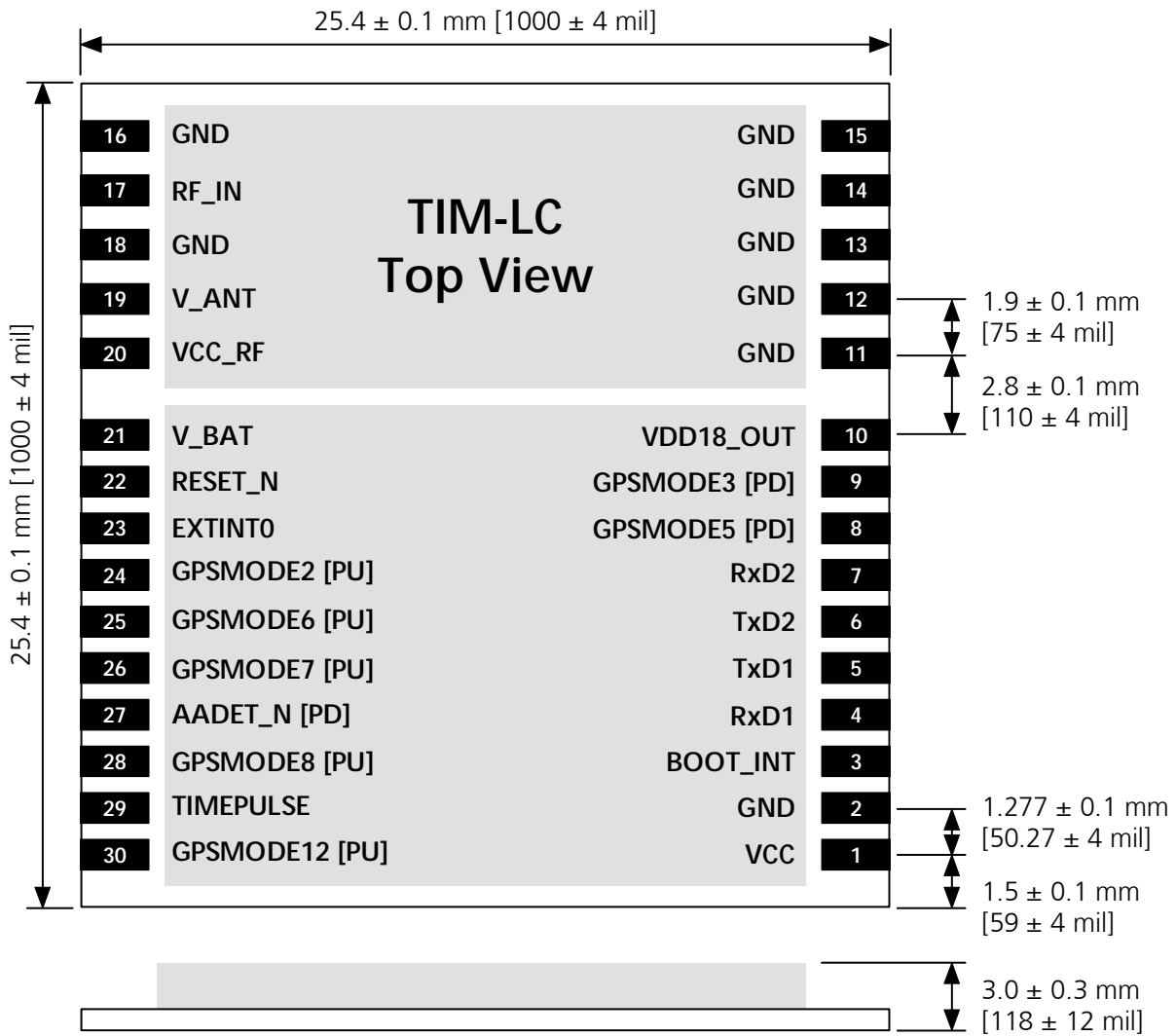

Figure 2: TIM-LC Dimensions

3.2 Specification

Parameter	Specification	Tolerance	Unit
Length	25.4	± 0.1	mm
Width	25.4	± 0.1	mm
Thickness	3.0	± 0.3	mm
Pitch RF pins	1.9	± 0.1	mm
Pitch Digital pins	1.277	± 0.1	mm
Weight	3		g

Table 7: Mechanical Specification

3.3 Pinout

Standard Function				Remarks
Pin	Name	I/O	Description	
1	VCC	I	Supply voltage	
2	GND	I	Ground	
3	BOOT_INT	I	Boot mode	Leave open if not used (normal operation)
4	RxD1	I	Serial Port 1	Pull up if not used
5	TxD1	O	Serial Port 1	Leave open if not used
6	TxD2	O	Serial Port 2	Leave open if not used
7	RxD2	I	Serial Port 2	Pull up if not used
8	GPSMODE5	I	Boot time configuration pin	Internal pull-down, leave open if not used
9	GPSMODE3	I	Boot time configuration pin	Internal pull-down, leave open if not used
10	VDD18_Out	O	1.8V supply output	Suitable for setting GPSMODE pins high Suitable as reference for external level shifter
11 - 16	GND	I	Ground	
17	RF_IN	I	GPS signal input	Apply no DC through this pin
18	GND	I	Ground	
19	V_ANT	I	Antenna Bias voltage	Connect to GND if not used
20	VCC_RF	O	Output Voltage RF section	May be connected to V_ANT
21	V_BAT	I	Backup voltage supply	Connect to GND if not used
22	RESET_N	I/O	Reset (Active low)	Concerning use of RESET_N signal, please refer to the ANTARIS System Integration Manual [1]
23	EXTINT0	I	External Interrupt Pin	Internal pull-up, leave open if not used
24	GPSMODE2	I	Boot time configuration pin	Internal pull-up, leave open if not used
25	GPSMODE6	I	Boot time configuration pin	Internal pull-up, leave open if not used
26	GPSMODE7	I	Boot time configuration pin	Internal pull-up, leave open if not used
27	AADET_N	I	Active Antenna Detect	Internal pull-down, leave open if not used
28	GPSMODE8	I	Boot time configuration pin	Internal pull-up, leave open if not used
29	TIMEPULSE	O	Timepulse signal	Leave open if not used
30	GPSMODE12	I	Boot time configuration pin	Internal pull-up, leave open if not used

Shaded pins operate with 1.8V signal levels

Table 8: Signals and Module Interface

4 Electrical Specification

4.1 Absolute Maximum Ratings

Parameter	Symbol	Min	Max	Units
Power Supply (VCC and V_BAT)				
Power supply voltage	Vcc	-0.3	3.6	V
Input Pins				
Input pin voltage (1.8V inputs, RESET_N)	Vio	-0.3	1.95	V
Input pin voltage (Rx/D1)	Vrx/d	-0.3	8	V
BOOT_INT pin	Vboot	-0.3	3.3	V
Voltage Supply output for Active Antenna and RF Section				
VCC_RF output current	Iccrf		50	mA
RF Input				
Antenna bias voltage (applied via V_ANT)	Vant	0	8	V
Antenna bias current (applied via V_ANT)	Iant		100	mA
Input power at RF_IN (source impedance 50Ω, continuous wave)	Prfin		0	dBm
Input power at RF_IN (824-829 MHz, 890-915 MHz, 1710-1785 MHz)	Prfin		10	dBm
Environment				
Storage temperature	Tstg	-40	125	°C

Table 9: Absolute Maximum Ratings

! Warning Stressing the device beyond the “Absolute Maximum Ratings” may cause permanent damage. These are stress ratings only. The product is not protected against overvoltage or reversed voltages. If necessary, voltage spikes exceeding the power supply voltage specification, given in table above, must be limited to values within the specified boundaries by using appropriate protection diodes.

4.2 Operating Conditions

Parameter ⁸	Symbol	Condition	Min	Typ	Max	Units
Power Supply						
Power supply voltage	Vcc		2.7		3.3	V
Power supply voltage ripple	Vcc_PP				50	mV
Sustained supply current ⁹	Icc	Vcc = 3.0 V		47		mA
Peak supply current ¹⁰	Iccp	Vcc = 3.3 V			125	mA
Sleep mode current	Iccs	Vcc = 3.0 V		100		μA
Backup battery voltage	Vbat		1.95		3.6	V
Backup battery current	Ibat	Vbat = 3.3V		15	40 (prelim.)	μA
1.8V output voltage (VDD18_Out pin)	Vdd18out		1.65	1.8	1.95	V
1.8V output current (VDD18_Out pin)	Idd18out				20	mA

Table 10: Operating Conditions

⁸ All specification are at an ambient temperature of 25°C.

⁹ Average current drawn during Continuous Tracking Mode with 1 Hz update rate, using 6 satellites for tracking and navigation. Use this figure to determine required battery capacity

¹⁰ Peak current drawn during initial acquisition phase. Use this figure to dimension maximum current capability of power supply

Parameter ¹¹	Symbol	Condition	Min	Typ	Max	Units
1.8V Digital I/Os and RESET_N						
Input pin voltage range	Vin18		0V		Vdd18out	V
Input pin low voltage	Vin_low18				0.45	V
Input pin high voltage	Vin_high18		1.4			V
Input pin voltage range	Vout18		0V		Vdd18out	V
Output pin low voltage	Vout_low18	Iout < 0.3 mA (sink)			0.1	V
Output pin high voltage	Vout_high18	Iout < 0.3 mA (source)	1.55			V
Output pin current at low voltage	Iout_low18	Vout_low18 = 0.28 V			2	mA
Output pin current at high voltage	Iout_high18	Vout_high18 = 1.35 V			2	mA
Input leakage current	Iin_leak18				1	μA
TxD1, TxD2 Pins						
Output Pin voltage range	VoutT		0V		Vcc	V
Output pin low voltage	Vout_lowT	Iout < 100μA (sink)			0.1	V
	Vout_lowT	Iout < 16mA (sink)			0.4	V
Output pin high voltage	Vout_highT	Iout < 10μA (source)	Vcc - 0.2			V
	Vout_highT	Iout < 40μA (source)	Vcc - 0.5			V
Output pin current at low voltage	Iout_lowT	Vout_lowT = 0.24 V			4	mA
Output pin current at high voltage	Iout_highT	Vout_highT = Vcc-0.5 V			40	μA
RxD1, RxD2 Pins						
Input Pin voltage range	VinR		0		5.5	V
Input pin low voltage	Vin_lowR				0.4	V
Input pin high voltage	Vin_highR		1.5	Vcc		V
BOOT_INT Pin						
Input Pin voltage range	VinB		0		Vcc	V
Input pin low voltage	Vin_lowB				0.4	V
Input pin high voltage	Vin_highB		2.7	Vcc		V
RF input						
Input power	Prfin				-46	dBm
V_ANT antenna bias voltage (must connect to ground if not used)	Vant		1.8		8	V
Antenna bias voltage drop	Vant_drop	Iant=10mA			50	mV
VCC_RF voltage	Vccrf			Vcc - 0.1		V
Environment						
Operating temperature	Topr		-40		85	°C

Table 10: Operating Conditions (continued)

Operation beyond the "Operating Conditions" is not recommended and extended exposure beyond the "Operating Conditions" may affect device reliability.

¹¹ All specification are at an ambient temperature of 25°C.

5 Environmental Specification

Detailed description of the test series:

Test		Standard
Visual inspection		IPC-A-610 "Acceptability of electronic assemblies" I.T.R.I. Publication No. 700 IPC-SM-840B Class 2.
Thermal shock	-40°C...+125°C, 100 cycles	IEC 68-2-14
Function at various temperatures	-40°C/2 hours; RT/2 hours; +85°C/2 hours; function tests at stable temperature	IEC 68-2-1 and IEC 68-2-2
Lifespan test	+85°C/1000 hours, in function	IEC 68-2-2
Damp heat, cyclic	+25°C...+55°C; >90% rH	IEC 68-2-30
Vibration	10-500 Hz; 2 hours/axis; 5g	IEC 68-2-6
Shock	30g/11ms (half sine); 3 Shock/axis; no function	IEC 68-2-27
Metallographic investigations		IPC-QE-650

Note: This specification is preliminary and yet subject to confirmation.

Table 11: Environmental Specification

6 Product Lineup

6.1 Default Settings

Following default settings apply if the GPSPIN pins are left unconnected:

Interface	Settings
Serial Port 1 Output	9600 Baud, 8 bits, no parity bit, 1 stop bit Configured to transmit both NMEA and UBX protocols, but only following NMEA and no UBX messages have been activated at start-up: GGA, GLL, GSA, GSV, RMC, VTG, ZDA, TXT Additional messages can be activated with appropriate input messages or with GPSPIN pins.
Serial Port 1 Input	9600 Baud, 8 bits, no parity bit, 1 stop bit, Autobauding disabled Automatically accepts following protocols without need of explicit configuration: UBX, NMEA, RTCM The GPS receiver supports interleaved UBX and NMEA messages.
Serial Port 2 Output	38400 Baud, 8 bits, no parity bit, 1 stop bit Configured to transmit both NMEA and UBX protocols, but only following UBX and no NMEA messages have been activated at start-up: NAV-POSLH, NAV-SOL, NAV-SVINFO, NAV-STATUS, NAV-POSECEF, NAV-DOP, NAV-VELECEF, NAV-VELNED, NAV-TIMEGPS, NAV-TIMEUTC, NAV-CLOCK MON-IO, MON-SCHD, MON-IPC, INF-Warning, INF-Error, INF-Notice Additional messages can be activated with appropriate input messages.
Serial Port 2 Input	38400 Baud, 8 bits, no parity bit, 1 stop bit, Autobauding disabled Automatically accepts following protocols without need of explicit configuration: UBX, NMEA, RTCM The GPS receiver supports interleaved UBX and NMEA messages.
TIMEPULSE	1 pulse per second, synchronized at rising edge, pulse length 100ms

Table 12: Available Protocols

6.2 Ordering Information

Ordering No.	Product
TIM-LC-0-000-0	TIM-LC GPS Receiver Module <u>Delivery Packing</u> 0 = Single samples 1 = Tape on reel (100 pieces) 5 = Tape on reel (500 pieces)

Table 13: Ordering Information

Parts of this product are patent protected.