

Housing for the ECX-306X/306IX crystal is made from the same thermoplastic that is industry standard for integrated circuits. This ruggedized molded package is excellent for SMD applications.

## FEATURES

- Low profile
- Long term stability
- Industry standard footprint
- Excellent shock resistance
- Excellent environmental characteristics
- Tape and Reel (3,000 pcs)
- RoHS Compliant w/ Exemption for High Temp Solder



## PART NUMBERING GUIDE "EXAMPLE"

MANUFACTURER	FREQUENCY	LOAD CAPACITANCE	PACKAGE TYPE**
ECS	- .327	- 12.5	- 17X

\*\* Package Type examples (-17X= ECX-306,X 17X= ECX-306IX)

## OPERATING CONDITIONS/ELECTRICAL CHARACTERISTICS

PARAMETERS		ECX-306/306I	UNITS
NOMINAL FREQUENCY	F <sub>0</sub>	32.768	KHz
LOAD CAPACITANCE	C <sub>L</sub>	12.5 Standard (6.0 Optional)	pF
DRIVE LEVEL	D <sub>L</sub>	1 max.	μW
CALIBRATION TOLERANCE	@ 25°C	±20	PPM
EQUIVALENT SERIES RESISTANCE	R <sub>1</sub>	50 max.	KΩ
TEMPERATURE COEFFICIENT		-0.040 PPM/°C <sup>2</sup> max.	PPM/(ΔC°)
OPERATING TEMPERATURE RANGE	T <sub>OPR</sub>	-10 ~ +60	°C
MAX. OPERATING TEMPERATURE RANGE		-40 ~ +85	°C
Q FACTOR	Q	50,000 min.	
TURNOVER TEMPERATURE	T <sub>O</sub>	+25 ± 5	°C
STORAGE TEMPERATURE RANGE	T <sub>STG</sub>	-55 ~ +125	°C
INSULATION RESISTANCE	IR	500MΩ min./ DC 100V	MΩ
SHUNT CAPACITANCE	C <sub>0</sub>	1.35 typical	pF
MOTIONAL CAPACITANCE	C <sub>1</sub>	0.003 pF typical	pF
AGING (FIRST YEAR)	Δf/f <sub>0</sub>	±3 PPM max. @ +25°C	PPM

## PACKAGE DIMENSIONS (mm)

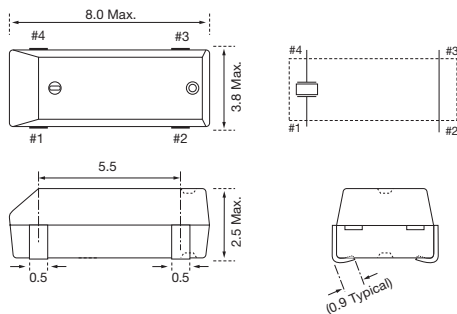

Figure 1) ECX-306 - Top, Side and End views with pin connections

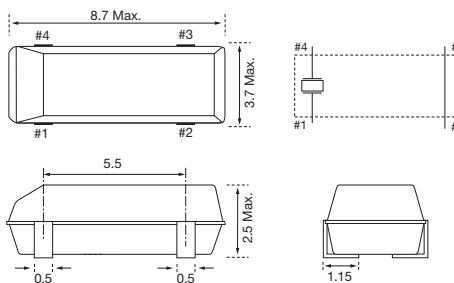

Figure 2) ECX-306I - Top, Side and End views with pin connections

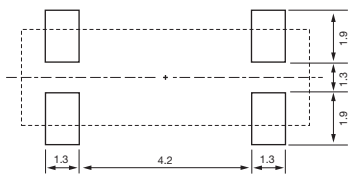
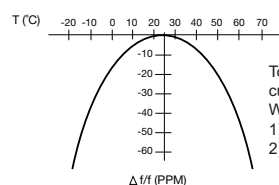

Figure 3) ECX-306/306I Land Pattern - Top view

## PARABOLIC TEMPERATURE CURVE



To determine frequency stability, use parabolic curvature. For example:  
 What is the stability at 45°C?  
 1) Change in T (°C) = 45 - 25 = 20°C  
 2) Change in frequency = -0.04 PPM × (ΔT)<sup>2</sup>  
 = -0.04 PPM × (20)<sup>2</sup>  
 = -16.0 PPM

## RECOMMENDED OSCILLATION CIRCUIT

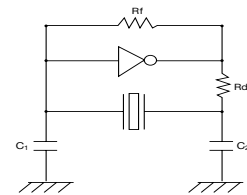

## ELECTRICAL CHARACTERISTICS

IC: TC 4069P  
 R<sub>f</sub>: 10MΩ  
 R<sub>d</sub>: 330KΩ (As required)  
 C<sub>1</sub> = 22pF, C<sub>2</sub> = 22pF  
 V<sub>DD</sub> = 3.0V

In this circuit, low drive level with a maximum of 1μW is recommended. If excessive drive is applied, irregular oscillation or quartz element fractures may occur.