



Sparkle Power Inc.
 A Leading Power Supply Manufacturer
 Web site: www.sparklepower.com

FSP300-60GLS **(RoHS Compliant)**

300 Watts SFX12V Switching Power Supply

Features

- Complied with SFX12V standard
- Active Power Factor Correction (PFC) meet EN61000-3-2
- High efficiency and reliability
- Compatible with European Union Directive 2002/95/EC (Restriction on Hazardous Substances).
- Remote ON/OFF function
- Internal 12V DC fan included
- Noise Killer (thermal fan speed control function)
- Low noise and ripple
- Output over voltage, short circuit, and over current protection
- 100% Hi-pot, ATE, and burn-in tested
- Re-settable power shut down
- Complies with FCC part 15 subpart J class B 115Vac operation, and CISPR 22 class B at 230Vac operation
- Approved by CUL/UL60950-1, CSA C22.2 NO. 60950-1, FIMKO EN60950-1, SEMKO EN60950-1, NEMKO EN60950-1 (CB Renort) CE

Input Characteristics

Input Range: 90 ~ 265Vac (RMS), Full Range Input
Frequency: 47 ~ 63Hz
Input Current: Max 4A (RMS) @ 115Vac, 2A (RMS) @ 230Vac
Inrush Current: No damage

Output Characteristics

Output Voltage	Minimum Load	Normal Load	Maximum Load	Load Reg.	Ripple & Noise
+3.3V	0.5A	10A	20A	± 5%	50mV P-P
+5V	0.3A	9A	18A	± 5%	50mV P-P
+12V1	1.0A	4A	8A	± 5%	120mV P-P
+12V2	1.0A	8A	16A	± 5%	120mV P-P
-12V	0.0A	0.25A	0.5A	± 10%	120mV P-P
+5Vsb	0.0A	1.0A	2.0A	± 5%	50mV P-P

*+3.3V and +5V total output not exceed 125W

* Total output for this subject power supply is 300W



Specification

- **Temperature Range:** Operating: 0°C ~ +50°C ; storage & shipping: -20°C ~ +80°C
- **Humidity:** 5 ~ 95% on operating, 5 ~ 95% on storage
- **Dielectric Withstand:** Primary frame ground 1800V AC for 1 second
- **Efficiency:** 70% minimum
- **Rise time:** Less than 20ms
- **Hold-up Time:** 17ms minimum at nominal input voltage
- **Power Good Signal:** Power on delay time 100 ~ 500ms, off delay 1ms minimum (TTL and CMOS compatible)
- **Leakage Current:** Less than 3.5mA .
- **MTBF:** 100,000 hours on maximum load at +25°C
- **Dimensions (LxWxH):** 100x125x63.5mm / 4x4.9x2.5inch

Sparkle Power Inc.
Main Office
 1000 Rock Avenue
 San Jose, CA 95131
 TEL: 408-519-8888
 FAX: 408-519-9999
 E-MAIL: info@sparklepower.com

Sparkle Power Inc.
Los Angeles Office
 17071 Green Drive
 City of Industry, CA 91745
 TEL: 626-839-7180
 FAX: 626-839-3395

REF. ID.	PIN NO.	SIGNAL	WIRE COLOR	GAUGE	CONNECTOR TYPE	CABLE LENGTH
P1	1	+3.3VDC	ORANGE	18	C4202HD2-A4P+, C4202HD2-A20P+ or EQUIV.	300±15mm
	2	+3.3VDC	ORANGE	18		
	3	COM	BLACK	18		
	4	+5VDC	RED	18		
	5	COM	BLACK	18		
	6	+5VDC	RED	18		
	7	COM	BLACK	18		
	8	PW-OK	GRAY	24		
	9	+5Vsb	PURPLE	20		
	10	+12V1	YELLOW	18		
	11	+12V1	YELLOW	18		
	12	+3.3VDC	ORANGE	18		
	13	+3.3VDC +3.3V _{Sense}	ORANGE BROWN	18 24		
	14	-12VDC	BLUE	24		
	15	COM	BLACK	18		
	16	PS-ON	GREEN	24		
	17	COM	BLACK	18		
	18	COM	BLACK	18		
	19	COM	BLACK	18		
	20					
PA	1	+3.3V	ORANGE	18	MOLEX CL1271HS0 15P or EQUIV.	300±15mm
	2	COM	BLACK	18		
	3	+5V	RED	18		
	4	COM	BLACK	18		
PB	1	+3.3V	ORANGE	18	MOLEX CL1270H00 15P or EQUIV.	170±10mm
	2	COM	BLACK	18		
	3	+5V	RED	18		
	4	COM	BLACK	18		
P2	1	COM	BLACK	18	MOLEX 39-01-2040 or EQUIV.	300±15mm
	2	COM	BLACK	18		
	3	+12V2	YEL/BLK	18		
	4	+12V2	YEL/BLK	18		
P3 P5	1	+12V1	YELLOW	18	MOLEX 1-480424-0 or EQUIV.	300±15mm
	2	COM	BLACK	18		
	3	COM	BLACK	18		
	4	+5V	RED	18		
P4	1	+12V1	YELLOW	18	MOLEX 1-480424-0 or EQUIV.	170±10mm
	2	COM	BLACK	18		
	3	COM	BLACK	18		
	4	+5V	RED	18		
P6	1	+5V	RED	20	MOLEX 171822-4 or EQUIV.	170±10mm
	2	COM	BLACK	20		
	3	COM	BLACK	20		
	4	+12V1	YELLOW	20		

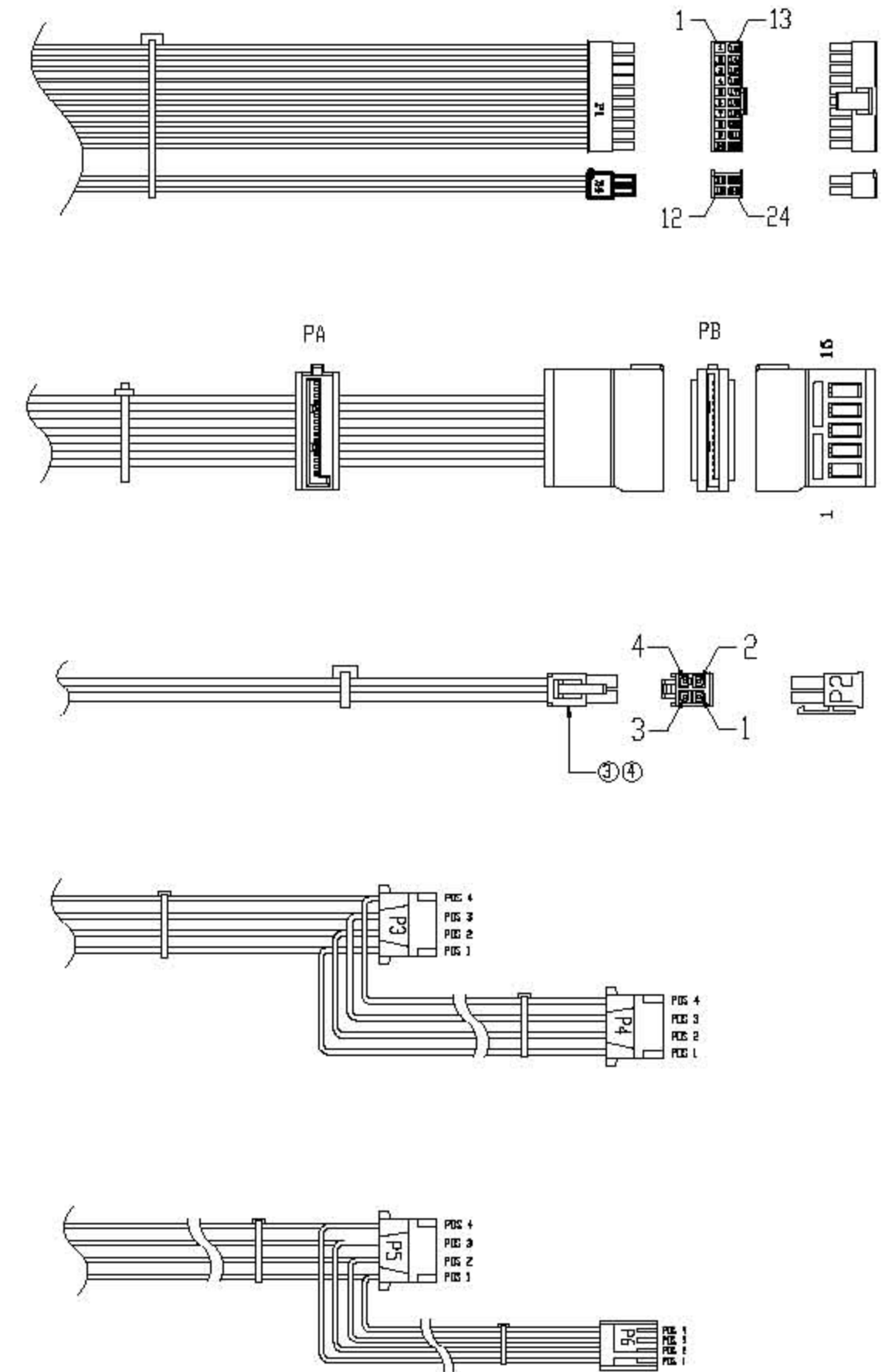
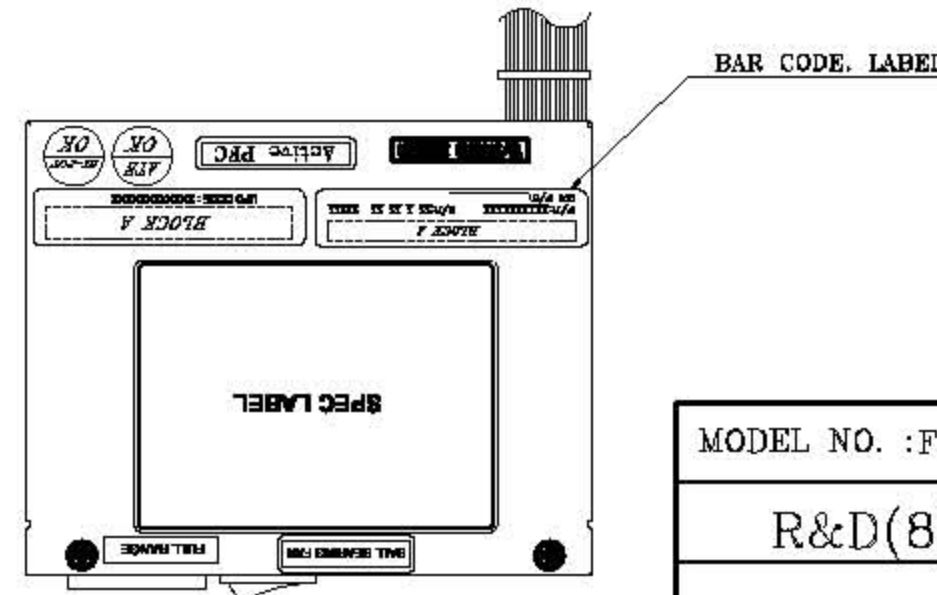
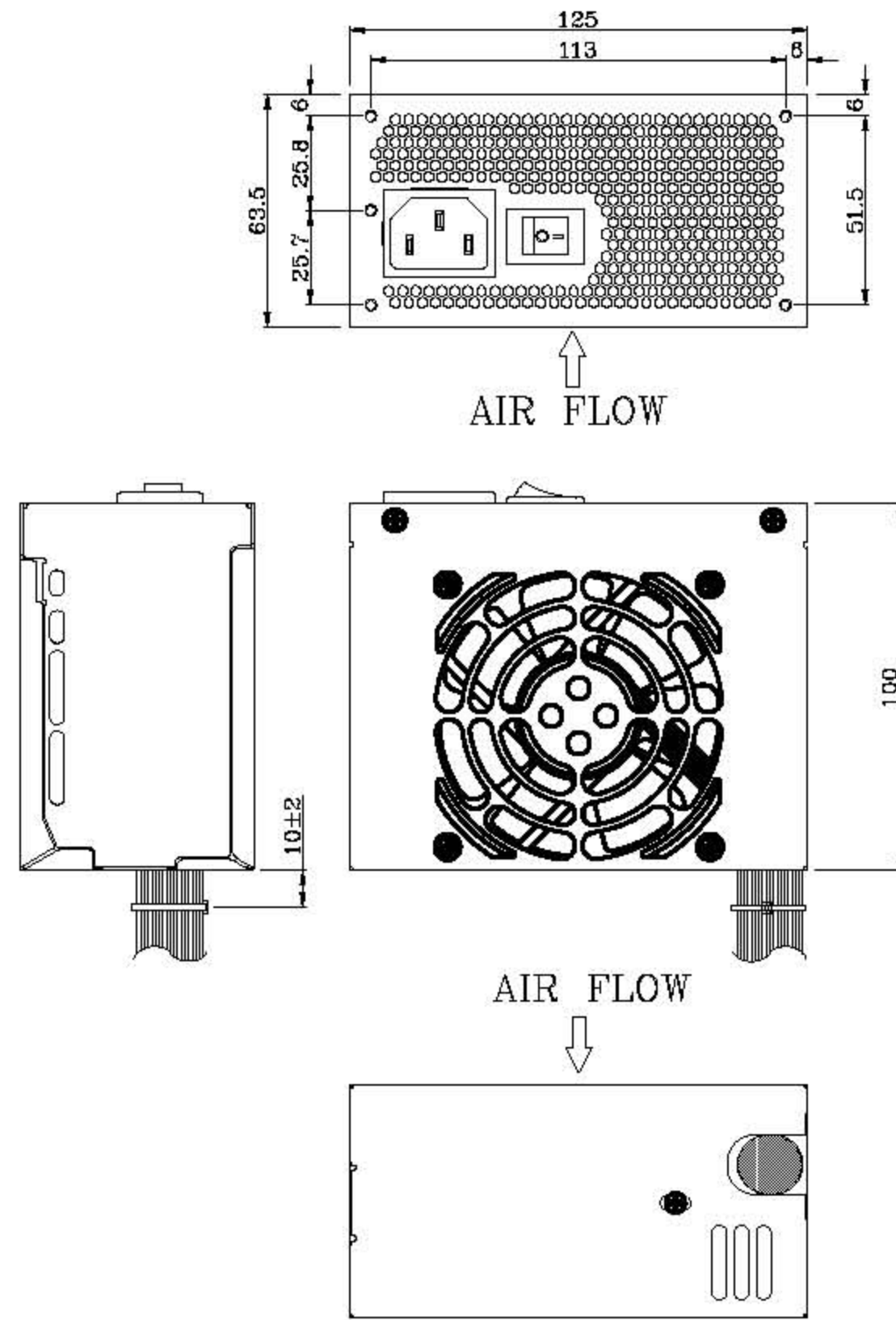

NOTE:

1. ALL THE LENGTH OF OUTPUT WIRES EXCLUDE HOUSING.
2. 產地標籤依業務指示加貼.

UNIT:mm

SPI/PN:FSP300GLS-B204
P/N.:9PA300A332

MODEL NO. :FSP300-60GLS(S03001)		TITLE: ASSY		SHEET: 1 OF 1		REV:01
R&D(8)	PE	CHECKED	DESIGN	DRAWN	DATE	
					MAR.05.2007	
INTERIOR COUNTERSIGN:						<i>J. J. J.</i>