

To all our customers

Regarding the change of names mentioned in the document, such as Mitsubishi Electric and Mitsubishi XX, to Renesas Technology Corp.

The semiconductor operations of Hitachi and Mitsubishi Electric were transferred to Renesas Technology Corporation on April 1st 2003. These operations include microcomputer, logic, analog and discrete devices, and memory chips other than DRAMs (flash memory, SRAMs etc.) Accordingly, although Mitsubishi Electric, Mitsubishi Electric Corporation, Mitsubishi Semiconductors, and other Mitsubishi brand names are mentioned in the document, these names have in fact all been changed to Renesas Technology Corp. Thank you for your understanding. Except for our corporate trademark, logo and corporate statement, no changes whatsoever have been made to the contents of the document, and these changes do not constitute any alteration to the contents of the document itself.

Note : Mitsubishi Electric will continue the business operations of high frequency & optical devices and power devices.

Renesas Technology Corp.
Customer Support Dept.
April 1, 2003

M5290P,FP

±5V TRACKING REGULATOR WITH RESET CIRCUIT

DESCRIPTION

M5290 is a semiconductor integrated circuit designed for voltage regulator which is dual tracking type (positive/negative output voltage) with system reset circuit.

Since the output voltage is fixed inside, User can omit the outside resistors, and this IC includes the system reset circuit for detecting the abnormal status of Power Supply. When Power Supply of system is in abnormal status, this IC sends the system reset output (Low) to the MPU/CPU, so User can make the system operate safely.

FEATURES

- High input voltage..... $V_I = \pm 20V$
- Fixed output voltage..... $V_O = \pm 5V$
- Internal system reset circuit (with hysteresis) detectable voltage.....4.2V (deray time is variable by connecting capacity at 7pin (6pin for the FP))
- Current limiting circuit, thermal protection circuit
- Capable of ON/OFF control (10pin)
- Very Low input-output voltage differential operation by using transistor
- Variable output voltage (with external resistors connected between terminals ① and GND and between positive output terminals).

APPLICATION

Dual power supply for CD players and stereo set pre-/main-amplifiers

PIN CONFIGURATION (TOP VIEW)

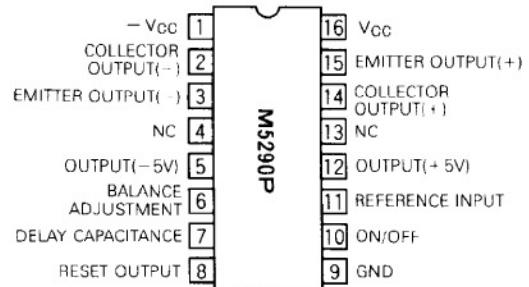

Outline 16P4

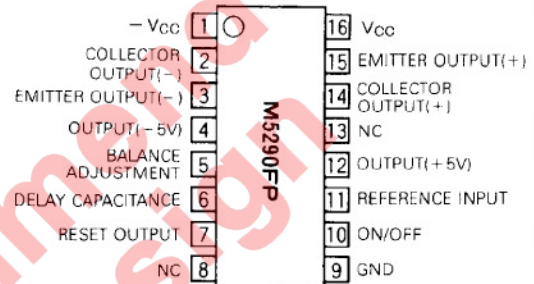

Outline 16P2S-A

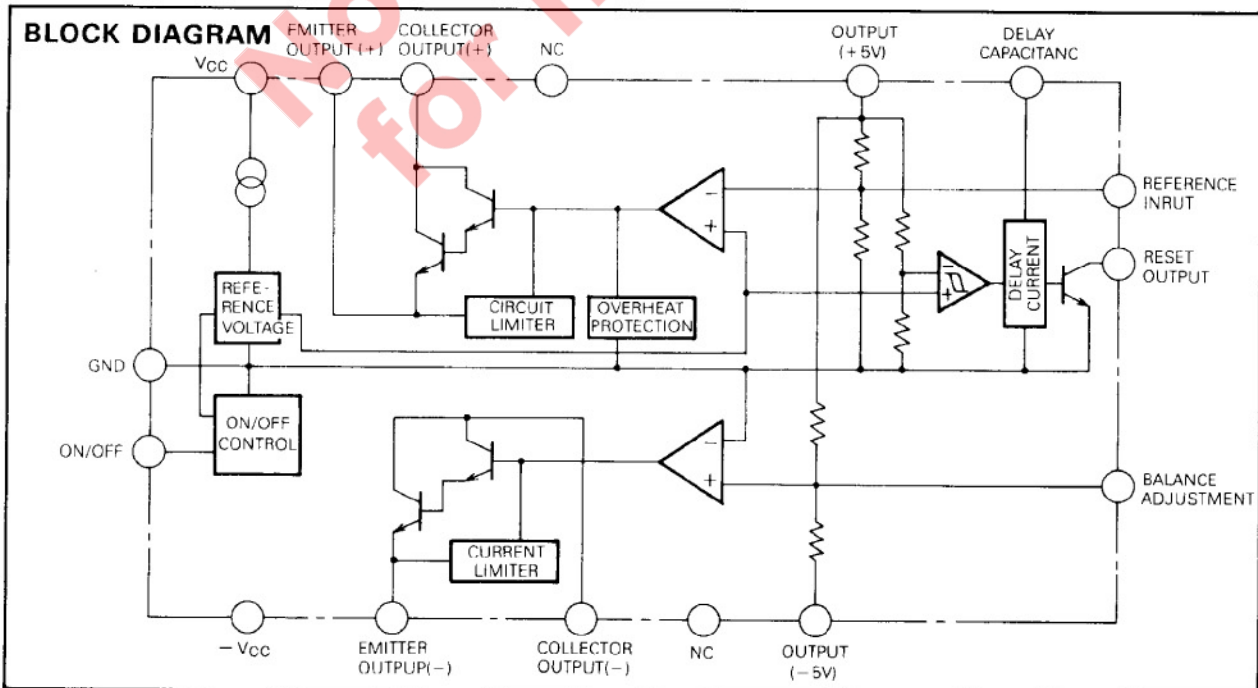

±5V TRACKING REGULATOR WITH RESET CIRCUIT**ABSOLUTE MAXIMUM RATINGS** ($T_a = 25^\circ\text{C}$, unless otherwise noted)

Symbol	Parameter	Conditions	Ratings	Unit
V_{CC}	Supply voltage		± 20 (40)	V
I_{LP}	Load current		± 30	mA
V_{DIF}	Input/Output Voltage difference		± 15 (30)	V
P_d	Power dissipation		1.0(P)/0.55(FP)	W
K_θ	Thermal derating	$T_a \geq 25^\circ\text{C}$	10.0(P)/5.5(FP)	mW/°C
T_{opr}	Ambient temperature		$-20 \sim +75$	°C
T_{stg}	Storage temperature		$-55 \sim +125$	°C

ELECTRICAL CHARACTERISTICS ($T_a = 25^\circ\text{C}$, $V_{CC} = \pm 8\text{V}$, $I_L = \pm 10\text{mA}$, unless otherwise noted)

Symbol	Parameter	Test condition	Limits			Unit
			MIN	TYP	MAX	
I_{CC}	Circuit current		—	3.0	6.0	mA

REGULATOR PART

Symbol	Parameter	Test conditions	Limits			Unit
			MIN	TYP	MAX	
V_{IN}	Input voltage		$\pm V_O \pm 2$	—	± 20	V
V_O	Output voltage		± 4.75	± 5.0	± 5.25	V
V_{REF}	Reference input voltage		1.15	1.20	1.25	V
ΔV_O	Dual voltage tracking		—	0.5	2	%
R.R	Ripple rejection	$C_{REF} = 1\mu\text{F}$, $f = 120\text{Hz}$	50	65	—	dB
REG-in	Input voltage rejection	$V_I = \pm 8 \sim \pm 18\text{V}$	—	0.05	0.2	%/V
REG-IO	Loading voltage rejection	$I_{L0} = 0 \sim 20\text{mA}$	—	20	100	mV
V_{NO}	Output noise voltage	$f = 20\text{Hz} \sim 100\text{kHz}$	—	10	—	μV_{rms}
$V_{O(off)}$	Output cut-off voltage	10pin GND	—	—	± 0.1	V

RESET PART

Symbol	Parameter	Test conditions	Limits			Unit
			MIN	TYP	MAX	
V_S	Detected voltage		3.95	4.2	4.45	V
ΔV_S	Hysteresis voltage		50	100	300	mV
T_{pd}	Delay time	$C_d = 0.1\mu\text{F}$	3	7	14	mS
V_{sat}	Output saturation voltage	$I_{sink} = 3\text{mA}$	—	0.2	0.4	V

Note: The employed measurement circuit conforms to application circuit example (1).

±5V TRACKING REGULATOR WITH RESET CIRCUIT

APPLICATION EXAMPLE

1. Standard application example ($I_L = \pm 30\text{mA}$)

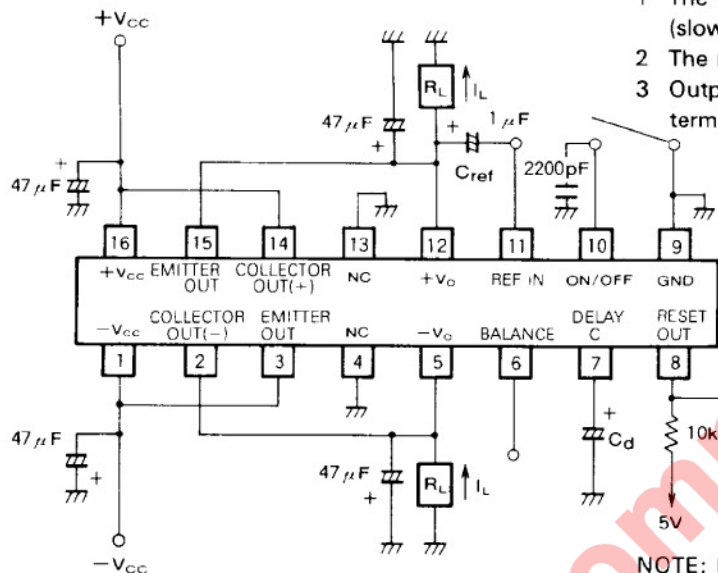

CREF

Connection of this capacitor gives the following characteristics.

- 1 The rise time of the output voltage can be adjusted (slowed).
- 2 The ripple rejection ratio is improved.
- 3 Output noise voltage is reduced down to 1/10 of three terminal regulator IC.

TO BE CONNECTED TO A MICROCOMPUTER OR OTHER RESET TERMINAL

The output is cut off when 10pin is connected to the GND terminal.

NOTE: Ensure that the capacitance of the employed capacitor does not significantly vary with the temperature.

2. Very Low input-out voltage differential operation

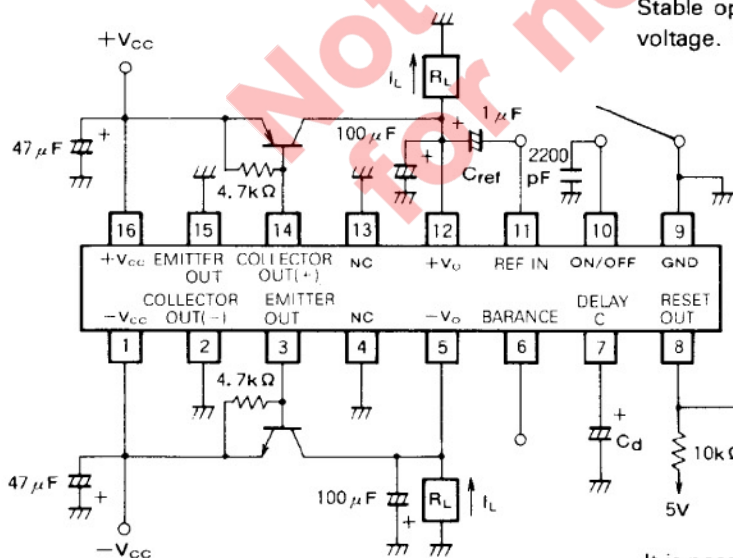

Stable operations are expected even if the input-output voltage. Differences are quite low as 0.2V.

TO BE CONNECTED TO A MICROCOMPUTER OR OTHER RESET TERMINAL

It is possible to drive 1A by connecting Power Transistor. By shorting the 10pin to the GND, the output is shut down.

±5V TRACKING REGULATOR WITH RESET CIRCUIT

**(3) Foldback Protection Circuit Application
Example (M5290P Foldback System)**

The input/output voltage differential V_{IO} should be adjusted to be high enough considering the voltage difference developed at R_1 .

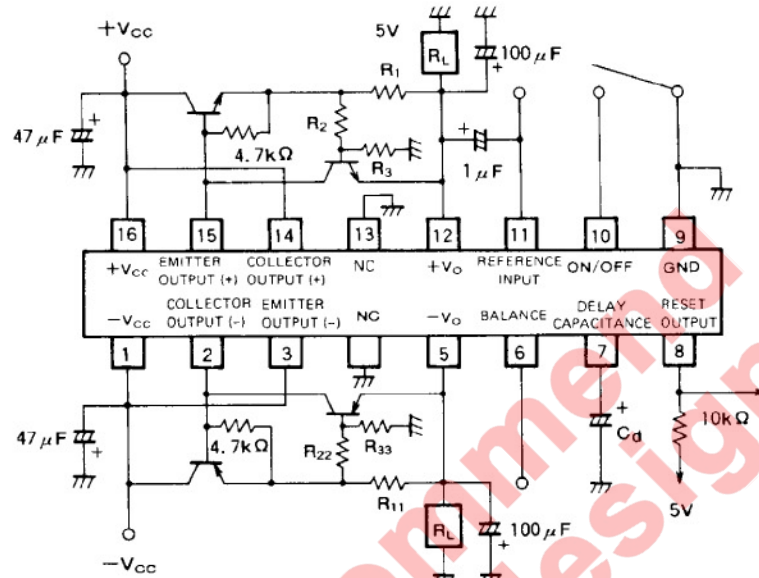

When two protective transistors are employed, the M5290P/FP can provide foldback characteristic for protection purposes. The I_1 and I_2 values are determined according to the external resistance.

$$I_1 \doteq \frac{R_2 + R_3}{R_1 \cdot R_3} \times 0.65 \text{ (A)}$$

$$I_2 \doteq I_1 + \frac{R_2}{R_1 \cdot R_3} \times 12 \text{ (A)}$$

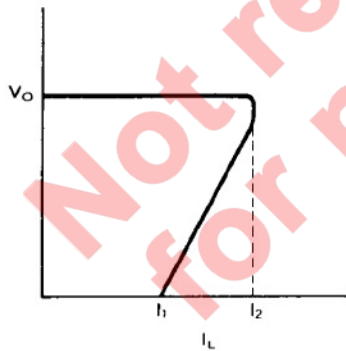

Cases where $I_{L(PEAK)} = I_2 \approx 500\text{mA}$ and $I_1 \approx 100\text{mA}$

$R_1 = R_{11} = 13\ \Omega$, $R_2 = R_{22} = 2\text{k}\ \Omega$, $R_3 = R_{33} = 2\text{k}\ \Omega$

The required input/output voltage differential is 8V or greater.

±5V TRACKING REGULATOR WITH RESET CIRCUIT

ATTENTION

1. In adjusting the output voltage (use ⑪ pin)

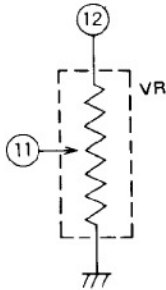

M5290P, FP is fixed the output voltage by inside resistors, but user can adjust it by using the outside resistor.
(inside resistor: 2.4kΩ ⑪ to ⑨, 7.6kΩ ⑫ to ⑪)

2. In adjusting the tracking voltage (use ⑥ pin (⑤ pin on FP))

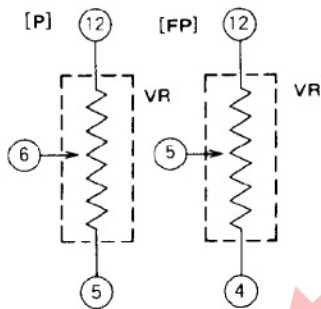

M5290P, FP is fixed the tracking voltage by inside resistor, but user can adjust it by using the output resistor.
(inside resistor: ⑫ to ⑥ ⑥ to ⑤, 10kΩ for the M5290P)
: ⑫ to ⑤ ⑤ to ④, 10kΩ for the M5290FP)

3. Explaining figure of reset operation

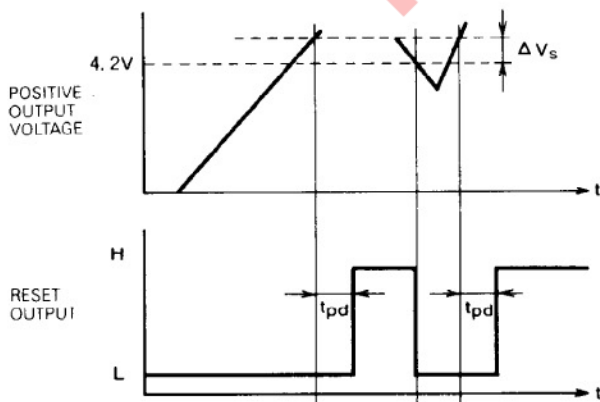

When the positive output voltage is normal, the Reset output is High.
If it is lower than 4.2V, the Reset output is low.
(delay time is variable by connecting capacity at 7pin (6pin for the FP))

$$t_{pd} = 7.0 \times 10^4 \times C \text{ (sec)}$$

C: delay time capacity