



M I C R O T U N E ®

RF SILICON AND SUBSYSTEMS SOLUTIONS
FOR BROADBAND COMMUNICATIONS AND AUTOMOTIVE ELECTRONICS

MICROTUNER™ MT2011 SINGLE-CHIP BROADBAND TUNER

PRODUCT BRIEF

The MicroTuner MT2011 is a fully integrated single-chip tuner, optimized for digital OpenCable compliant STB applications.



MT2011 Single-Chip Broadband Tuner

The MicroTuner™ MT2011 is a fully integrated single-chip tuner, with functional blocks specifically designed to ease implementation of high-performance digital OpenCable™ set-top boxes.

The MT2011 is a dual-conversion tuner design which requires no external tracking filters. This eliminates the need for manual alignments and simplifies its deployment on the production line where consistent high quality and reliability are key factors. The device maintains its controlled impedance across the entire input spectrum and exhibits good selectivity and sensitivity and low in-band emissions. Its low phase noise makes it an excellent choice for digital set top box applications.

The high level of circuit block integration in the MT2011 reduces the number of external components required for a fully functional design, thereby lowering the overall solution cost. It includes a low noise amplifier (LNA) in the front, a Forward Data Channel (FDC) amplifier and an intermediate frequency (IF) buffer amplifier at the back-end. An on-chip System Reference Oscillator (SRO) output with selectable sub-multiples of 1, 2, or 4 can drive an additional tuner or IC in a multi-tuner application. A high first IF followed by an image-reject mixer gives the MT2011 unparalleled performance over its entire operating range from 48 MHz to 1 GHz.

All functions of the MT2011 are controlled over a two-wire serial bus. This includes the ability to readback the status registers of the tuner as well as the on-board die temperature sensor.

APPLICATIONS

- Advanced digital set-top boxes (STB)
- Home gateways
- Cable modems
- HDTV

FEATURES

- 1 GHz bandwidth
- Excellent linearity performance in severely sloped input conditions per SCTE 40 network requirements
- Ease of multi-tuner front-end implementations
- Dual-conversion architecture for consistent high performance with no manual alignments
- Proven performance in dual-function digital STB designs
- Elimination of the need for the 28V to 33V supplies typically required by traditional tuners
- 3.3V and 5V serial bus compatible
- Minimal external components
- Software shutdown mode
- Intermediate frequency (IF) output fully compatible with demodulators for DAVIC, DVB-C, DOCSIS®, EuroDOCSIS™, and other standards
- Small 8mm x 8mm 56-lead QFN package
- Usable in conjunction with Microtune's upstream amplifiers to create a complete RF front end for bi-directional STB applications

PRELIMINARY

M I C R O T U N E

RECOMMENDED OPERATING CONDITIONS

PARAMETER	MIN	TYP	MAX	UNIT
Input frequency range	48		1000	MHz
Second intermediate center frequency (programmable)	30		57	MHz
Supply voltage, +3.3 V	3.15	3.3	3.45	V
Supply voltage, +5 V	4.75	5.0	5.25	V
Supply voltage ripple			15	mVp-p
Operating junction temperature			125	°C
VGA differential output load impedance	300			Ω
Serial control clock			400	kHz
DNC differential load impedance	800			Ω

ABSOLUTE MAXIMUM RATINGS

PARAMETER	MIN	MAX	UNIT
Supply voltage, +3.3 V		3.6	V
Supply voltage, +5 V		6	V
Storage temperature range	-50	+150	°C
Lead Free solder temperature (5 seconds, 3 reps.)		+260	°C

TUNER ELECTRICAL CHARACTERISTICS

PARAMETER	MIN	TYP	MAX	UNIT
Power Supply				
Active current, 3.3 V		82		mA
Active current, 5 V		270		mA
RF Signal Path				
Input frequency range	48		1000	MHz
Noise figure (DNC Out)			10.5	dB
Terminal voltage gain (DNC Out)		39		dB
RF AGC range (0 to 3.3 V) ¹		30		dB
Image rejection		75		dBc
LO phase noise (1 kHz)		-75		dBc/Hz
LO phase noise (10 kHz)		-85		dBc/Hz
LO phase noise (100 kHz) 48 MHz to 860 MHz		-105		dBc/Hz
LO phase noise (100 kHz) 860 MHz to 1000 MHz		-104		dBc/Hz
LO step size	2			kHz
IF VGA				
Frequency range	30		57	MHz
Output voltage swing		1.0		Vp-p
Terminal voltage gain, VGACTRL = 0.7 to 3.3 V	<12.5		>51.5	dB
IF AGC range		39		Db
FDC				
Frequency Range	70		130	MHz
Gain		1		dB
Noise Figure		12		dB

¹Note: With Microtune attenuator design

PRELIMINARY

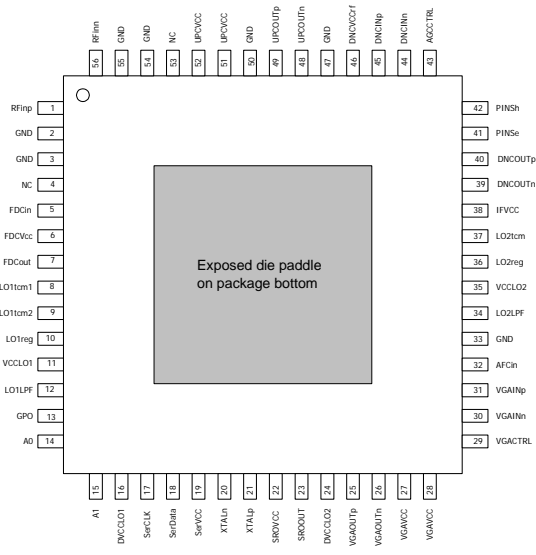

MT2011 Pin Diagram

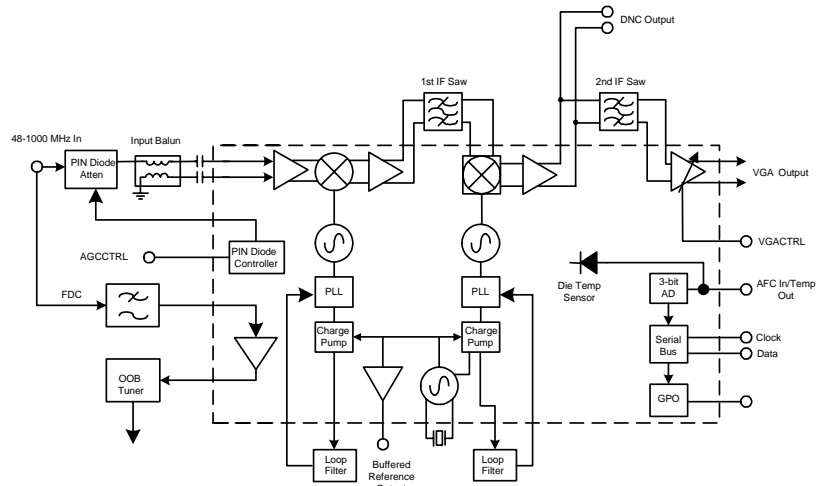

MT2011 Block Diagram



Microtune, Inc., 2201 10th Street, Plano, TX 75074, USA

Tel: +1-972-673-1600, Fax: +1-972-673-1602, E-mail: sales@microtune.com, Web site: www.microtune.com

For a detailed list of office locations, sales offices, and sales representatives, visit our web site at www.microtune.com

Microtune believes that the information in this document is accurate and reliable, as of the date of this document. Microtune assumes no responsibility for any consequences arising from the use of this information, nor from any infringement of patents or the rights of third parties which may result from its use. No license is granted by implication or otherwise under any patent or other rights of Microtune. The information in this publication replaces and supersedes all information previously supplied, and is subject to change without notice. The customer is responsible for assuring that proper design and operating safeguards are observed to minimize inherent and procedural hazards. Microtune assumes no responsibility for applications assistance or customer product design.

The devices described in this document are not authorized for use in medical, life-support equipment, or any other application involving a potential risk of severe property or environmental damage, personal injury, or death without prior express written approval of Microtune. Any such use is understood to be entirely at the user's risk.

Microtune is a registered trademark of Microtune, Inc. MicroTuner, MicroStreamer, VideoCaster, DataCaster, ClearTune, and the Microtune logo are trademarks of Microtune, Inc. All other trademarks belong to their respective companies.

Microtune's products are protected by one or more of the following U.S. patents: 5,625,325; 5,648,744; 5,717,730; 5,737,035; 5,739,730; 5,805,988; 5,847,612; 6,100,761; 6,104,242; 6,163,684; 6,169,569; 6,172,378; 6,177,964; 6,211,745; 6,218,899; 6,268,778; 6,310,387; 6,323,736; 6,355,537; 6,429,502; 6,462,327; 6,535,068; 6,580,313; 6,608,522; 6,631,257; 6,714,776; 6,725,463; 6,744,308; 6,771,124; 6,784,945; 6,804,099; 6,888,406; 6,891,435; 6,906,594; 6,909,886; 6,919,774; 6,920,182; 6,922,556; 6,963,478; 6,973,288; 6,993,310; 7,035,614; 7,078,960; 7,079,195; 7,164,899; 7,171,176; 7,184,724; 7,190,942; 7,190,943; D469,742 and additional patents pending or filed.