

Silicon PNP Power Transistors

2SB828

DESCRIPTION

- With TO-3PN package
- Complement to type 2SD1064
- Low collector saturation voltage
- Wide area of safe operation

APPLICATIONS

- Relay drivers,high-speed inverters, converters,and other general high-current switching applications

PINNING

PIN	DESCRIPTION
1	Base
2	Collector;connected to mounting base
3	Emitter

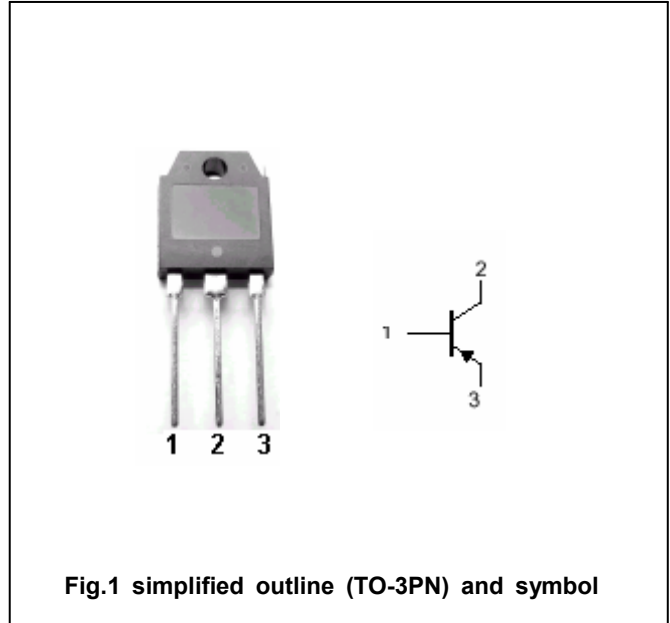
**Absolute maximum ratings($T_c=25^\circ\text{C}$)**

SYMBOL	PARAMETER	CONDITIONS	VALUE	UNIT
V_{CBO}	Collector-base voltage	Open emitter	-60	V
V_{CEO}	Collector-emitter voltage	Open base	-50	V
V_{EBO}	Emitter-base voltage	Open collector	-6	V
I_C	Collector current		-12	A
I_{CM}	Collector current-peak		-17	A
P_C	Collector power dissipation	$T_c=25^\circ\text{C}$	80	W
T_j	Junction temperature		150	$^\circ\text{C}$
T_{stg}	Storage temperature		-55~150	$^\circ\text{C}$

Silicon PNP Power Transistors

2SB828

CHARACTERISTICS

T_j=25°C unless otherwise specified

SYMBOL	PARAMETER	CONDITIONS	MIN	TYP.	MAX	UNIT
V _{(BR)CEO}	Collector-emitter breakdown voltage	I _C =-1mA ; R _{BE} =∞	-50			V
V _{(BR)CBO}	Collector-base breakdown voltage	I _C =-1mA ; I _E =0	-60			V
V _{(BR)EBO}	Emitter-base breakdown voltage	I _E =-1mA ; I _C =0	-6			V
V _{CEsat}	Collector-emitter saturation voltage	I _C =-6A ; I _B =-0.3A			-0.5	V
I _{CBO}	Collector cut-off current	V _{CB} =-40V ; I _E =0			-0.1	mA
I _{EBO}	Emitter cut-off current	V _{EB} =-4V ; I _C =0			-0.1	mA
h _{FE-1}	DC current gain	I _C =-1A ; V _{CE} =-2V	70		280	
h _{FE-2}	DC current gain	I _C =-5A ; V _{CE} =-2V	30			
f _T	Transition frequency	I _C =-1A ; V _{CE} =-5V		10		MHz

Switching times

t _{on}	Turn-on time	I _C =-5.0A ; I _{B1} =-I _{B2} =-0.5A R _L =4Ω ; V _{CC} =-20V		0.2		μs
t _{stg}	Storage time			0.1		μs
t _f	Fall time			0.4		μs

◆ h_{FE-1} Classifications

Q	R	S
70-140	100-200	140-280

Silicon PNP Power Transistors

2SB828

PACKAGE OUTLINE

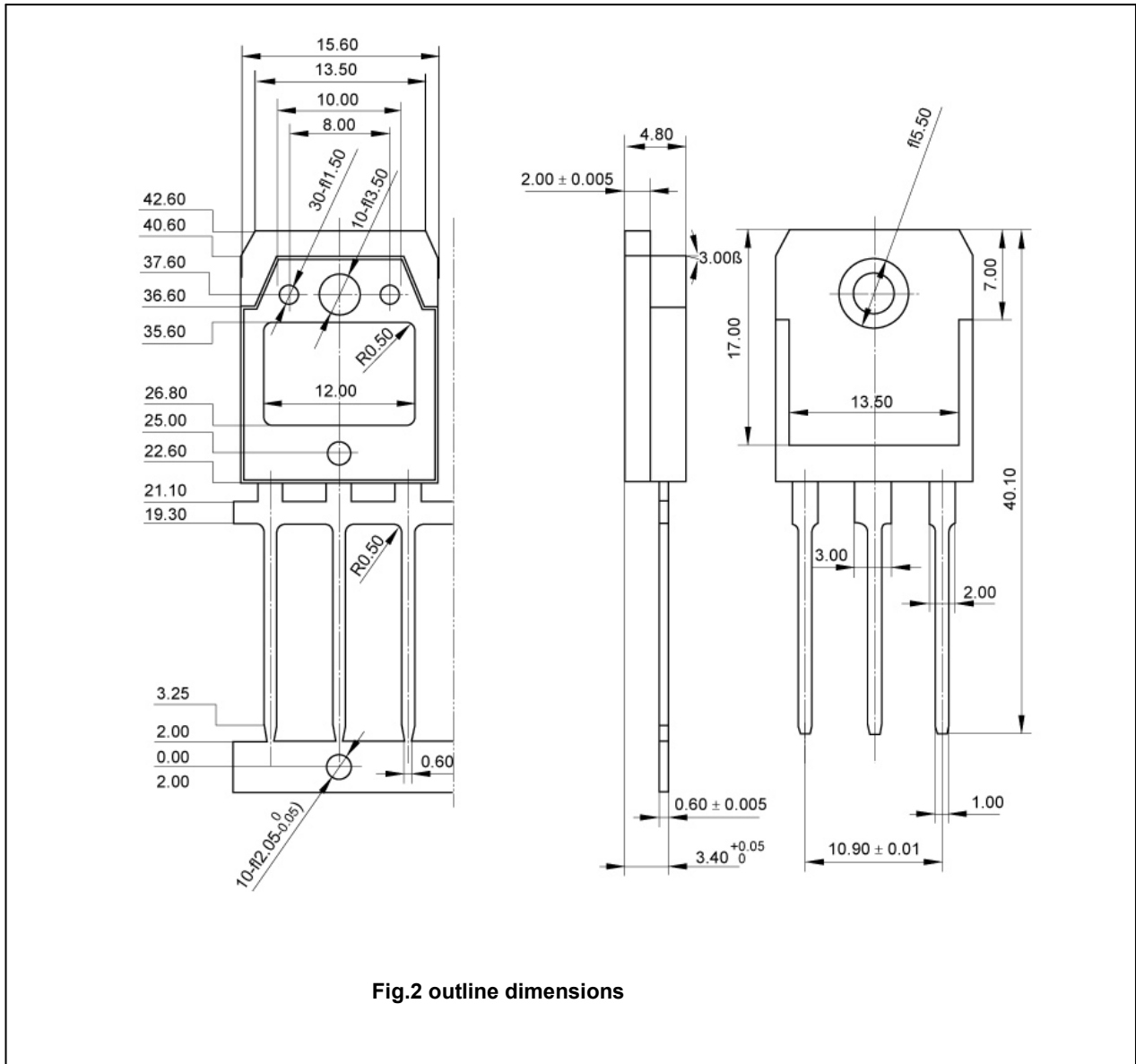

Fig.2 outline dimensions

Silicon PNP Power Transistors

2SB828

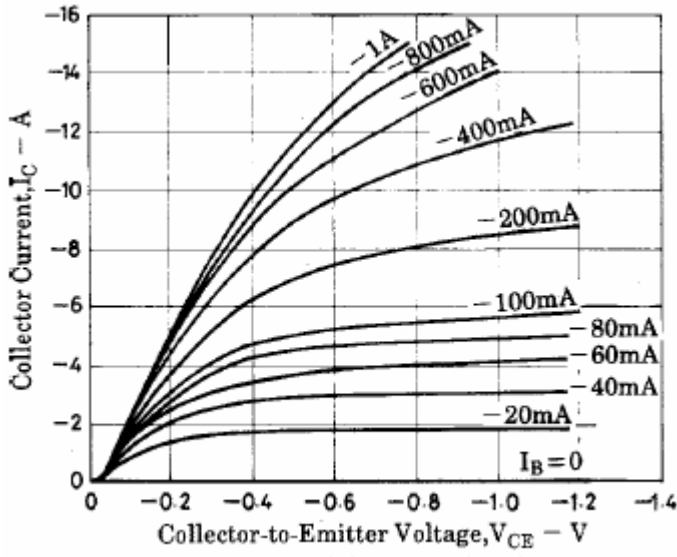

Fig.3 Static Characteristic

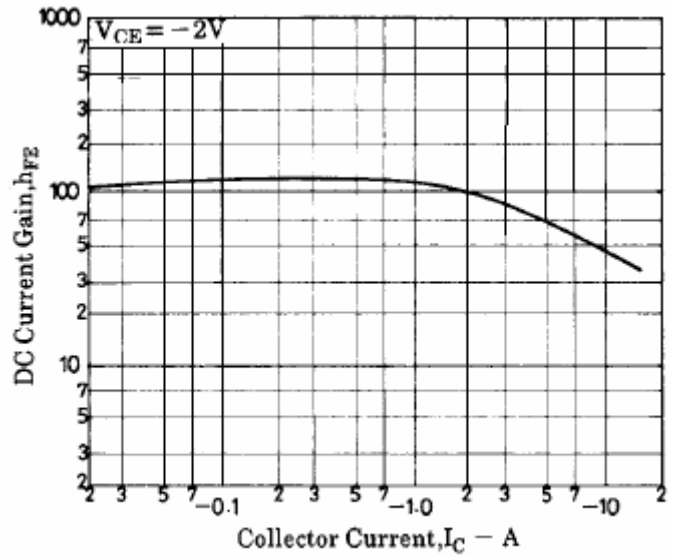

Fig.4 DC current Gain

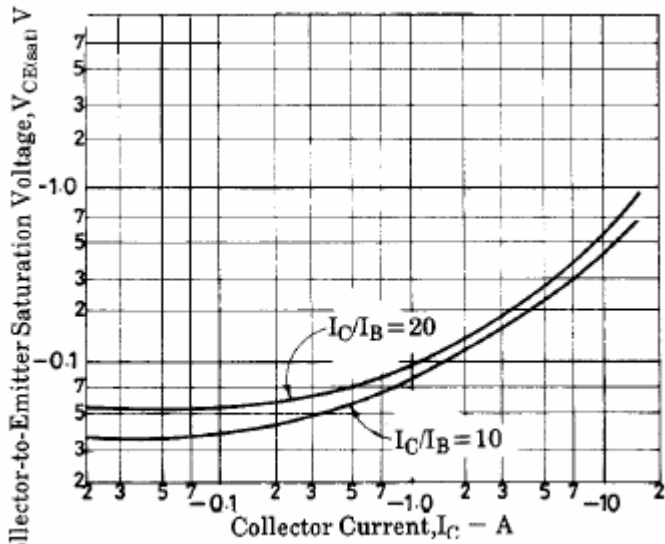

Fig.5 Collector-Emitter Saturation Voltage

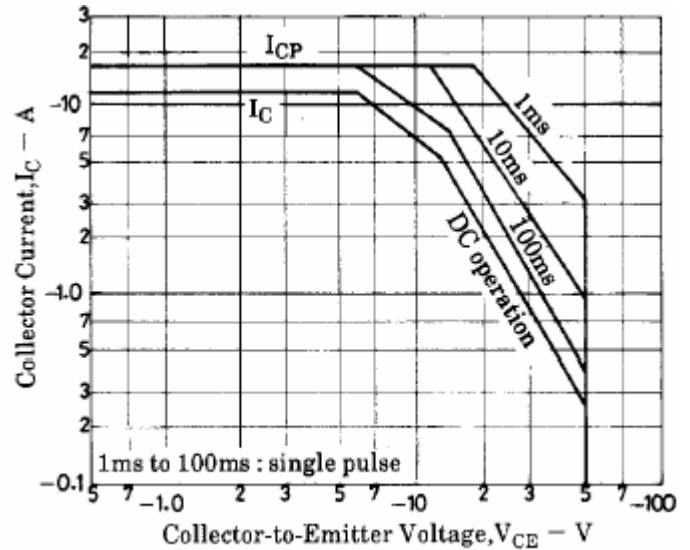

Fig.6 Safe Operating Area