

Silicon NPN Power Transistors

2SC2258A

DESCRIPTION

- With TO-126 package
- High transition frequency f_T
- High collector-emitter voltage V_{CE0}

APPLICATIONS

- High voltage general amplifier
- TV video output amplifier

PINNING

PIN	DESCRIPTION
1	Emitter
2	Collector;connected to mounting base
3	Base

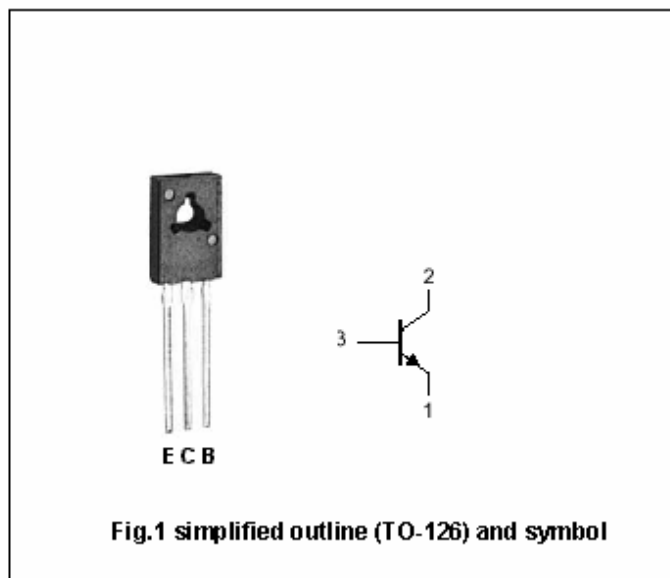

Absolute maximum ratings($T_a=25^\circ C$)

SYMBOL	PARAMETER	CONDITIONS	VALUE	UNIT
V_{CBO}	Collector-base voltage	Open emitter	300	V
V_{CEO}	Collector- emitter voltage	Open base	300	V
V_{EBO}	Emitter-base voltage	Open collector	7	V
I_C	Collector current		0.1	A
I_{CM}	Collector current-peak		0.15	A
P_C	Collector power dissipation	$T_C=25^\circ C$	1.2^{*1}	W
			4^{*2}	
T_j	Junction temperature		150	$^\circ C$
T_{stg}	Storage temperature		$-55^\circ C+150$	$^\circ C$

Note :*1: Without heat sink

*2: With a 100 × 100 × 2 mm A1 heat sink

Silicon NPN Power Transistors

2SC2258A

CHARACTERISTICS

T_j=25°C unless otherwise specified

SYMBOL	PARAMETER	CONDITIONS	MIN	TYP.	MAX	UNIT
I _{CER}	Collector cutoff current	V _{CE} =250V; R _{BE} =100kΩ			100	μA
V _{(BR)EBO}	Emitter-base breakdown voltage	I _E =0.1mA ; I _C =0	7			V
V _{CEsat}	Collector-emitter saturation voltage	I _C =50mA ; I _B =5mA			1.2	V
V _{BE}	Base-emitter voltage	I _C =40mA ; V _{CE} =20V			1.2	V
h _{FE-1}	DC current gain	I _C =40mA ; V _{CE} =20V	40			
h _{FE-2}	DC current gain	I _C =5mA ; V _{CE} =50V	30			
C _{OB}	Output capacitance	I _E =0; V _{CB} =50V; f=1MHz		3	4.5	pF
f _T	Transition frequency	I _E =-10mA ; V _{CE} =10V		100		MHz

Silicon NPN Power Transistors

2SC2258A

PACKAGE OUTLINE

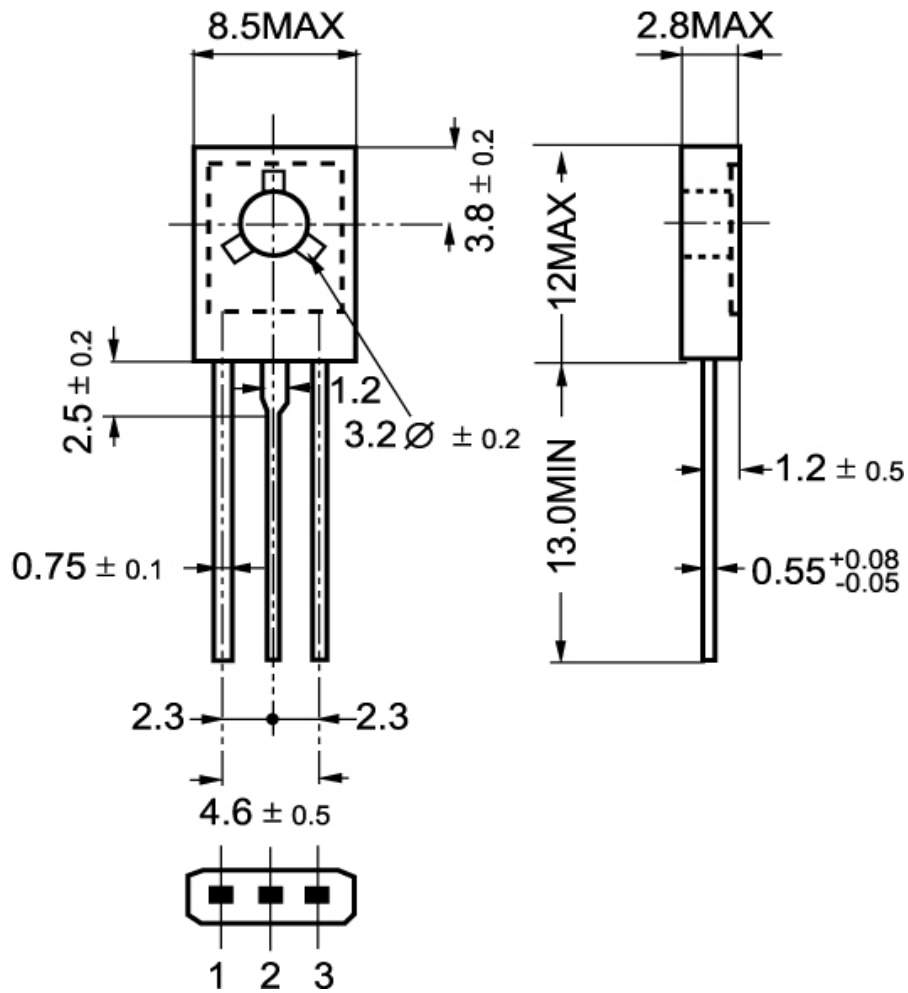

Fig.2 Outline dimensions