

Red Enhanced Ultra Low Capacitance Silicon Photodiode

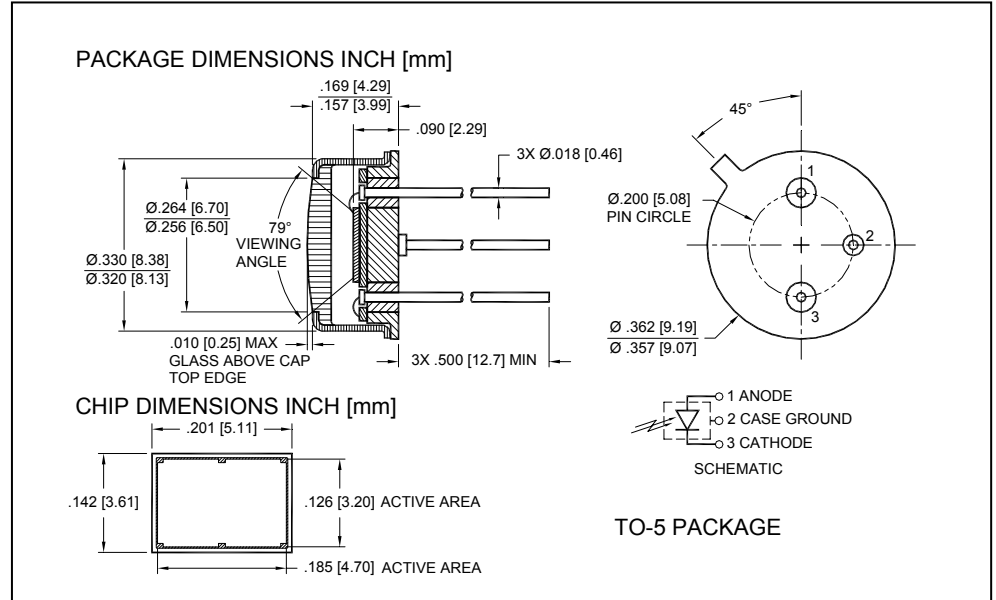

FEATURES

- Low noise
- Red enhanced
- High shunt resistance
- High response

DESCRIPTION

The **SD 172-11-31-221** is an ultra low capacitance silicon PIN photodiode, red enhanced, packaged in a leaded hermetic TO-5 metal package.

APPLICATIONS

- Military
- Industrial
- Medical

ABSOLUTE MAXIMUM RATING (TA)= 23°C UNLESS OTHERWISE NOTED

SYMBOL	PARAMETER	MIN	MAX	UNITS
V _{BR}	Reverse Voltage		75	V
T _{STG}	Storage Temperature	-55	+150	°C
T _O	Operating Temperature	-40	+125	°C
T _S	Soldering Temperature*		+240	°C

* 1/16 inch from case for 3 seconds max.

SPECTRAL RESPONSE

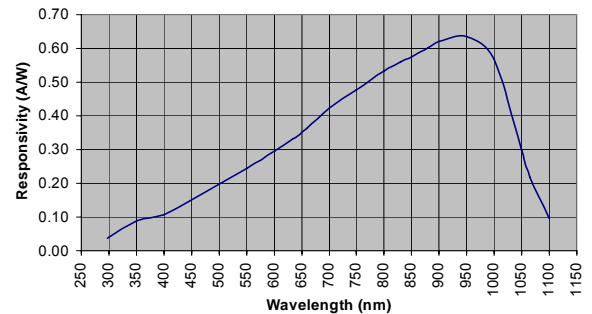

ELECTRO-OPTICAL CHARACTERISTICS RATING (TA)= 23°C UNLESS OTHERWISE NOTED

SYMBOL	CHARACTERISTIC	TEST CONDITIONS	MIN	TYP	MAX	UNITS
I _D	Dark Current	V _R = 50V		35	147	nA
C _J	Junction Capacitance	V _R = 0V, f = 1 MHz		82		pF
		V _R = 50V, f = 1 MHz		10		
λ range	Spectral Application Range	Spot Scan	350		1100	nm
R	Responsivity	λ = 900nm, V _R = 0 V	0.50	0.55		A/W
V _{BR}	Breakdown Voltage	I = 10 μA		75		V
NEP	Noise Equivalent Power	V _R = 5V @ λ = 950nm		2.0 x 10 ⁻¹³		W/√Hz
t _r	Response Time**	RL = 50 Ω, V _R = 0 V		190		nS
		RL = 50 Ω, V _R = 50 V		8		

**Response time of 10% to 90% is specified at 660nm wavelength light.

Information in this technical datasheet is believed to be correct and reliable. However, no responsibility is assumed for possible inaccuracies or omission. Specifications are subject to change without notice.