

Silicon PNP Power Transistors

TIP2955

DESCRIPTION

- With TO-3PN package
- Complement to type TIP3055
- 90 W at 25°C case temperature
- 15 A continuous collector current

APPLICATIONS

- Designed for general-purpose switching and amplifier applications.

PINNING

PIN	DESCRIPTION
1	Base
2	Collector; connected to mounting base
3	Emitter

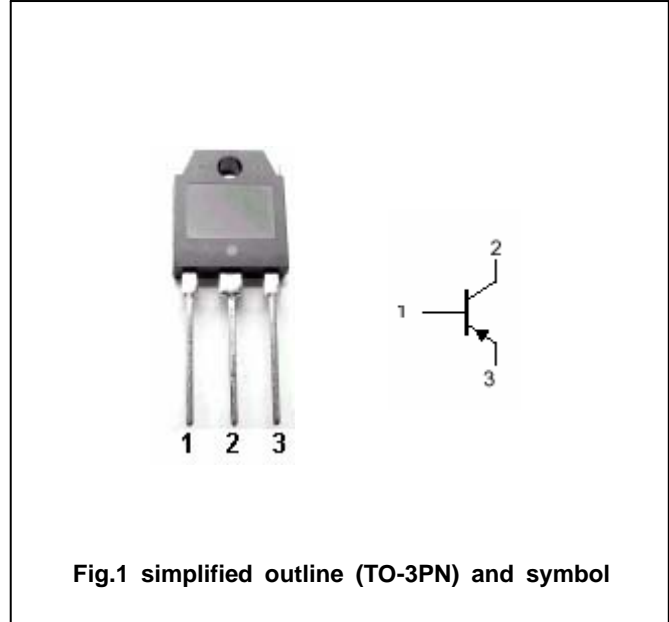

Fig.1 simplified outline (TO-3PN) and symbol

Absolute maximum ratings($T_a =$)

SYMBOL	PARAMETER	CONDITIONS	VALUE	UNIT
V_{CBO}	Collector-base voltage	Open emitter	-100	V
V_{CEO}	Collector-emitter voltage	Open base	-60	V
V_{EBO}	Emitter-base voltage	Open collector	-7	V
I_C	Collector current		-15	A
I_B	Base current		-7	A
P_C	Collector power dissipation	$T_C=25$	90	W
T_j	Junction temperature		150	
T_{stg}	Storage temperature		-65~150	

THERMAL CHARACTERISTICS

SYMBOL	PARAMETER	VALUE	UNIT
$R_{th\ j-c}$	Thermal resistance junction to case	1.39	/W

Silicon PNP Power Transistors

TIP2955

CHARACTERISTICS

T_j=25 unless otherwise specified

SYMBOL	PARAMETER	CONDITIONS	MIN	TYP.	MAX	UNIT
V _{CEO(SUS)}	Collector-emitter sustaining voltage	I _C =-30mA ; I _B =0	-60			V
V _{CEsat-1}	Collector-emitter saturation voltage	I _C =-4A ; I _B =-0.4A			-1.1	V
V _{CEsat-2}	Collector-emitter saturation voltage	I _C =-10A ; I _B =-3.3A			-3.0	V
V _{BE}	Base-emitter on voltage	I _C =-4A ; V _{CE} =-4V			-1.5	V
I _{CEO}	Collector cut-off current	V _{CE} =-30V; I _B =0			-0.7	mA
I _{CER}	Collector cut-off current	V _{CE} =-70Vdc; R _{BE} =100Ohm			-1.0	mA
I _{CEV}	Collector cut-off current	V _{CE} =-100Vdc, V _{BE(off)} =-1.5Vdc			-5.0	mA
I _{EBO}	Emitter cut-off current	V _{EB} =-7V; I _C =0			-5.0	mA
h _{FE-1}	DC current gain	I _C =-4A ; V _{CE} =-4V	20		70	
h _{FE-2}	DC current gain	I _C =-10A ; V _{CE} =-4V	5.0			
I _{s/b}	Second breakdown collector current With base forward biased	V _{CE} =-30Vdc, t=1.0s, Nonrepetitive	3.0			A
f _T	Transition frequency	I _C =-0.5A ; V _{CE} =-10V	2.5			MHz

Silicon PNP Power Transistors

TIP2955

PACKAGE OUTLINE

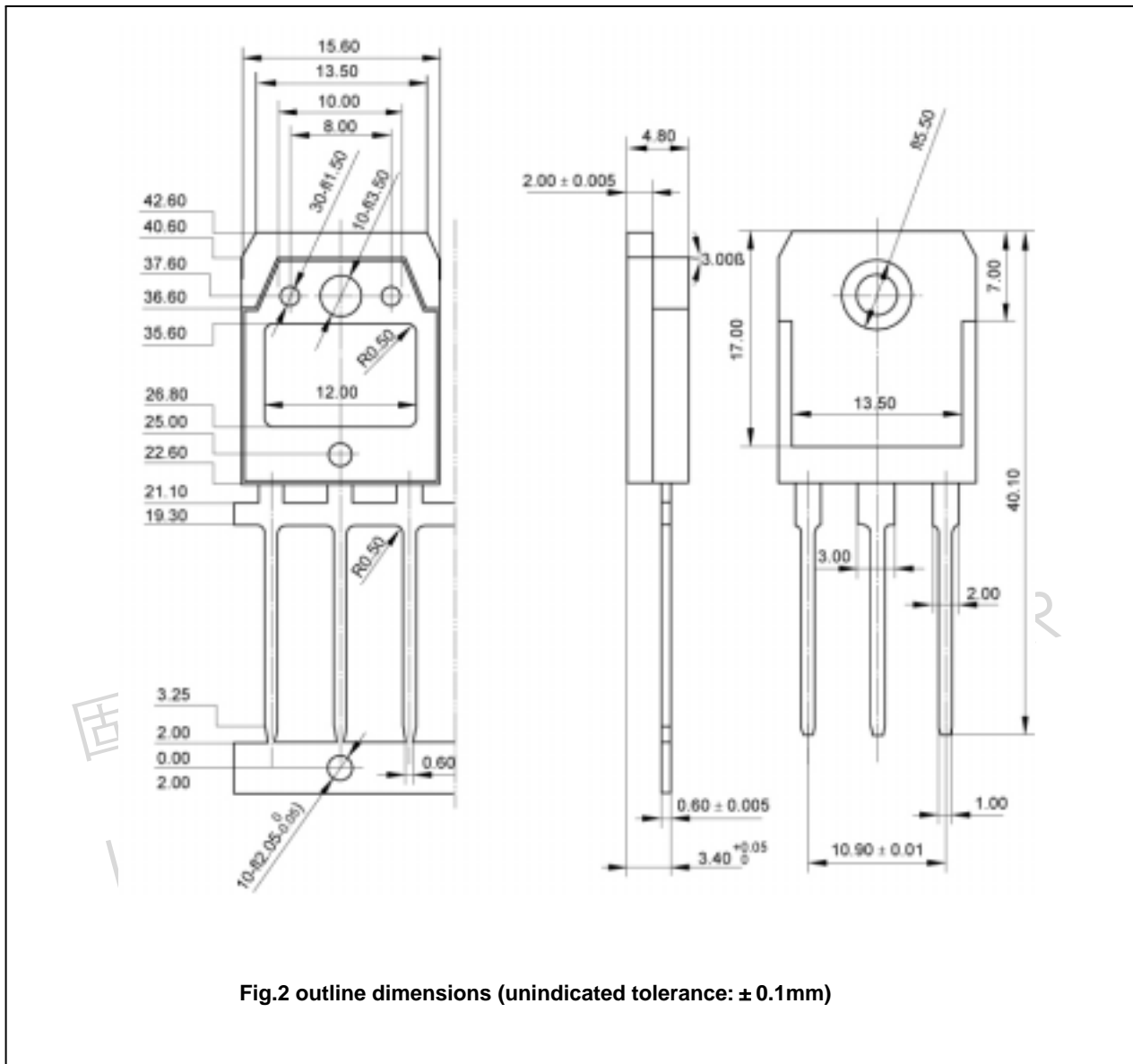

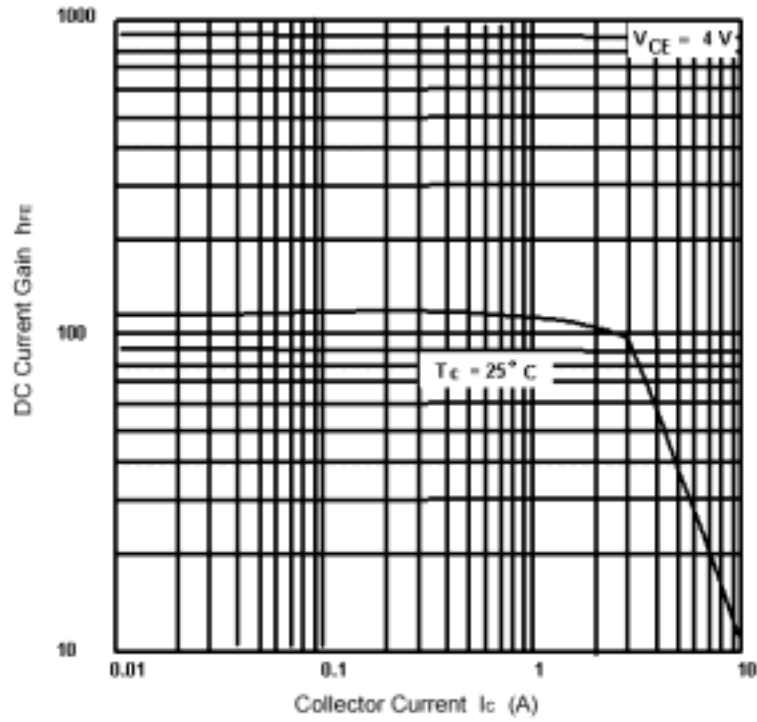

Fig.3 DC current Gain

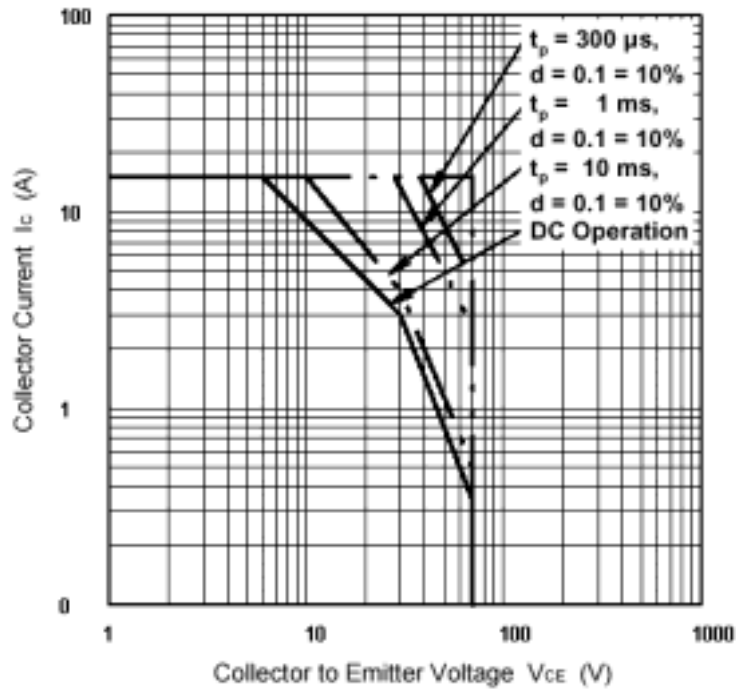

Fig.4 Safe Operating Area