

Silicon NPN Power Transistors

2SD1885

DESCRIPTION

- With TO-3PML package
- High breakdown voltage
- High reliability
- High speed

APPLICATIONS

- Color TV horizontal deflection output.
- Color display horizontal deflection output.

PINNING

PIN	DESCRIPTION
1	Base
2	Collector
3	Emitter

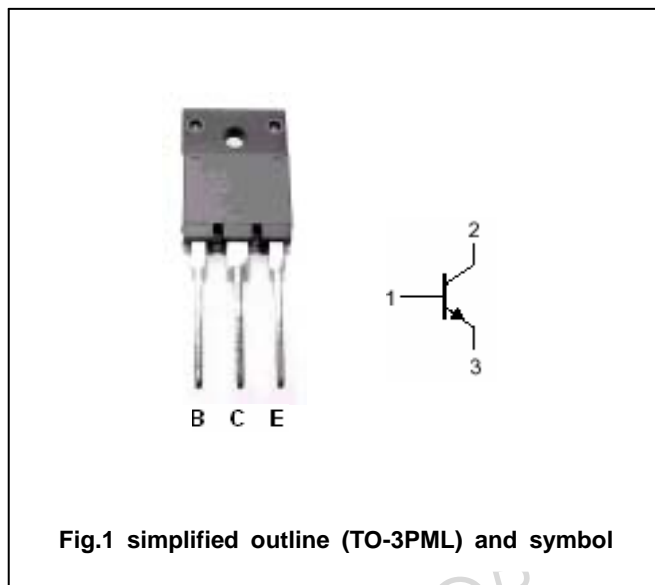

Fig.1 simplified outline (TO-3PML) and symbol

Absolute maximum ratings(Ta=25)

SYMBOL	PARAMETER	CONDITIONS	VALUE	UNIT
V _{CBO}	Collector-base voltage	Open emitter	1500	V
V _{CEO}	Collector-emitter voltage	Open base	800	V
V _{EBO}	Emitter-base voltage	Open collector	6	V
I _C	Collector current		6	A
I _{CM}	Collector current-peak		20	A
P _C	Collector power dissipation		3.0	W
		T _C =25	60	
T _j	Junction temperature		150	
T _{stg}	Storage temperature		-55~150	

Silicon NPN Power Transistors

2SD1885

CHARACTERISTICS

T_j=25 unless otherwise specified

SYMBOL	PARAMETER	CONDITIONS	MIN	TYP.	MAX	UNIT
V _{CEsat}	Collector-emitter saturation voltage	I _C =5A; I _B =1 A			5	V
V _{BEsat}	Base-emitter saturation voltage	I _C =5A; I _B =1 A			1.5	V
V _{CEO(SUS)}	Collector-emitter sustaining voltage	I _C =100mA; I _B =0	800			V
I _{EBO}	Emitter cut-off current	V _{EB} =4V; I _C =0			1	mA
I _{CBO}	Collector cut-off current	V _{CB} =800V; I _E =0			10	μA
I _{CES}	Collector cut-off current	V _{CE} =1500V; R _{BE} =0			1	mA
h _{FE-1}	DC current gain	I _C =1 A ; V _{CE} =5V	8			
h _{FE-2}	DC current gain	I _C =5A ; V _{CE} =5V	5		10	
t _f	Fall time	I _C =4A; R _L =50 ; I _{B1} =0.8A I _{B2} =-1.6A V _{CC} =200V		0.1	0.3	μs

Silicon NPN Power Transistors

2SD1885

PACKAGE OUTLINE

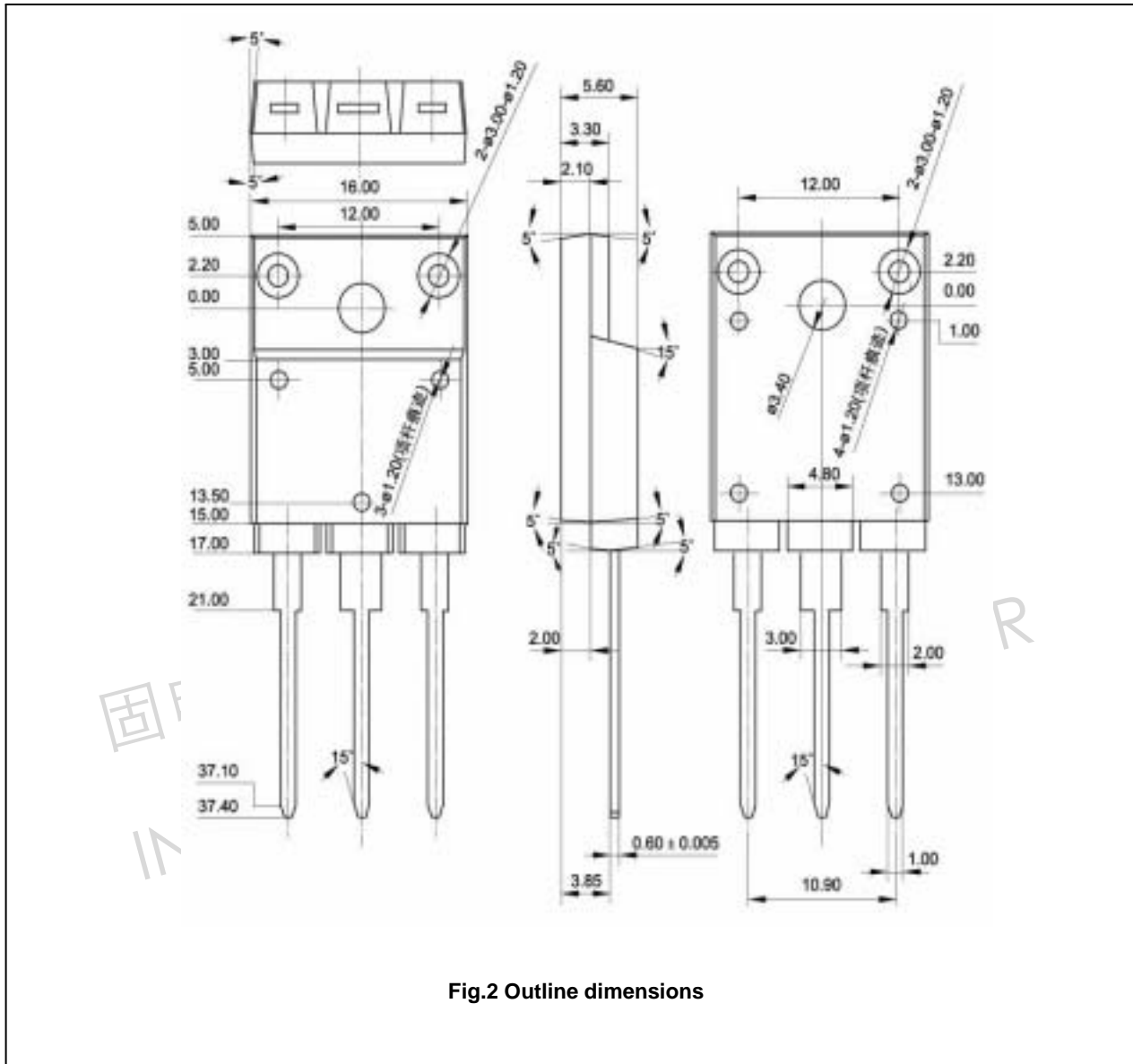

Fig.2 Outline dimensions

Silicon NPN Power Transistors

2SD1885

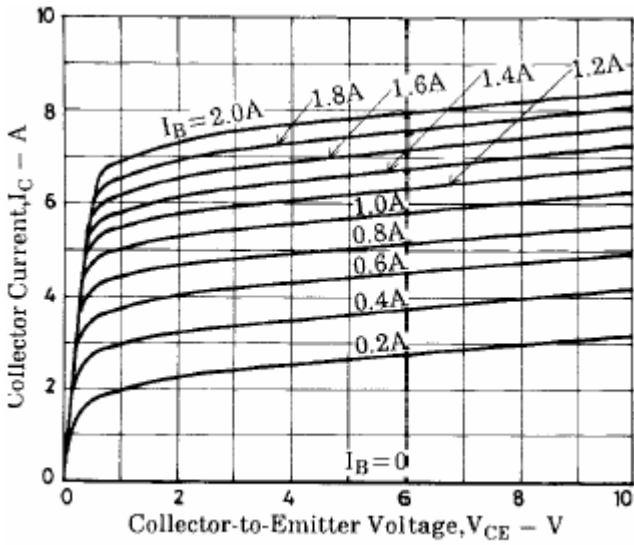

Fig.3 Static Characteristic

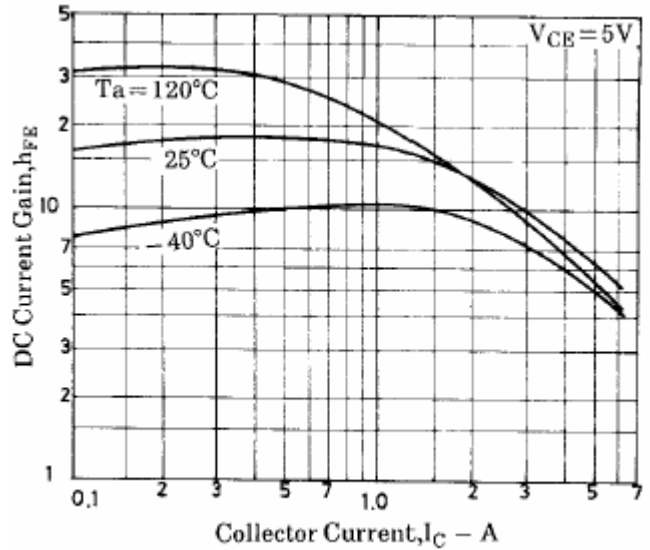

Fig.4 DC current Gain

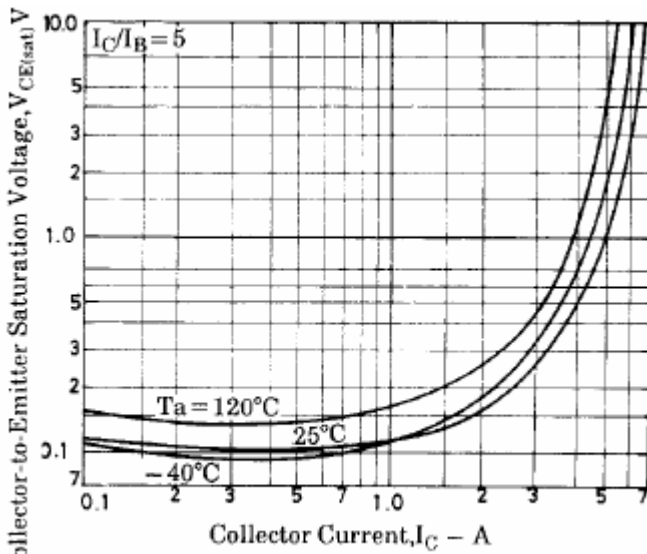

Fig.5 Collector-Emitter Saturation Voltage

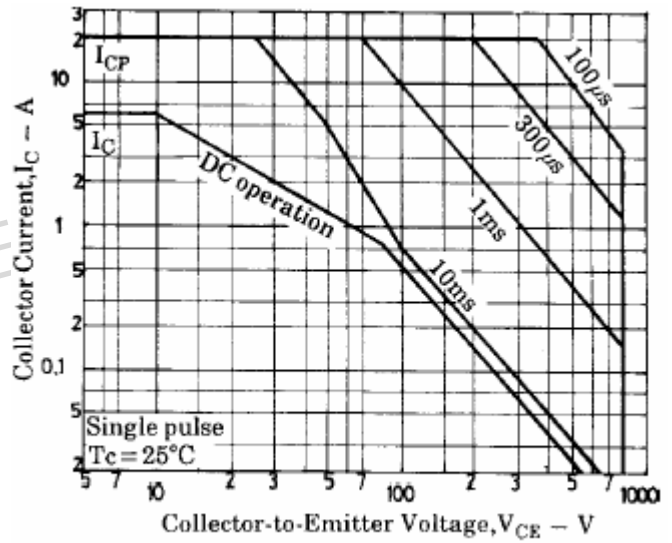

Fig.6 Safe Operating Area