

HD74LV4053A

Triple 2-channel Analog Multiplexer / Demultiplexer

REJ03D0339-0300Z
 (Previous ADE-205-284A (Z))
 Rev.3.00
 Jul. 21, 2004

Description

The HD74LV4053A handles both analog and digital signals, and enables signals of either type with amplitudes of up to 5.5 V (peak) to be transmitted in either direction (at $V_{CC} = 0\text{ V}$ to 5.5 V).

Applications include signal gating, chopping, modulation or demodulation (modem), and signal multiplexing for analog-to-digital and digital-to-analog conversion systems.

Features

- $V_{CC} = 2.0\text{ V}$ to 5.5 V operation
- All control inputs V_{IH} (Max.) = 5.5 V (@ $V_{CC} = 0\text{ V}$ to 5.5 V)
- Ordering Information

Part Name	Package Type	Package Code	Package Abbreviation	Taping Abbreviation (Quantity)
HD74LV4053AFPEL	SOP-16 pin (JEITA)	FP-16DAV	FP	EL (2,000 pcs/reel)
HD74LV4053ARPEL	SOP-16 pin (JEDEC)	FP-16DNV	RP	EL (2,500 pcs/reel)
HD74LV4053ATELL	TSSOP-16 pin	TTP-16DAV	T	ELL (2,000 pcs/reel)

Note: Please consult the sales office for the above package availability.

Function Table

Inputs				On Channel
INH	C	B	A	
L	L	L	L	1Y0, 2Y0, 3Y0
L	L	L	H	1Y1, 2Y0, 3Y0
L	L	H	L	1Y0, 2Y1, 3Y0
L	L	H	H	1Y1, 2Y1, 3Y0
L	H	L	L	1Y0, 2Y0, 3Y1
L	H	L	H	1Y1, 2Y0, 3Y1
L	H	H	L	1Y0, 2Y1, 3Y1
L	H	H	H	1Y1, 2Y1, 3Y1
H	X	X	X	NONE

Note: H: High level
 L: Low level
 X: Immaterial

Pin Arrangement

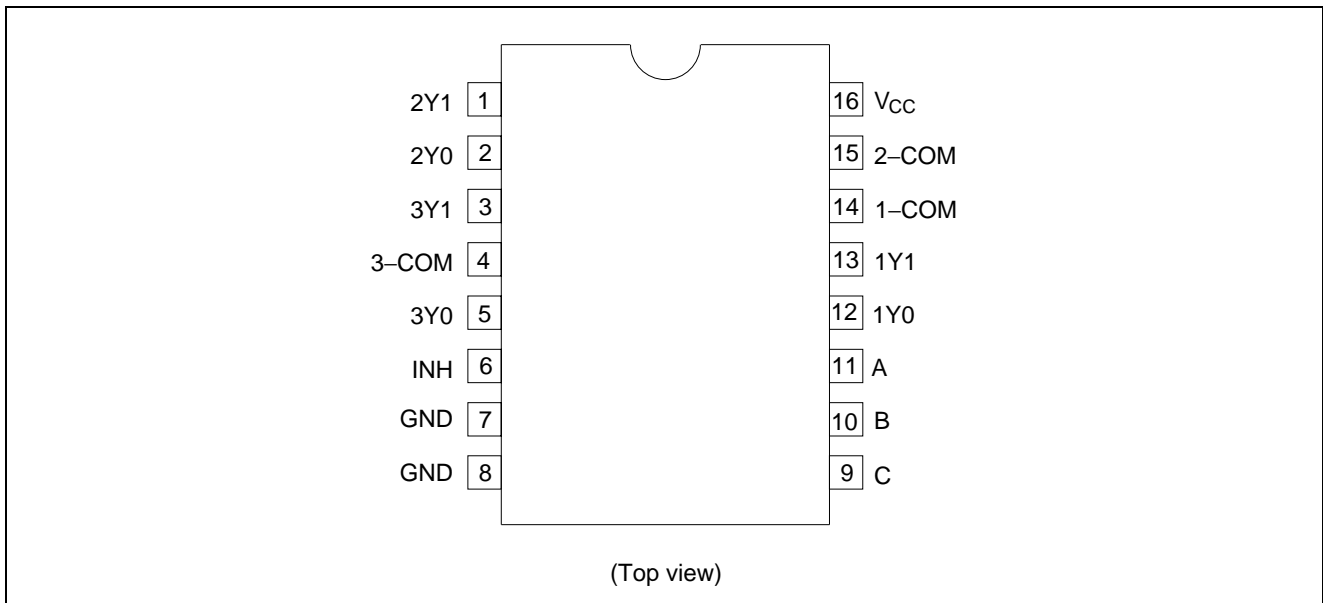

Absolute Maximum Ratings

Item	Symbol	Ratings	Unit	Conditions
Supply voltage range	V_{CC}	-0.5 to 7.0	V	
Input voltage range* ¹	V_I	-0.5 to 7.0	V	
Output voltage range* ^{1,2}	V_O	-0.5 to $V_{CC} + 0.5$	V	Output: H or L
Input clamp current	I_{IK}	-20	mA	$V_I < 0$
Output clamp current	I_{OK}	± 50	mA	$V_O < 0$ or $V_O > V_{CC}$
Continuous output current	I_O	± 25	mA	$V_O = 0$ to V_{CC}
Continuous current through V_{CC} or GND	I_{CC} or I_{GND}	± 50	mA	
Maximum power dissipation at $T_a = 25^\circ\text{C}$ (in still air)* ³	P_T	785	mW	SOP
		500		TSSOP
Storage temperature	T_{stg}	-65 to 150	$^\circ\text{C}$	

Notes: The absolute maximum ratings are values, which must not individually be exceeded, and furthermore, no two of which may be realized at the same time.

1. The input and output voltage ratings may be exceeded even if the input and output clamp-current ratings are observed.
2. This value is limited to 5.5 V maximum.
3. The maximum package power dissipation was calculated using a junction temperature of 150°C.

Recommended Operating Conditions

Item	Symbol	Min	Max	Unit	Conditions
Supply voltage range	V_{CC}	2.0* ¹	5.5	V	
Input voltage range	V_I	0	5.5	V	
Output voltage range	V_{IO}	0	V_{CC}	V	
Input transition rise or fall rate	$\Delta t / \Delta v$	0	200	ns/V	$V_{CC} = 2.3 \text{ to } 2.7 \text{ V}$
		0	100		$V_{CC} = 3.0 \text{ to } 3.6 \text{ V}$
		0	20		$V_{CC} = 4.5 \text{ to } 5.5 \text{ V}$
Operating free-air temperature	T_a	-40	85	°C	

Notes: Unused or floating control inputs must be held high or low.

1. With the supply voltage at or around 2 V, the analog switch on-state resistance loses linearity significantly. It is recommended that only digital signals be transmitted at these low supply voltages.

Logic Diagram

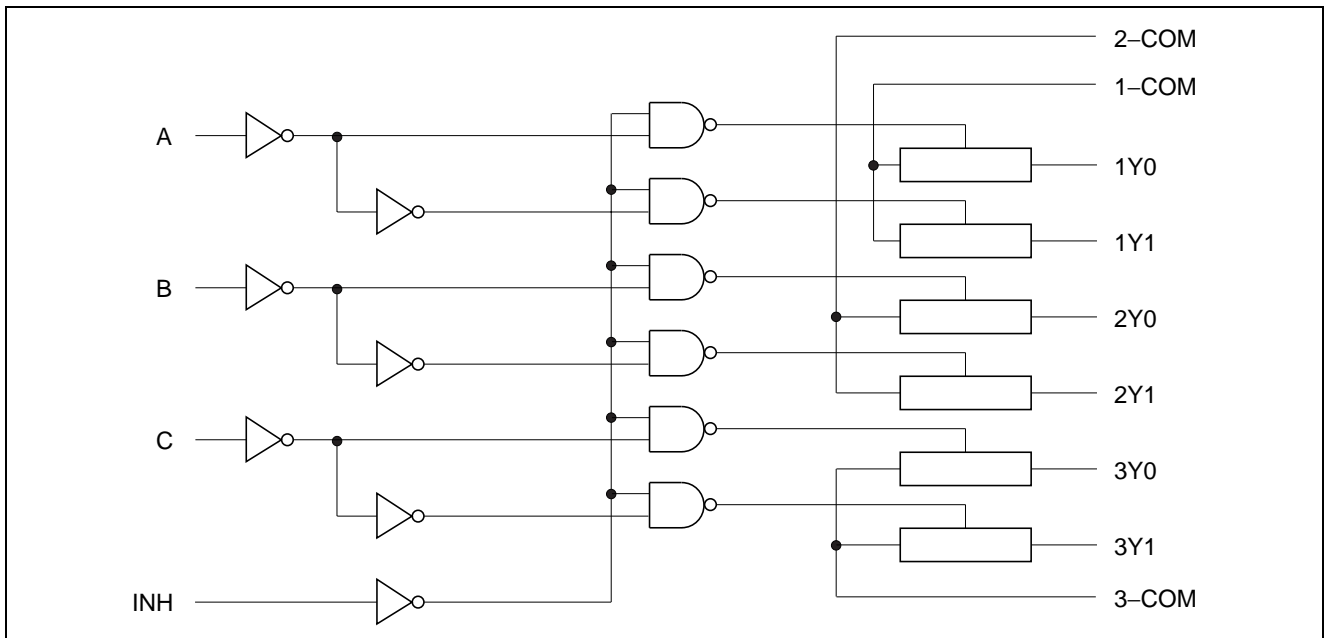

DC Electrical Characteristics

Item	Symbol	V _{CC} (V)	Ta = 25°C			Ta = -40 to 85°C		Unit	Test Conditions
			Min	Typ	Max	Min	Max		
Input voltage	V _{IH}	2.0	—	—	—	1.5	—	V	Control input only
		2.3 to 2.7	—	—	—	V _{CC} × 0.7	—		
		3.0 to 3.6	—	—	—	V _{CC} × 0.7	—		
		4.5 to 5.5	—	—	—	V _{CC} × 0.7	—		
	V _{IL}	2.0	—	—	—	—	0.5		
		2.3 to 2.7	—	—	—	—	V _{CC} × 0.3		
		3.0 to 3.6	—	—	—	—	V _{CC} × 0.3		
		4.5 to 5.5	—	—	—	—	V _{CC} × 0.3		
On-state switch resistance	R _{ON}	2.3	—	60	180	—	225	Ω	V _{IN} = V _{CC} or GND
		3.0	—	50	150	—	190		V _{INH} = V _{IL}
		4.5	—	40	75	—	100		I _T = 2 mA
Peak on resistance	R _{ON (P)}	2.3	—	200	500	—	600	Ω	V _{IN} = V _{CC} to GND
		3.0	—	90	180	—	225		V _{INH} = V _{IL}
		4.5	—	50	100	—	125		I _T = 2 mA
Difference of on-state resistance between switches	ΔR _{ON}	2.3	—	20	30	—	40	Ω	V _{IN} = V _{CC} to GND
		3.0	—	10	20	—	30		V _{INH} = V _{IL}
		4.5	—	7	15	—	20		I _T = 2 mA
Off-state switch leakage current	I _{s (OFF)}	5.5	—	—	±0.1	—	±1.0	μA	V _{IN} = V _{CC} , V _{OUT} = GND or V _{IN} = GND, V _O = V _{CC} , V _{INH} = V _{IH}
On-state switch leakage current	I _{s (ON)}	5.5	—	—	±0.1	—	±1.0	μA	V _{IN} = V _{CC} or GND V _{INH} = V _{IL}
Input current	I _{IN}	0 to 5.5	—	—	±0.1	—	±1.0	μA	V _{IN} = 5.5 V or GND
Quiescent supply current	I _{CC}	5.5	—	—	—	—	20	μA	V _{IN} = V _{CC} or GND

Note: For conditions shown as Min or Max, use the appropriate values under recommended operating conditions.

Switching Characteristics

$V_{CC} = 2.5 \pm 0.2 \text{ V}$

Item	Symbol	Ta = 25°C			Ta = -40 to 85°C		Unit	Test Conditions	FROM (Input)	TO (Output)
		Min	Typ	Max	Min	Max				
Propagation delay time	t _{PLH}	—	2.5	10.0	—	16.0	ns	C _L = 15 pF	COM or Yn	Yn or COM
	t _{PHL}	—	5.0	12.0	—	18.0		C _L = 50 pF		
Enable time	t _{ZH}	—	7.0	18.0	—	23.0	ns	R _L = 1 kΩ C _L = 15 pF	INH	COM or Yn
	t _{ZL}	—	9.0	28.0	—	35.0				
Disable time	t _{HZ}	—	9.0	18.0	—	23.0	ns	R _L = 1 kΩ C _L = 15 pF	INH	COM or Yn
	t _{LZ}	—	13.0	28.0	—	35.0				

$V_{CC} = 3.3 \pm 0.3 \text{ V}$

Item	Symbol	Ta = 25°C			Ta = -40 to 85°C		Unit	Test Conditions	FROM (Input)	TO (Output)
		Min	Typ	Max	Min	Max				
Propagation delay time	t _{PLH}	—	2.0	6.0	—	10.0	ns	C _L = 15 pF	COM or Yn	Yn or COM
	t _{PHL}	—	4.0	9.0	—	12.0		C _L = 50 pF		
Enable time	t _{ZH}	—	5.0	12.0	—	15.0	ns	R _L = 1 kΩ C _L = 15 pF	INH	COM or Yn
	t _{ZL}	—	7.0	20.0	—	25.0				
Disable time	t _{HZ}	—	7.0	12.0	—	15.0	ns	R _L = 1 kΩ C _L = 15 pF	INH	COM or Yn
	t _{LZ}	—	10.0	20.0	—	25.0				

$V_{CC} = 5.0 \pm 0.5 \text{ V}$

Item	Symbol	Ta = 25°C			Ta = -40 to 85°C		Unit	Test Conditions	FROM (Input)	TO (Output)
		Min	Typ	Max	Min	Max				
Propagation delay time	t _{PLH}	—	1.5	4.0	—	7.0	ns	C _L = 15 pF	COM or Yn	Yn or COM
	t _{PHL}	—	3.0	6.0	—	8.0		C _L = 50 pF		
Enable time	t _{ZH}	—	4.0	8.0	—	10.0	ns	R _L = 1 kΩ C _L = 15 pF	INH	COM or Yn
	t _{ZL}	—	5.0	14.0	—	18.0				
Disable time	t _{HZ}	—	5.0	8.0	—	10.0	ns	R _L = 1 kΩ C _L = 15 pF	INH	COM or Yn
	t _{LZ}	—	8.0	14.0	—	18.0				

Switching Characteristics (cont.)

Item	Symbol	V _{CC} (V)	Ta = 25°C			Unit	Test Conditions	FROM (Input)	TO (Output)
			Min	Typ	Max				
Control input capacitance	C _{IC}	—	—	4.5	—	pF			
Common terminal capacitance	C _{IS}	—	—	12.5	—	pF			
Switch terminal capacitance	C _{I/O}	—	—	7.0	—	pF			
Feedthrough capacitance	C _T	—	—	0.5	—	pF			
Power dissipation capacitance	C _{PD}	—	—	9.0	—	pF			
Frequency response (Switch ON)		2.3	—	30.0	—	MHz	C _L = 50 pF, R _L = 600 Ω Adjust f _{in} voltage to obtain 0 dBm at output when f _{in} is 1 MHz (sine wave). Increase f _{in} frequency until the dB-meter reads -3 dBm. 20 log (V _O /V _I) = -3 dBm	COM or Yn	Yn or COM
		3.0	—	35.0	—				
		4.5	—	50.0	—				
Crosstalk (Between any switches)		2.3	—	-45.0	—	dB	C _L = 50 pF, R _L = 600 Ω Adjust f _{in} voltage to obtain 0 dBm at input when f _{in} is 1 MHz (sine wave).	COM	Yn
		3.0	—	-45.0	—				
		4.5	—	-45.0	—				
Crosstalk (Control input to signal output)		2.3	—	20.0	—	mV	C _L = 50 pF, R _L = 600 Ω Adjust R _L value to obtain 0 A at I _{IN/OUT} when f _{in} is 1 MHz (square wave).	INH	COM or Yn
		3.0	—	35.0	—				
		4.5	—	65.0	—				
Feedthrough attenuation (Switch OFF)		2.3	—	-45	—	dB	C _L = 50 pF, R _L = 600 Ω Adjust f _{in} voltage to obtain 0 dBm at input when f _{in} is 1 MHz (sine wave).	COM or Yn	Yn or COM
		3.0	—	-45	—				
		4.5	—	-45	—				
Sine-wave distortion		2.3	—	0.1	—	%	C _L = 50 pF, R _L = 10 kΩ f _{IN} = 1 kHz (sine wave) V _I = 2 V _{P-P} , V _{CC} = 2.3 V V _I = 2.5 V _{P-P} , V _{CC} = 3.0 V V _I = 4 V _{P-P} , V _{CC} = 4.5 V	COM or Yn	Yn or COM
		3.0	—	0.1	—				
		4.5	—	0.1	—				

Test Circuits

R_{ON}: On-state switch resistance

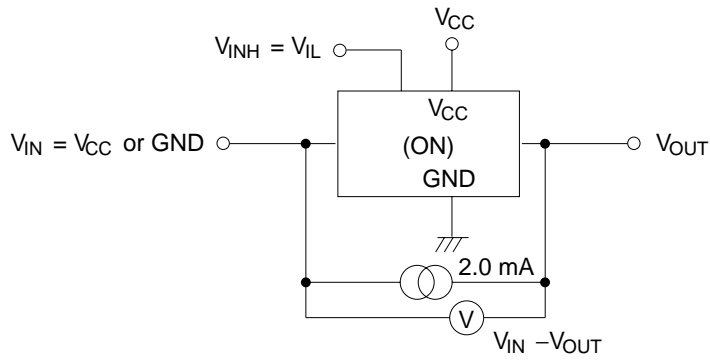

$$R_{ON} = \frac{V_{IN} - V_{OUT}}{2 \times 10^{-3}} (\Omega)$$

I_s (OFF): Off-state switch leakage current, I_s (ON): On-state switch leakage current

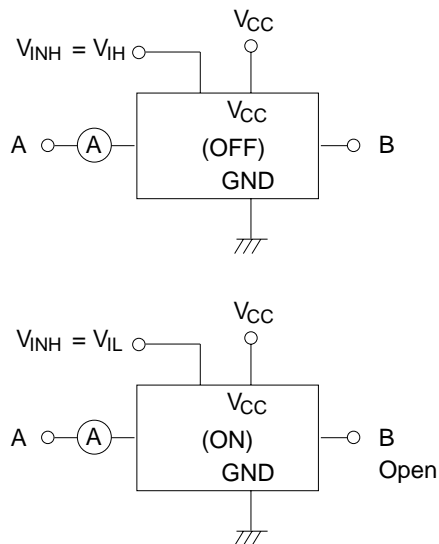

t_{PLH} , t_{PHL} : Propagation delay time (from switch input to switch output)

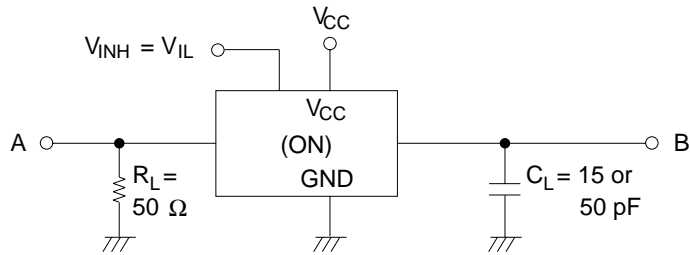

Switching time

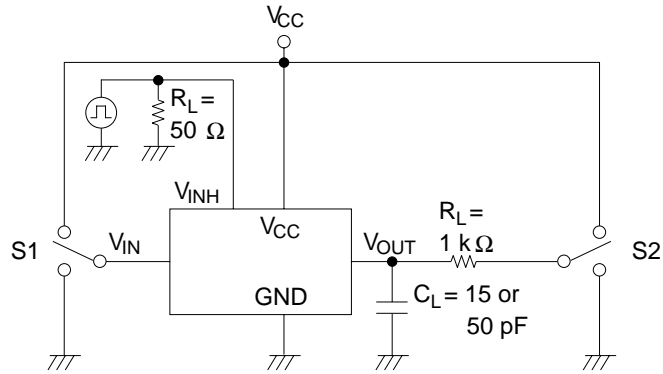

TEST	S1	S2
t_{LZ}/t_{ZL}	GND	VCC
t_{HZ}/t_{ZH}	VCC	GND

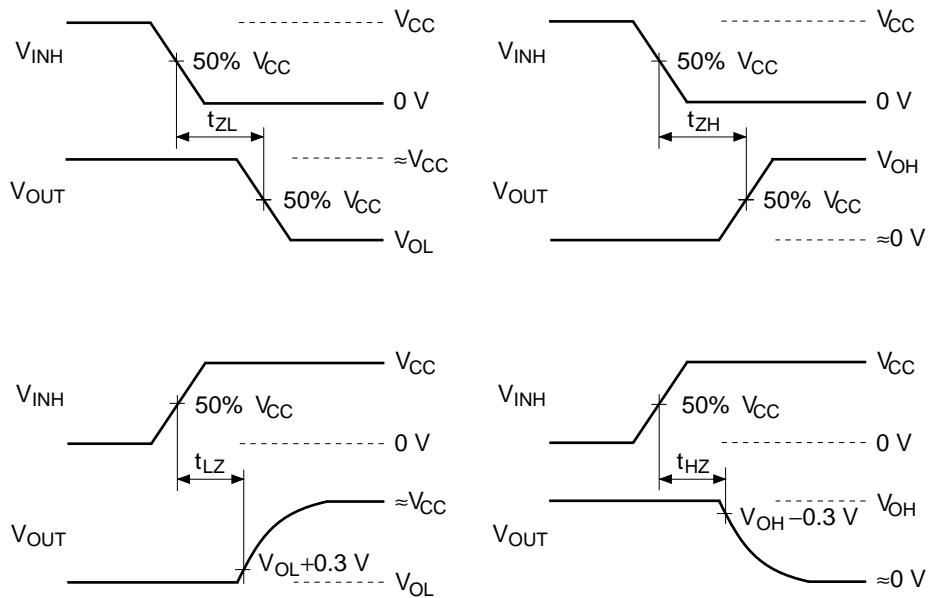

Frequency response (Switch ON)

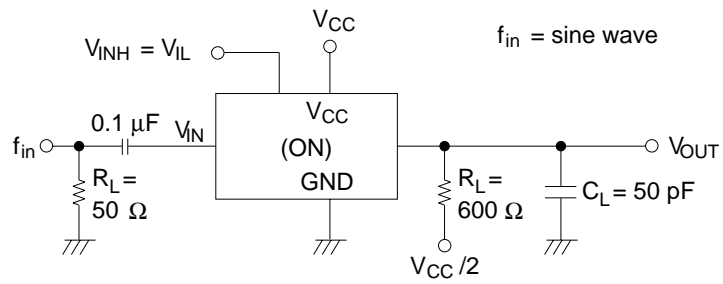

Crosstalk (Between any switches)

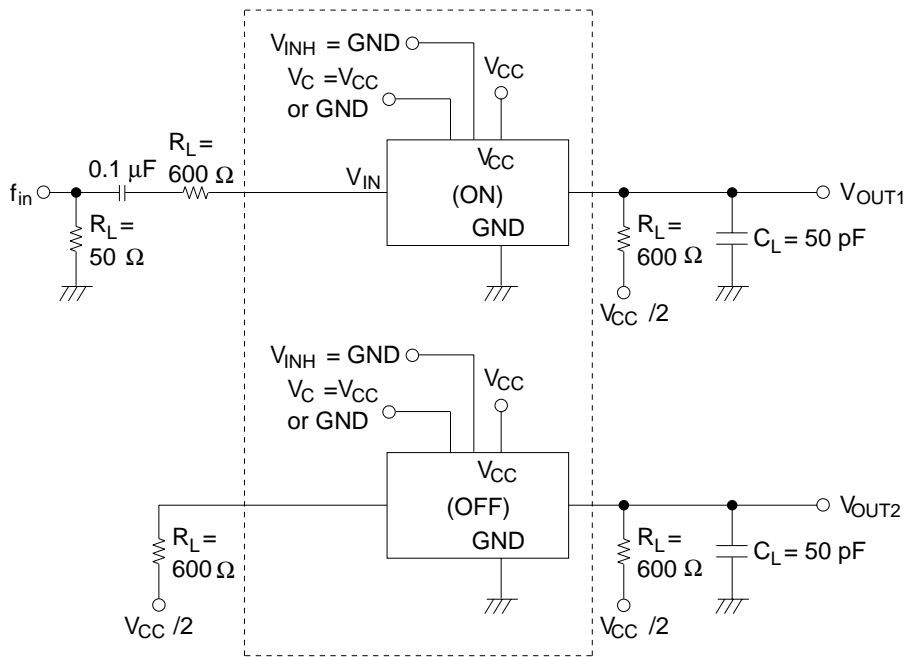

Crosstalk (Control input to signal output)

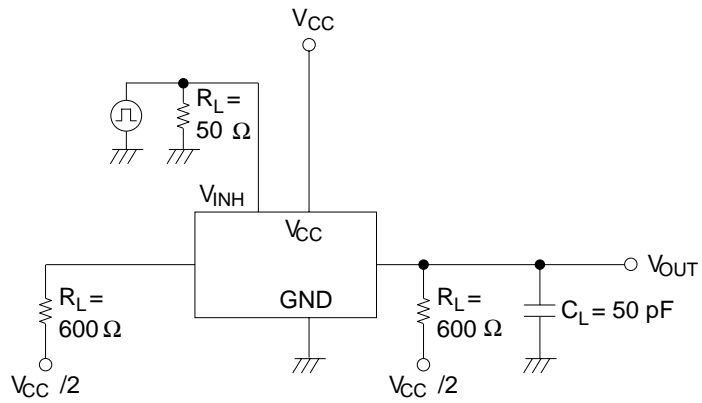

Feedthrough attenuation (Switch OFF)

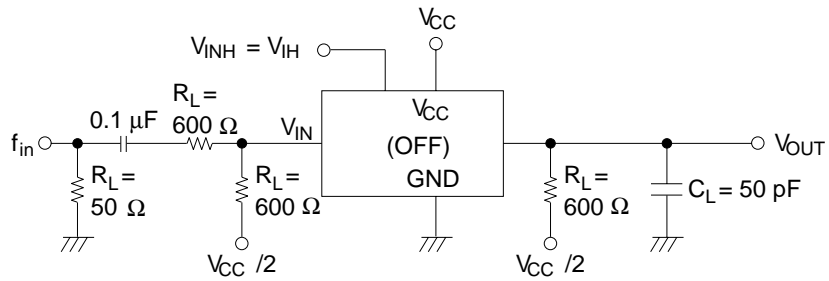

Sine-wave distortion

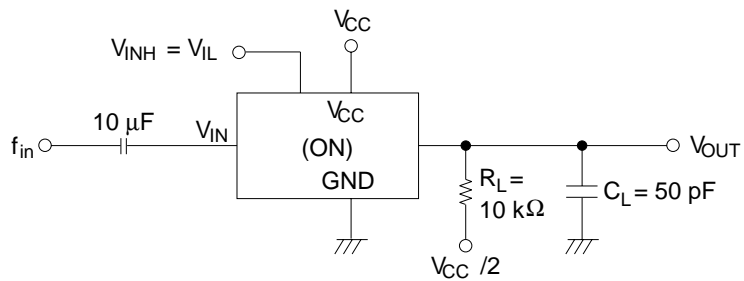

Package Dimensions

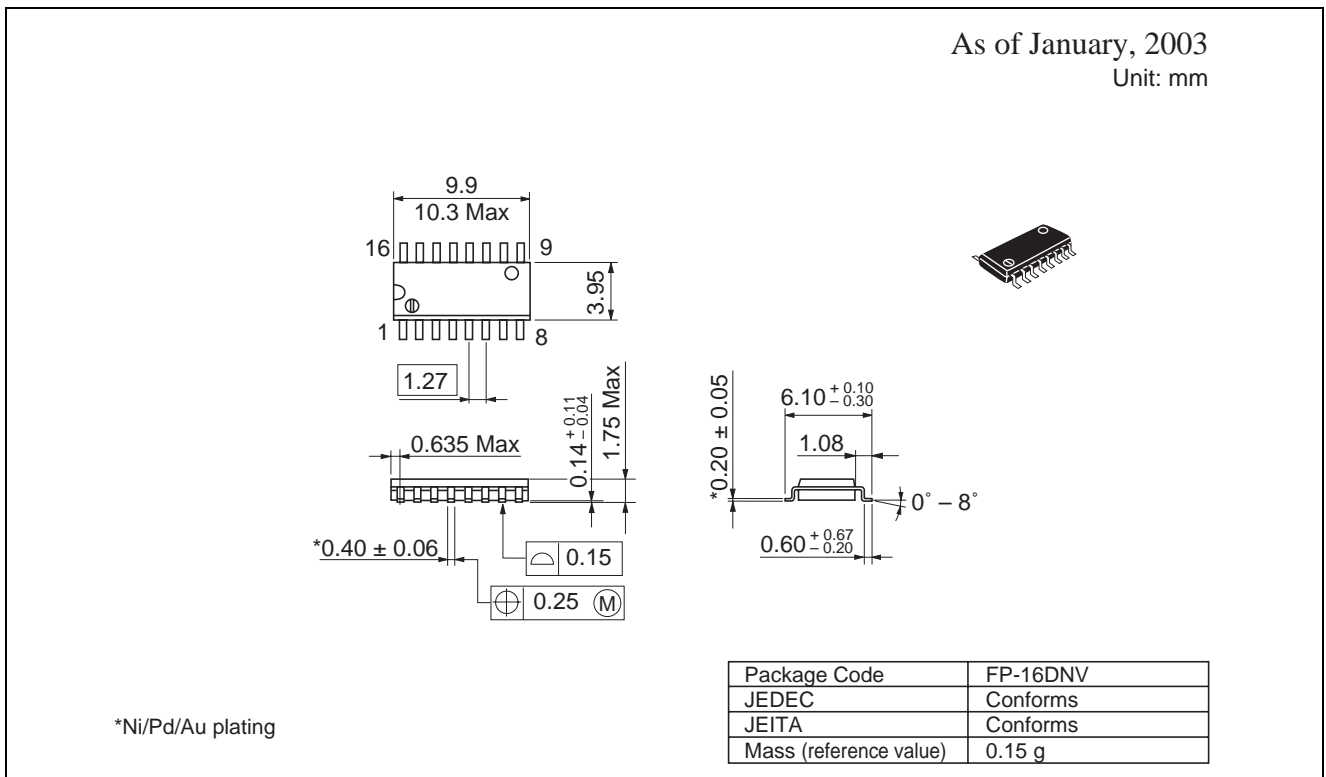
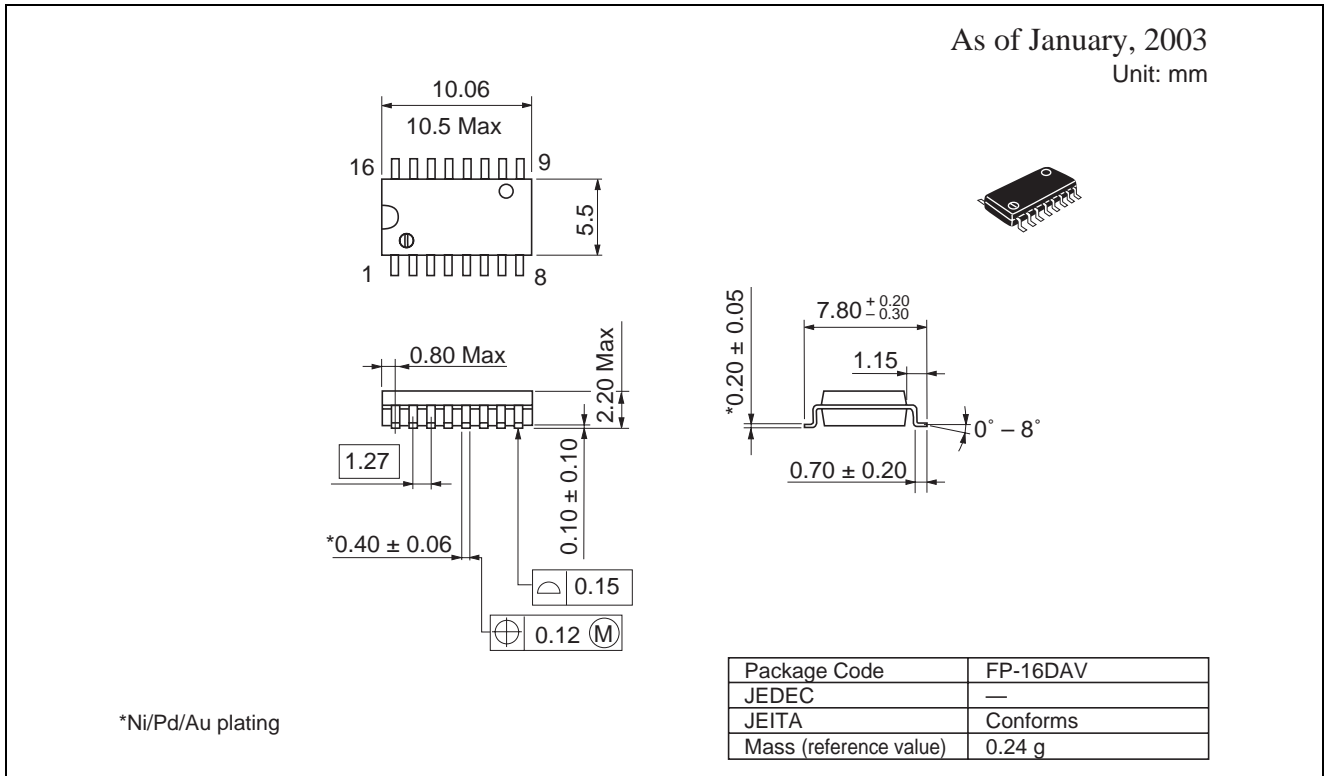

As of January, 2003
Unit: mm

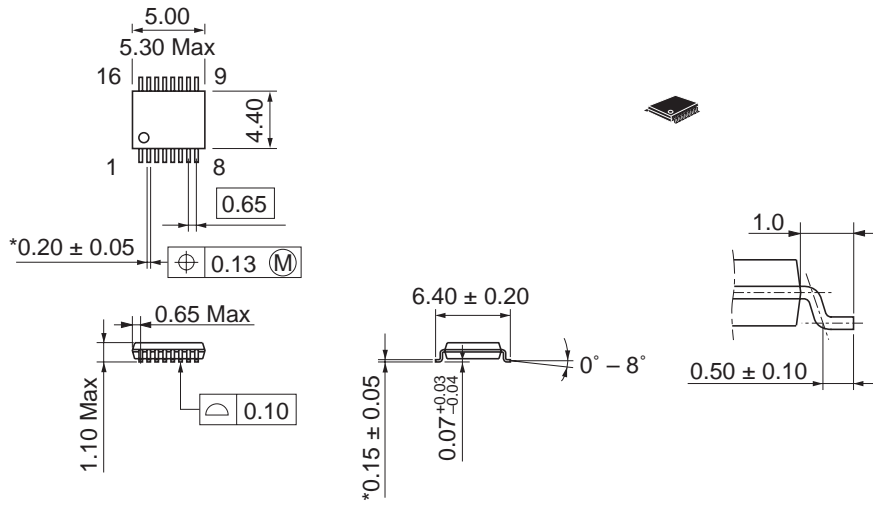

*Ni/Pd/Au plating

Package Code	TTP-16DAV
JEDEC	—
JEITA	—
Mass (reference value)	0.05 g

Renesas Technology Corp. Sales Strategic Planning Div. Nippon Bldg., 2-6-2, Ohte-machi, Chiyoda-ku, Tokyo 100-0004, Japan

Keep safety first in your circuit designs!

1. Renesas Technology Corp. puts the maximum effort into making semiconductor products better and more reliable, but there is always the possibility that trouble may occur with them. Trouble with semiconductors may lead to personal injury, fire or property damage. Remember to give due consideration to safety when making your circuit designs, with appropriate measures such as (i) placement of substitutive, auxiliary circuits, (ii) use of nonflammable material or (iii) prevention against any malfunction or mishap.

Notes regarding these materials

1. These materials are intended as a reference to assist our customers in the selection of the Renesas Technology Corp. product best suited to the customer's application; they do not convey any license under any intellectual property rights, or any other rights, belonging to Renesas Technology Corp. or a third party.
 2. Renesas Technology Corp. assumes no responsibility for any damage, or infringement of any third-party's rights, originating in the use of any product data, diagrams, charts, programs, algorithms, or circuit application examples contained in these materials.
 3. All information contained in these materials, including product data, diagrams, charts, programs and algorithms represents information on products at the time of publication of these materials, and are subject to change by Renesas Technology Corp. without notice due to product improvements or other reasons. It is therefore recommended that customers contact Renesas Technology Corp. or an authorized Renesas Technology Corp. product distributor for the latest product information before purchasing a product listed herein.
The information described here may contain technical inaccuracies or typographical errors.
Renesas Technology Corp. assumes no responsibility for any damage, liability, or other loss rising from these inaccuracies or errors.
Please also pay attention to information published by Renesas Technology Corp. by various means, including the Renesas Technology Corp. Semiconductor home page (<http://www.renesas.com>).
 4. When using any or all of the information contained in these materials, including product data, diagrams, charts, programs, and algorithms, please be sure to evaluate all information as a total system before making a final decision on the applicability of the information and products. Renesas Technology Corp. assumes no responsibility for any damage, liability or other loss resulting from the information contained herein.
 5. Renesas Technology Corp. semiconductors are not designed or manufactured for use in a device or system that is used under circumstances in which human life is potentially at stake. Please contact Renesas Technology Corp. or an authorized Renesas Technology Corp. product distributor when considering the use of a product contained herein for any specific purposes, such as apparatus or systems for transportation, vehicular, medical, aerospace, nuclear, or undersea repeater use.
 6. The prior written approval of Renesas Technology Corp. is necessary to reprint or reproduce in whole or in part these materials.
 7. If these products or technologies are subject to the Japanese export control restrictions, they must be exported under a license from the Japanese government and cannot be imported into a country other than the approved destination.
Any diversion or reexport contrary to the export control laws and regulations of Japan and/or the country of destination is prohibited.
 8. Please contact Renesas Technology Corp. for further details on these materials or the products contained therein.
-



RENESAS SALES OFFICES

<http://www.renesas.com>

Renesas Technology America, Inc.

450 Holger Way, San Jose, CA 95134-1368, U.S.A
Tel: <1> (408) 382-7500 Fax: <1> (408) 382-7501

Renesas Technology Europe Limited.

Dukes Meadow, Millboard Road, Bourne End, Buckinghamshire, SL8 5FH, United Kingdom
Tel: <44> (1628) 585 100, Fax: <44> (1628) 585 900

Renesas Technology Europe GmbH

Dornacher Str. 3, D-85622 Feldkirchen, Germany
Tel: <49> (89) 380 70 0, Fax: <49> (89) 929 30 11

Renesas Technology Hong Kong Ltd.

7/F., North Tower, World Finance Centre, Harbour City, Canton Road, Hong Kong
Tel: <852> 2265-6688, Fax: <852> 2375-6836

Renesas Technology Taiwan Co., Ltd.

FL 10, #99, Fu-Hsing N. Rd., Taipei, Taiwan
Tel: <886> (2) 2715-2888, Fax: <886> (2) 2713-2999

Renesas Technology (Shanghai) Co., Ltd.

26/F., Ruijin Building, No.205 Maoming Road (S), Shanghai 200020, China
Tel: <86> (21) 6472-1001, Fax: <86> (21) 6415-2952

Renesas Technology Singapore Pte. Ltd.

1, Harbour Front Avenue, #06-10, Keppel Bay Tower, Singapore 098632
Tel: <65> 6213-0200, Fax: <65> 6278-8001