

Silicon PNP Power Transistors

2SB633

DESCRIPTION

- With TO-220C package
- Complement to type 2SD613
- High breakdown voltage : $V_{CEO}=-85V$
- High current : $I_C=-6A$

APPLICATIONS

- Recommend for 25-35W high fidelity audio frequency amplifier output stage

PINNING

PIN	DESCRIPTION
1	Emitter
2	Collector;connected to mounting base
3	Base

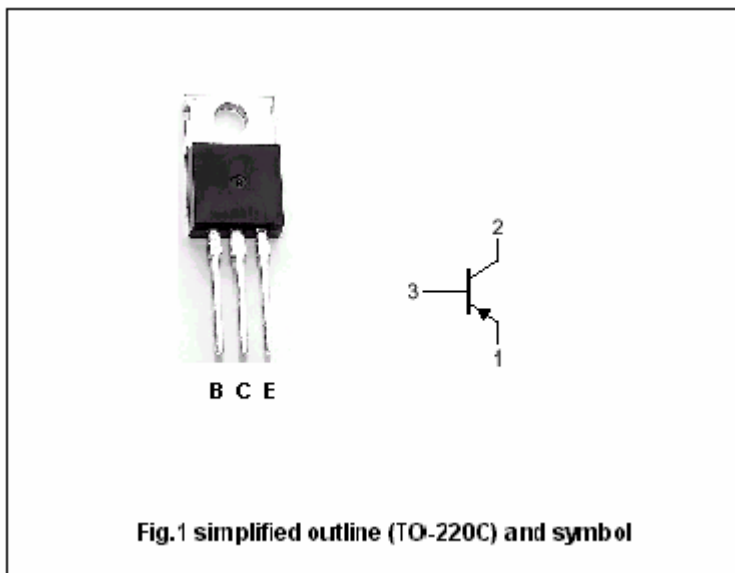

Absolute maximum ratings($T_c=25^\circ$)

SYMBOL	PARAMETER	CONDITIONS	VALUE	UNIT
V_{CBO}	Collector-base voltage	Open emitter	-100	V
V_{CEO}	Collector-emitter voltage	Open base	-85	V
V_{EBO}	Emitter-base voltage	Open collector	-6	V
I_C	Collector current		-6	A
I_{CM}	Collector current-peak		-10	A
P_C	Collector power dissipation	$T_c=25^\circ$	40	W
T_j	Junction temperature		150	$^\circ$
T_{stg}	Storage temperature		-65~150	$^\circ$

Silicon PNP Power Transistors

2SB633

CHARACTERISTICS

T_j=25°C unless otherwise specified

SYMBOL	PARAMETER	CONDITIONS	MIN	TYP.	MAX	UNIT
V _{(BR)CEO}	Collector-emitter breakdown voltage	I _C =-50mA; R _{BE} =∞	-85			V
V _{(BR)CBO}	Collector-base breakdown voltage	I _C =-5mA; I _E =0	-100			V
V _{(BR)EBO}	Emitter-base breakdown voltage	I _E =-5mA; I _C =0	-6			V
V _{CEsat}	Collector-emitter saturation voltage	I _C =-4A; I _B =-0.4 A			-2.0	V
V _{BE}	Base-emitter on voltage	I _C =-1A ; V _{CE} =-5V			-1.5	V
I _{CBO}	Collector cut-off current	V _{CB} =-40V; I _E =0			-0.1	mA
I _{EBO}	Emitter cut-off current	V _{EB} =-4V; I _C =0			-0.1	mA
h _{FE-1}	DC current gain	I _C =-1A ; V _{CE} =-5V	40		320	
h _{FE-2}	DC current gain	I _C =-3A ; V _{CE} =-5V	20			
f _T	Transition frequency	I _C =-1A ; V _{CE} =-5V		15		MHz
C _{OB}	Output capacitance	I _E =0; V _{CB} =-10V; f=1MHz		150		pF

◆ h_{FE-1} classifications

C	D	E	F
40-80	60-120	100-200	160-320

Silicon PNP Power Transistors

2SB633

PACKAGE OUTLINE

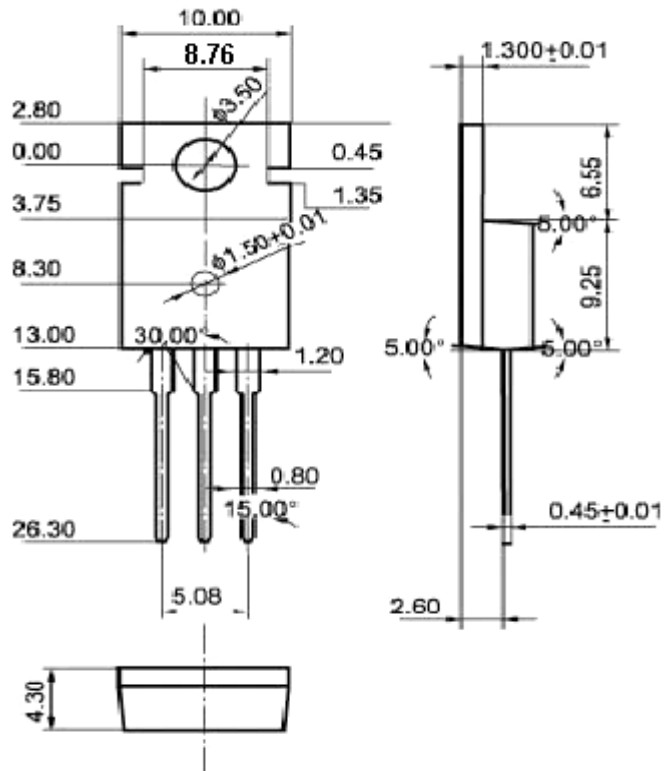

Fig.2 Outline dimensions (unindicated tolerance: ± 0.10 mm)

Silicon PNP Power Transistors

2SB633

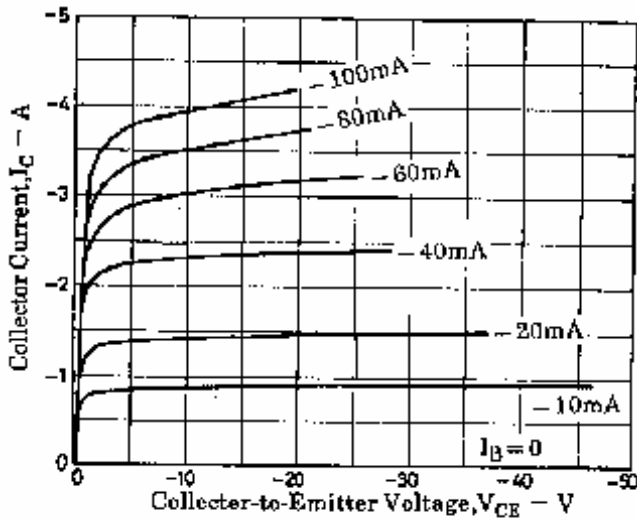

Fig.3 Static Characteristic

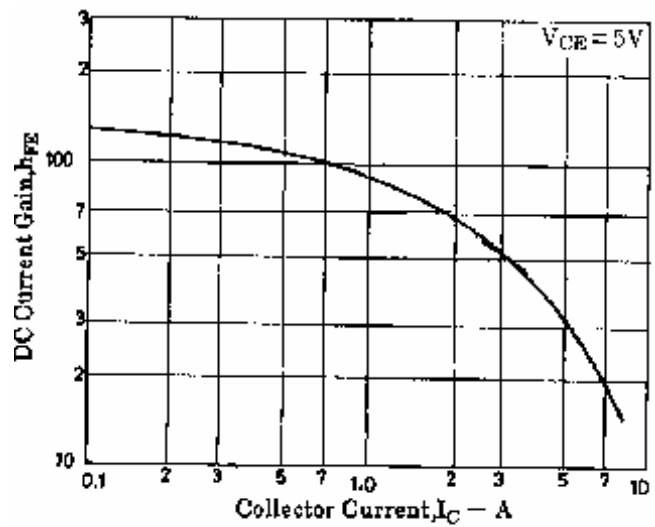

Fig.4 DC current Gain

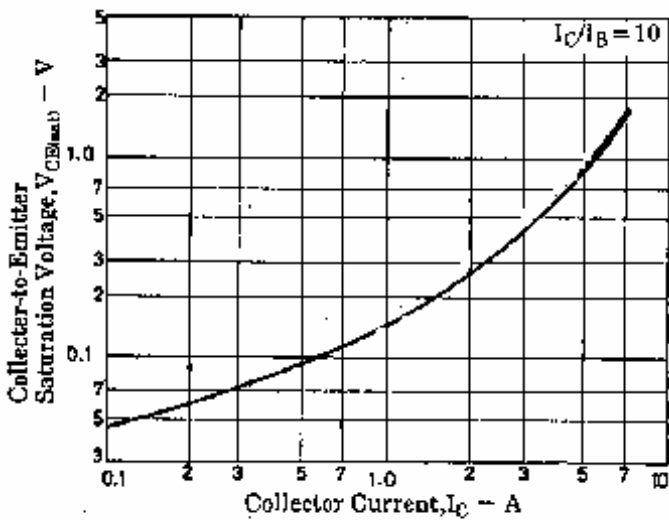

Fig.5 Collector-Emitter Saturation Voltage

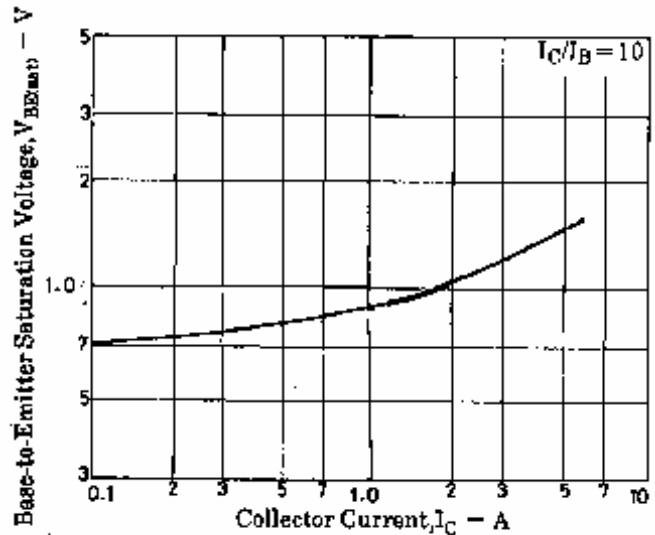

Fig.6 Base-Emitter Saturation Voltage

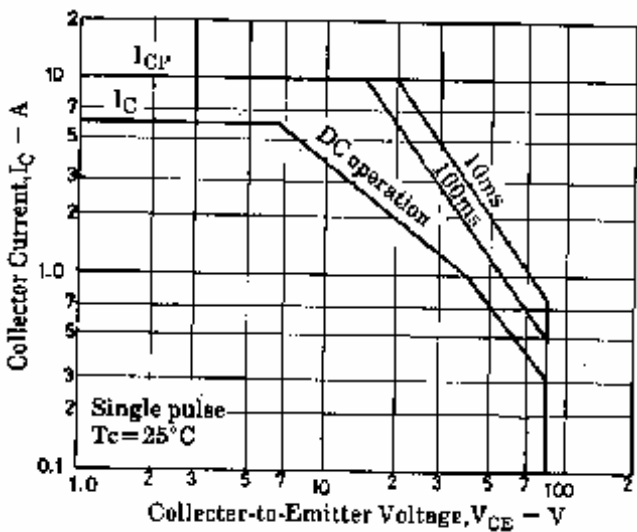

Fig.7 Safe Operating Area