

Silicon NPN Power Transistors

2SC2791

DESCRIPTION

- With TO-3 package
- High collector breakdown voltage
- Excellent switching times

APPLICATIONS

- High speed and high voltage switching
- Switching regulator
- High speed DC-DC converter

PINNING(see Fig.2)

PIN	DESCRIPTION
1	Base
2	Emitter
3	Collector

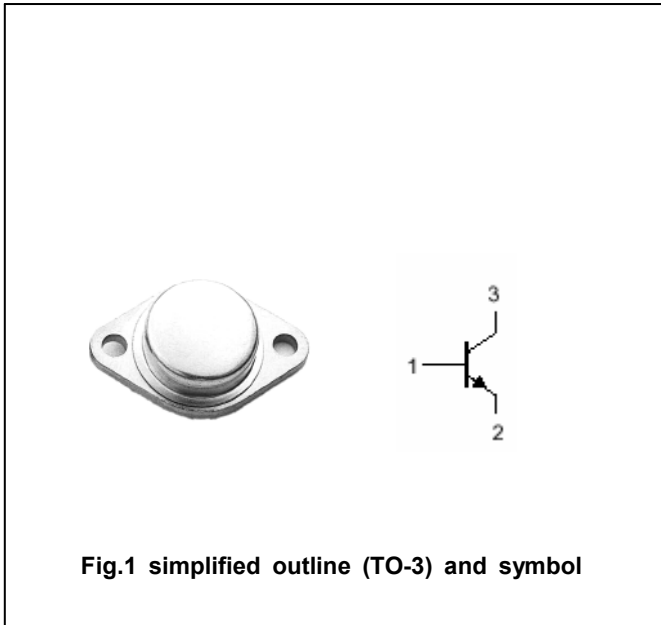

Fig.1 simplified outline (TO-3) and symbol

ABSOLUTE MAXIMUM RATINGS( $T_c=25^\circ C$ )

SYMBOL	PARAMETER	CONDITIONS	VALUE	UNIT
$V_{CBO}$	Collector-base voltage	Open emitter	900	V
$V_{CEO}$	Collector-emitter voltage	Open base	800	V
$V_{EBO}$	Emitter-base voltage	Open collector	7	V
$I_C$	Collector current		5	A
$I_B$	Base current		3	A
$P_C$	Collector power dissipation	$T_c=25^\circ C$	100	W
$T_j$	Junction temperature		150	$^\circ C$
$T_{stg}$	Storage temperature		-55~150	$^\circ C$

## Silicon NPN Power Transistors

## 2SC2791

## CHARACTERISTICS

T<sub>j</sub>=25 °C unless otherwise specified

SYMBOL	PARAMETER	CONDITIONS	MIN	TYP.	MAX	UNIT
V <sub>(BR)CEO</sub>	Collector-emitter breakdown voltage	I <sub>C</sub> =10mA ; I <sub>B</sub> =0	800			V
V <sub>(BR)CBO</sub>	Collector-base breakdown voltage	I <sub>C</sub> =1mA ; I <sub>E</sub> =0	900			V
V <sub>CE(sat)</sub>	Collector-emitter saturation voltage	I <sub>C</sub> =3A; I <sub>B</sub> =0.6A			1.0	V
V <sub>BE(sat)</sub>	Base-emitter saturation voltage	I <sub>C</sub> =3A; I <sub>B</sub> =0.6A			1.5	V
I <sub>CBO</sub>	Collector cut-off current	V <sub>CB</sub> =800V; I <sub>E</sub> =0			100	μA
I <sub>EBO</sub>	Emitter cut-off current	V <sub>EB</sub> =7V; I <sub>C</sub> =0			1	mA
h <sub>FE-1</sub>	DC current gain	I <sub>C</sub> =10mA ; V <sub>CE</sub> =5V	10			
h <sub>FE-2</sub>	DC current gain	I <sub>C</sub> =3A ; V <sub>CE</sub> =5V	10			

## Switching times

t <sub>r</sub>	Rise time	V <sub>CC</sub> =400V , I <sub>C</sub> =3A, I <sub>B1</sub> =0.3A; I <sub>B2</sub> =-0.8A			1.0	μs
t <sub>stg</sub>	Storage time				3.5	μs
t <sub>f</sub>	Fall time				1.0	μs

PACKAGE OUTLINE

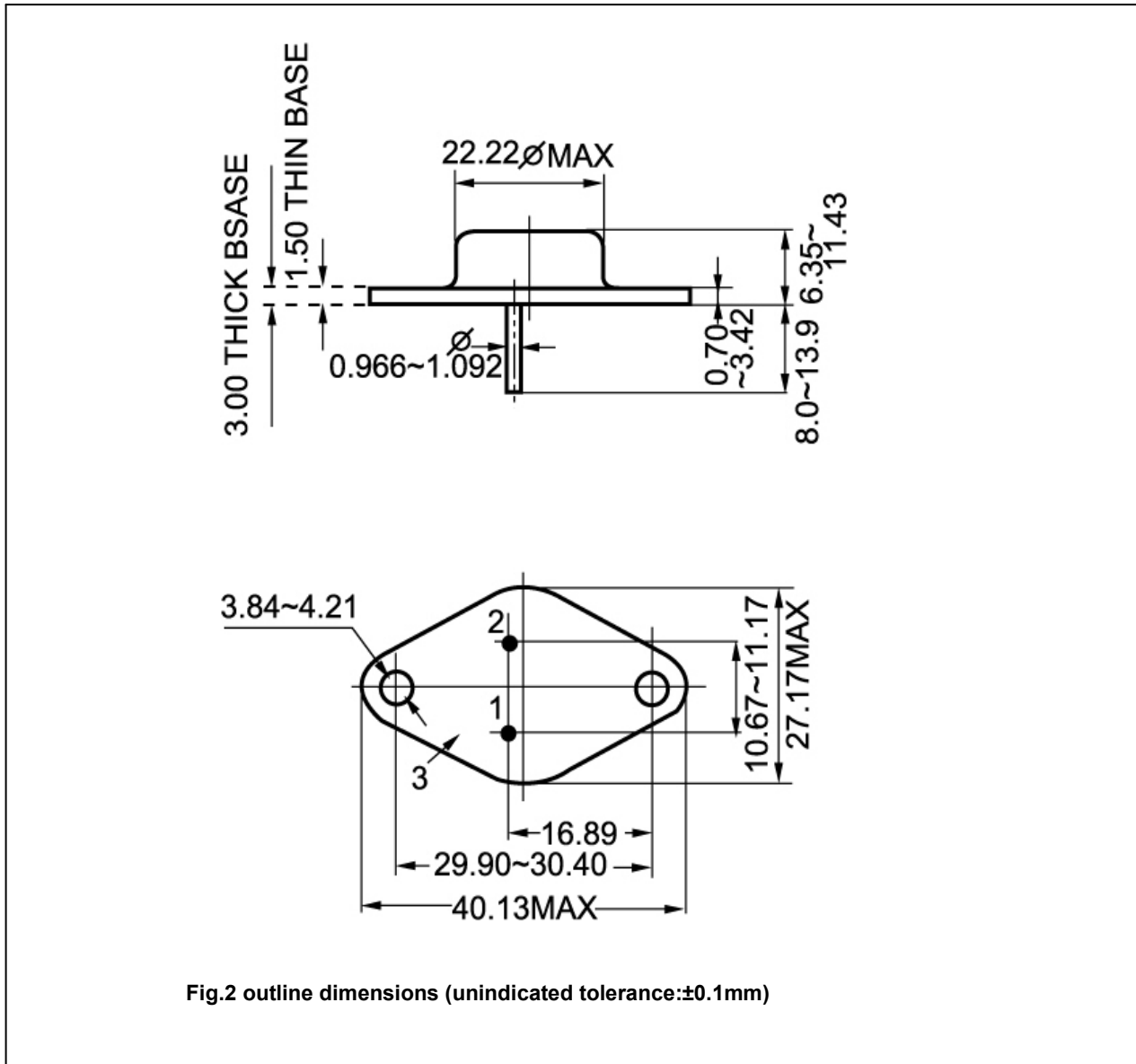

Fig.2 outline dimensions (unindicated tolerance:±0.1mm)