

# CP800 THRU CP808

## SINGLE-PHASE SILICON BRIDGE

VOLTAGE - 50 to 800 Volts CURRENT - P.C. MTG 3A, HEAT-SINK MTG 8A

 Recognized File #E111753

CP-8

### FEATURES

- Surge overload rating—200 Amperes peak
- Low forward voltage drop and reverse leakage
- Small size, simple installation
- Plastic package has Underwriter Laboratory Flammability Classification 94V-O
- Reliable low cost construction utilizing molded plastic technique

### MECHANICAL DATA

Mounting position: Any

Weight: 0.24 ounce, 6.9 grams

Terminals: Leads solderable per MIL-STD-202,  
Method 208

Mounting torque: Thru hole for #6 screw

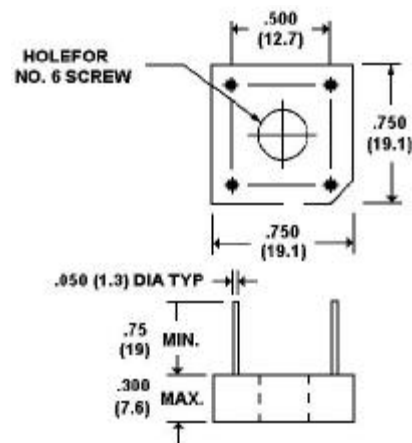

Dimensions in inches and (millimeters)

### MAXIMUM RATINGS AND ELECTRICAL CHARACTERISTICS

At 25 °C ambient temperature unless otherwise noted; resistive or inductive load at 60Hz .

	CP800	CP801	CP802	CP804	CP806	CP808	UNITS	
Max Recurrent Peak Reverse Voltage	50	100	200	400	600	800	V	
Max Bridge Input Voltage RMS	35	70	140	280	420	560	V	
Max Average Rectified Output at $T_C=50\text{ }^{\circ}\text{C}$ *							8.0	A
See Fig. 2 at $T_A=40\text{ }^{\circ}\text{C}$ **							3.0	A
Peak One Cycle Surge Overload Current							200	A
Max Forward Voltage Drop per element at 4.0A DC & 25 °C. See Fig. 3							1.1	V
Max Rev Leakage at rated Dc Blocking Voltage per element at 25 °C							10.0	µg A
See Fig 4 at 100 °C							1.0	mA
I <sup>2</sup> t Rating for fusing ( t < 8.3ms)							166	A <sup>2</sup> Sec
Typical junction capacitance per leg (Note 4) C <sub>J</sub>							200	pF
Typical Thermal Resistance per leg (Note 3) R <sub>θKJA</sub>							21	°C/W
Typical Thermal Resistance per leg (Note 2) R <sub>θKJL</sub>							6	
Operating Temperature Range							-55 TO +125	°C
Storage Temperature Range							-55 TO +150	°C

### NOTES:

1. Bolt down on heat-sink with silicon thermal compound between bridge and mounting surface for maximum heat transfer with #6 screw.
2. Units Mounted on a 8.6" x 8.6" x .24" thick (22 x 22 x 0.6cm) AL plate heatsink.
3. Units Mounted on P.C.B at 0.375" (9.5mm) lead length with 0.5 x 0.5" (12 x 12mm) copper pads.
4. Measured at 1.0MHZ and applied reverse voltage.

# RATING AND CHARACTERISTIC CURVES

CP800 THRU CP808

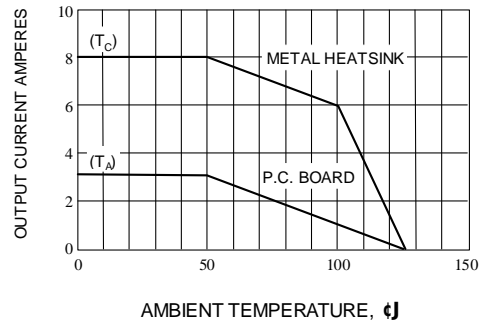
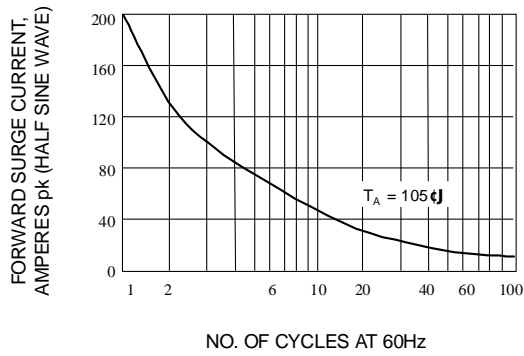

Fig. 2-DERATING CURVE FOR OUTPUT RECTIFIED CURRENT

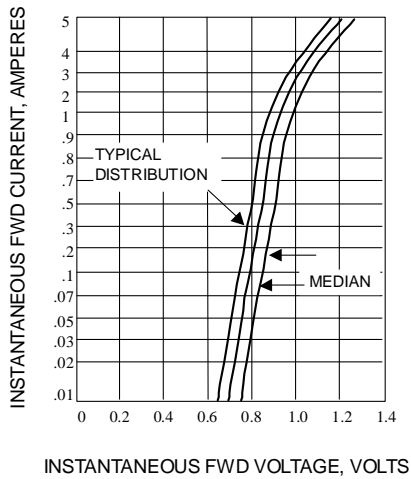

Fig. 3-TYPICAL FORWARD CHARACTERISTICS(25 °C)

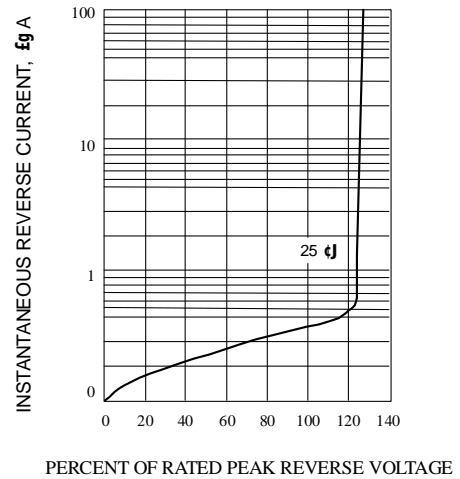

Fig. 4-REVERSE CHARACTERISTICS