



HCA-BARO Series

Miniature amplified barometric pressure sensors

FEATURES

- 600...1100 mbar, 800...1100 mbar barometric ranges
- Output: 0.25...4.25 V and I²C-bus (SPI and switching outputs optional)
- Precision ASIC conditioning
- Calibrated and temperature compensated
- Miniature SMT or SIL housing
- RoHS compliant
- Sensortronics PRO services

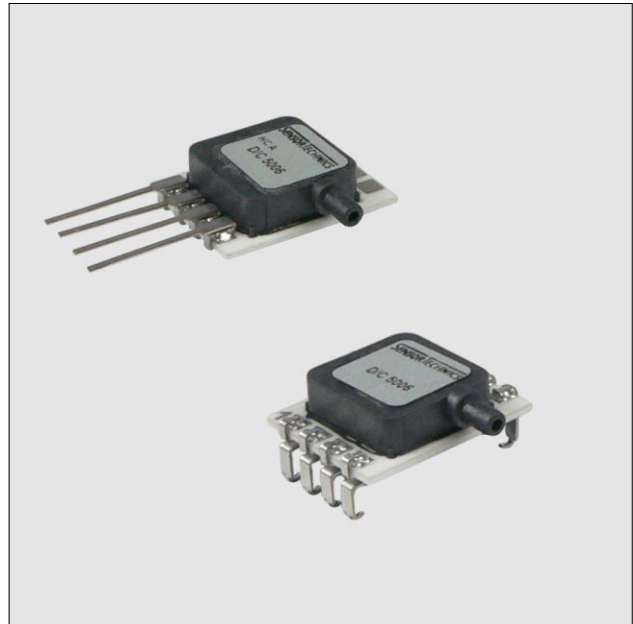

SPECIFICATIONS

Maximum ratings

Supply voltage V_s 4.5 V ... 5.5 V_{DC}
(optional 2.7 ... 3.3 V_{DC})

Output current
Sink 1 mA
Source 1 mA

Proof pressure³ 3000 mbara

Burst pressure⁴ 5000 mbara

Lead specifications

Average preheating temperature gradient 2.5 K/s
Soak time ca. 3 min
Time above 217°C 50 s
Time above 230°C 40 s
Time above 250°C 15 s
Peak temperature 260°C
Cooling temperature gradient -3.5 K/s

Temperature ranges

Compensated 0 ... +85°C
Operating -25 ... +85°C
Storage -40 ... +125°C

Humidity limits (non-condensing) 0 ... 95 %RH

ELECTRICAL CONNECTION

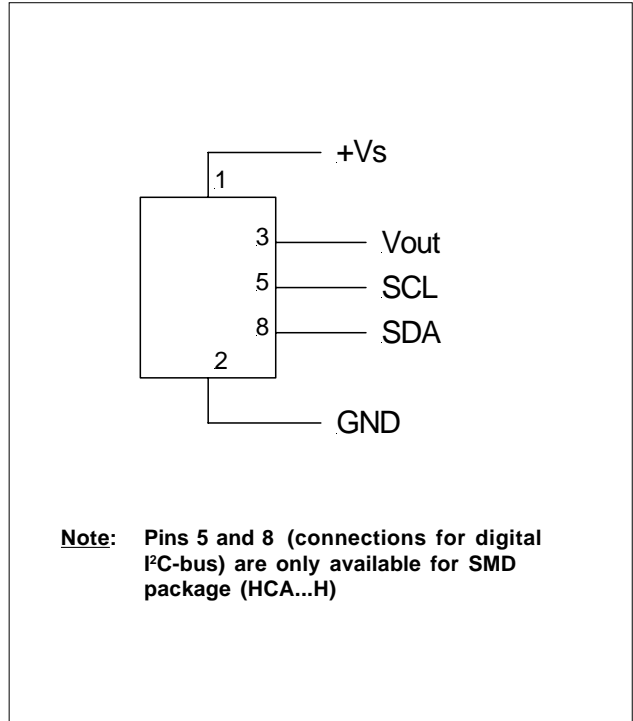



HCA-BARO Series

Miniature amplified barometric pressure sensors

PERFORMANCE CHARACTERISTICS

($V_s = 5.0\text{ V}$, $T_A = 25\text{ °C}$, analog output signal is **ratiometric** to V_s , digital output signal is **not ratiometric** to V_s , pressure applied to high pressure port)

Characteristics		Min.	Typ.	Max.	Unit
Operating pressure range	HCA0611AR...	600		1100	mbara
	HCA0811AR...	800		1100	
Total accuracy (0 ... 85 °C) ¹				±1.0	%FSS
Response delay ^{5,6}			2		ms
A/D resolution ⁶			15		bit
D/A resolution				11	
Current consumption (no load) ⁷			5		mA
DIGITAL PERFORMANCE CHARACTERISTICS					
Output at min. pressure			0666		Count Hex
Full scale span (FSS) ²			6666		
ANALOGUE PERFORMANCE CHARACTERISTICS					
Output at min. pressure			0.25		V
Full scale span (FSS) ²			4.00		

Specification notes:

1. Total accuracy is the combined error from offset and span calibration, linearity, pressure hysteresis, and temperature effects. Linearity is the measured deviation based on a straight line. Hysteresis is the maximum output difference at any point within the operating pressure range for increasing and decreasing pressure. Calibration errors include the deviation of offset and full scale from nominal values.
2. Full Scale Span (FSS) is the algebraic difference between the output signal for the highest and lowest specified pressure.
3. Proof pressure is the maximum pressure which may be applied without causing durable shifts of the electrical parameters of the sensing element.
4. Burst pressure is the maximum pressure which may be applied without causing damage to the sensing element or leaks to the housing.
5. Max. delay time between pressure change at the pressure die and signal change at the output.
6. The response time depends on the adjusted internal A/D resolution of the sensor. For 15 bit it is typ. 2 ms. Other A/D resolutions and response times are available on request. Please contact Sensortronics for further information.
7. Sensors with lower current consumption are available on request. Please contact Sensortronics for further information.



HCA-BARO Series

Miniature amplified barometric pressure sensors

I²C BUS

Introduction

The HCA-BARO is capable to generate a digital output signal. The device runs a cyclic program, which will store a corrected pressure value with 15 bit resolution about every 1 ms within the output registers of the internal ASIC. In order to use the sensor for digital signal readout, it should be connected to a bidirectional I²C-bus.

According to the I²C-bus specification, the bus is controlled by a master device, which generates the clock signal, controls the bus access and generates START and STOP conditions. The HCA-BARO is designed to work as a slave, hence it will only respond to requests from a master device.

Digital I²C interface

The HCA-BARO complies with the following protocol (Fig. 1):

Bus not busy: During idle periods both data line (SDA) and clock line (SCL) remain HIGH.

START condition (S): HIGH to LOW transition of SDA line while clock (SCL) is HIGH is interpreted as START condition. START conditions are always generated by the master. Each initial request for a pressure value has to begin with a START condition.

STOP condition (P): LOW to HIGH transition of SDA line while clock (SCL) is HIGH determines STOP condition. STOP conditions are always generated by the master. More than one request for the current pressure value can be transmitted without generation of intermediate STOP condition.

DATA valid (D): State of data line represents valid data when, after START condition, data line is stable for duration of HIGH period of clock signal. Data on line must be changed during LOW period of clock signal. There is one clock pulse per bit of data.

Acknowledge (A): Data is transferred in pieces of 8 bits (1 byte) on serial bus, MSB first. After each byte receiving device – whether master or slave – is obliged to pull data line LOW as acknowledge for reception of data. Master must generate an extra clock pulse for this purpose. When acknowledge is missed, slave transmitter becomes inactive. It is on master either to send last command again or to generate STOP condition in that case.

Slave address: The I²C-bus master-slave concept requires a unique address for each device. The HCA-BARO has a preconfigured slave address (1111000xb). By factory programming it is possible to define a secondary slave address additional to the general one. According to I²C specification 127 different addresses are available. The sensor will then listen to both slave addresses. After generating a START condition the master sends the address byte containing a 7 bit address followed by a data direction bit (R/W). A "0" indicates a transmission from master to slave (WRITE), a "1" indicates a data request (READ).

DATA operation: The HCA-BARO starts to send 2 data bytes containing the current pressure value as a 15 bit information placed in the output registers.

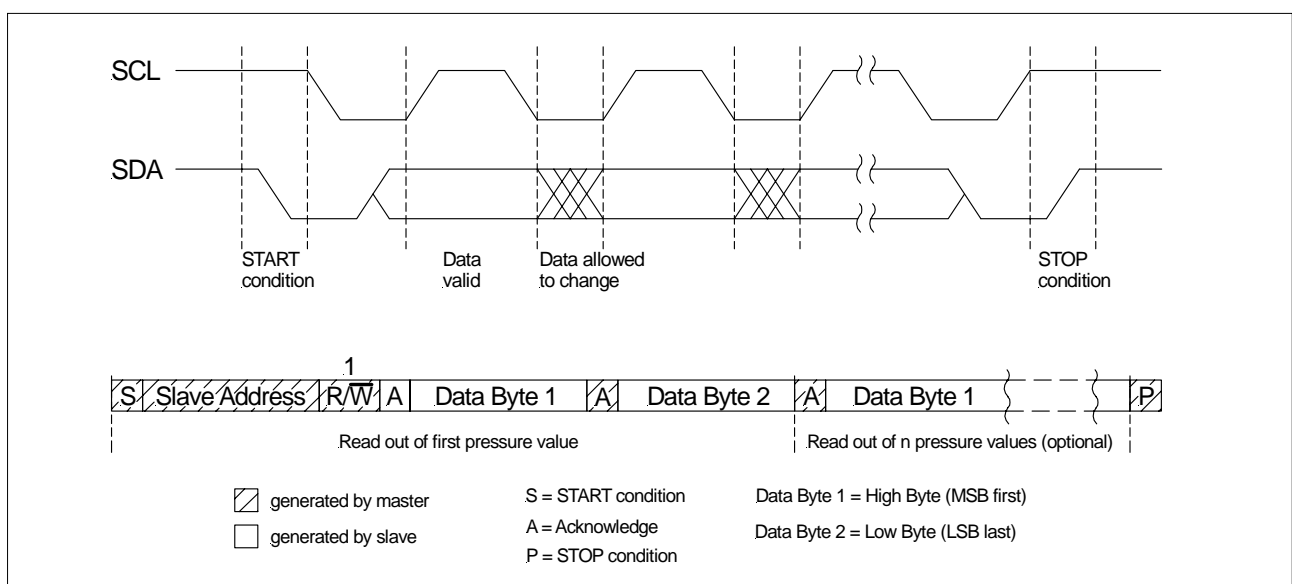

Fig. 1: I²C bus protocol



HCA-BARO Series

Miniature amplified barometric pressure sensors

I²C Interface Parameters

Parameter	Symbol	Min.	Typ.	Max.	Unit
Input high level		90		100	% of V _s
Input low level		0		10	
Output low level				10	
Pull-up resistor		500			Ω
Load capacitance @ SDA	C _{SDA}			400	pF
Input capacitance @ SDA/SCL	C _{I2C IN}			10	
SCL clock frequency	F _{SCL}	100*		400	kHz
Bus free time between STOP and START condition	t _{BUF}	1.3			μs
Hold time (repeated) START condition, to first clock pulse	t _{HD,STA}	0.8			
LOW period of SCL	t _{LOW}	1.3			
HIGH period of SCL	t _{HIGH}	0.6			
Setup time repeated START condition	t _{SU,STA}	1			
Data hold time	t _{HD,DAT}	0			
Data setup time	t _{SU,DAT}	0.2			
Rise time of both SDA and SCL	t _R			0.3	
Fall time of both SDA and SCL	t _F			0.3	
Setup time for STOP condition	t _{SU,STO}	0.6			

* recommended

Note: Sensortronics recommends communication speeds of at least 100 kHz (max. 400 kHz). Please contact your nearest Sensortronics sales office for further information.

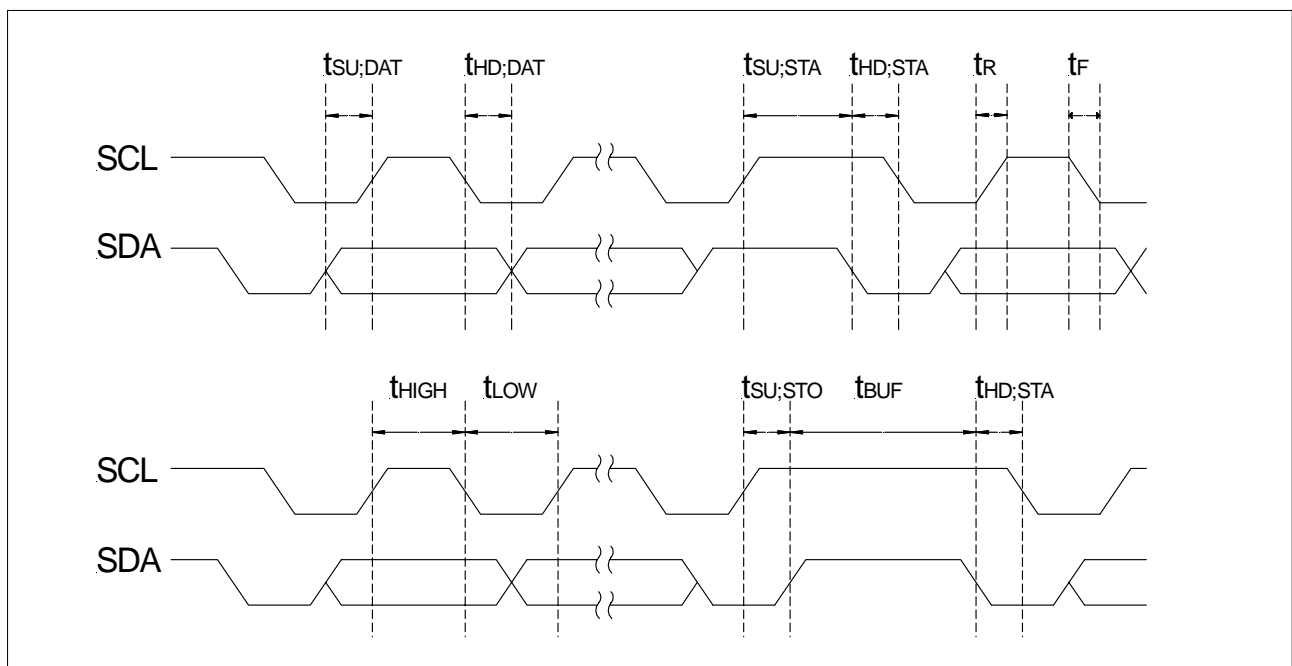

Fig. 2: Timing characteristics



HCA-BARO Series

Miniature amplified barometric pressure sensors

PHYSICAL DIMENSIONS AND ELECTRICAL CONNECTIONS

HCA...G8 Single port

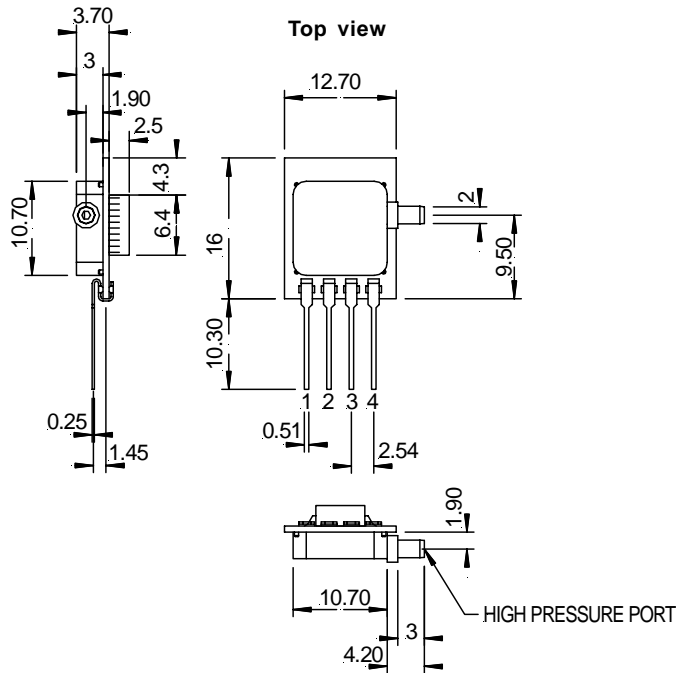

Pin	Connection
1	+Vs
2	GND
3	Vout
4	I / C*

* Internal connection.
Do not connect for any reason

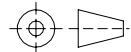

third angle projection

dimensions in mm

HCA...H8 SMD single port

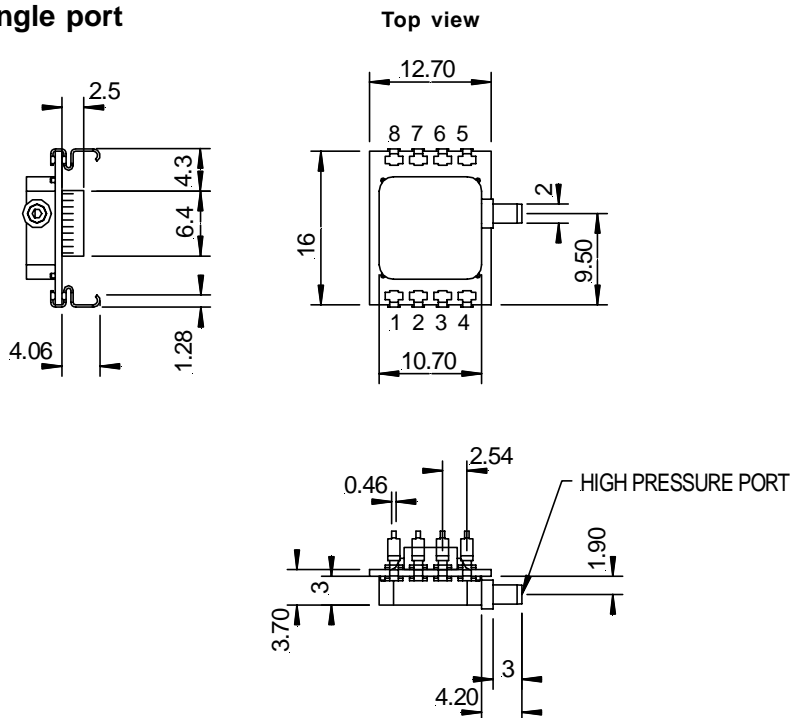

Pin	Connection
1	+Vs
2	GND
3	Vout
4	I / C *
5	SCL
6	I / C *
7	
8	SDA

* Internal connection.
Do not connect for any reason

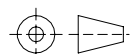

third angle projection

dimensions in mm



HCA-BARO Series

Miniature amplified barometric pressure sensors

ORDERING INFORMATION

Options	Series	Pressure range		Pressure mode		Calibration		Housing		Porting		
		HCA	0611	600...1100 mbar	A	Absolute	R	Barometric	G*	SIL	8	Straight
		0811	800...1100 mbar					H	SMD	9	Barbed	
									* not available with digital output			
Example:	HCA	0611		A		R		H		8		

Custom specific mechanical or electronic sensor modifications are widely available:

- 3 V power supply
- SPI, switching and custom specific outputs
- Dual inline packages (DIP)
- ... etc.

Please contact your nearest Sensortechincs sales office for further information.

Sensortechincs PRO services:

- Extended guarantee period of 2 years
- Custom product modifications and adaptations even for small quantities
- Advanced logistics models for supply inventory and short delivery times
- Technical support through application engineers on the phone or at your site
- Traceability of each sensor through serial numbers on request
- No product specification changes without customer notification
- No product obsolescence without very early prior notice
- Fastest possible technical response for design and QA engineers
- Long term product availability for your spares and service needs
- ... plus other services on request

Sensortechincs reserve the right to make changes to any products herein. Sensortechincs do not assume any liability arising out of the application or use of any product or circuit described herein, neither does it convey any license under its patent rights nor the rights of others.