



DC PIR CONTROLLER

GENERAL DESCRIPTION

The M7616 is a low power PIR (passive infra-red) controller LSI designed for battery powered can be used in many application. The chip contains operation amplifiers, comparators, timer ,a voltage regulator, 2 oscillator and control circuits. An CDS device is installed externally to cut off the operation of M7616 during the day time.

FEATURES

- High noise immunity.
- Low stand-by current < 50 μ A @3.0V
- RELAY Driver only.
- Adjustable play on duration and latch duration.
- CDS input conditionally.
- 16 pin DIP or SOP package.

APPLICATIONS

- PIR light controller, Motion Detector, Alarm system, Auto-door bell.

PIN DESCRIPTION

PIN	Pin Name	I/O	Description
1	RETG	I	Trigger type selection VDD : Retrigger ; VSS : Non-Retrigger
2	Relay	O	Relay driver output through external NPN transistor. Active high.
3,4	RR1/ RC1	—	Delay timing oscillator connect to external RC to adjust output active duration when triggered. output active duration $T_x \approx 110000 \times R10 \times C6$ °
5,6	RC2/ RR2	—	Trigger latch timing oscillator connect to external RC to adjust latch active duration when triggered. latch active duration $T_i \approx 110 \times R9 \times C7$ °
7	VSS	—	Negative power supply
8	RESET	I	Normally connect to VDD, connect to VSS to reset Timer .
9	CDS	I	Connect to the CDS voltage divider for daytime/night auto detecting,. When $V_{cds} < VR$ daytime ; When $V_{cds} > VR$ night ($VR \approx 0.2VDD$)
11	VDD	—	Positive power supply
12	2OUT	O	2 nd Stage Operation amplifier output
13	2IN-	I	2 nd Stage Operation amplifier negative input
14	1IN+	I	First Stage Operation amplifier positive input
15	1IN-	I	First Stage Operation amplifier negative input
16	1OUT	O	First Stage Operation amplifier output

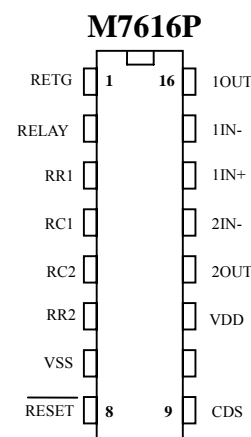



DC PIR CONTROLLER

BLOCK DIAGRAM

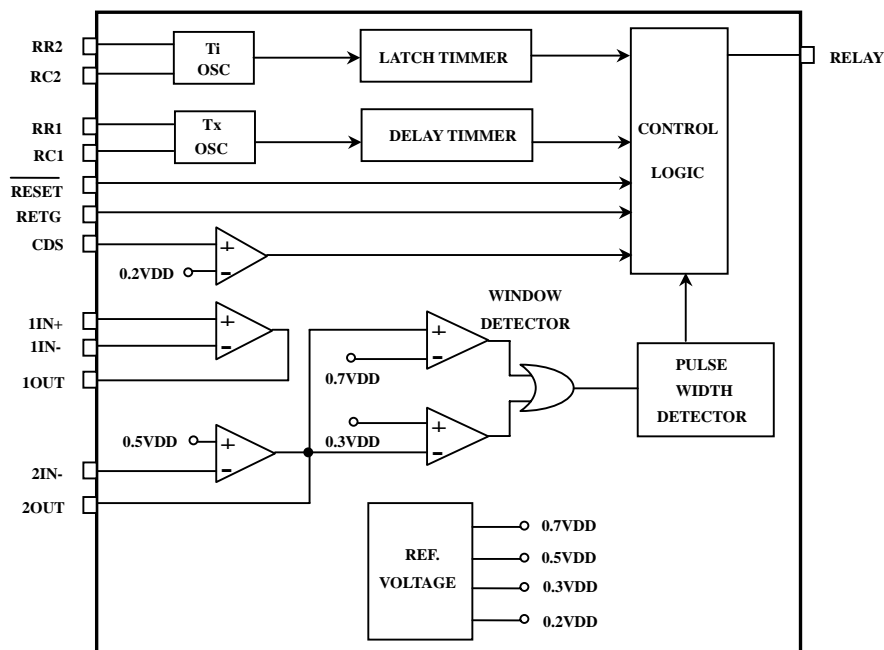

ABSOLUTE MAXIMUM RATING

(TA=25°C)

Parameter	Sym.	Rating	Unit
Power Supply V_{DD} With Respect to V_{SS}	$V_{DD} - V_{SS}$	6	V
Voltage On Any Pin		-0.3 to 6	V
Operating Temperature	Top	-20 to 70	°C
Storage Temperature		-65 to 150	°C

ELECTRICAL CHARACTERISTICS

(TA=25°C)

Characteristics	Sym.	Min.	Typ.	Max.	Unit	Conditions
Supply Voltage	V_{DD}	2.0	4.5	5.5	V	
Operating Current	I_{DD}	—	—	50	μA	No load @3.0 volt
		—	—	70		No load @5.0 volt
“H” Transfer Voltage	V_{IH}	—	$0.7 V_{DD}$	—	V	
“L” Transfer Voltage	V_{IL}	—	$0.3 V_{DD}$	$0.3 V_{DD}$	V	
OP Amp Open Loop Gain	A_{VO}	60	80	—	dB	No load
OP Amp Input Offset Voltage	V_{OS}	—	10	35	mV	No load
CDS “H” Transfer Voltage	V_{cds+}	—	$0.2V_{DD}$	—	V	
Relay Source Current	I_{RS}	—	—	10	mA	



DC PIR CONTROLLER

NON-RETRIGGER (RETG=VSS)

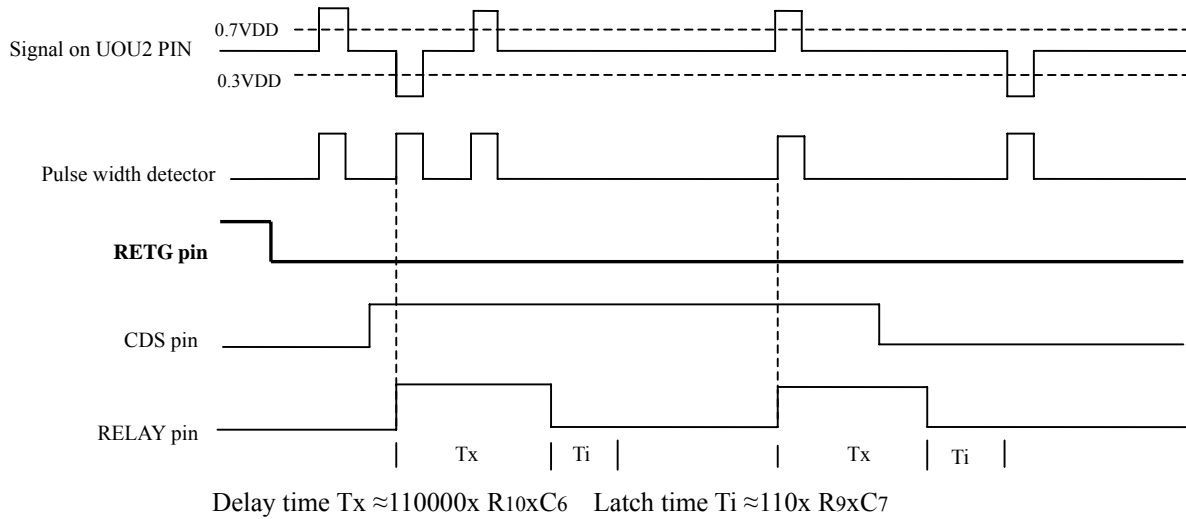

RETRIGGER (TRTG=VDD)

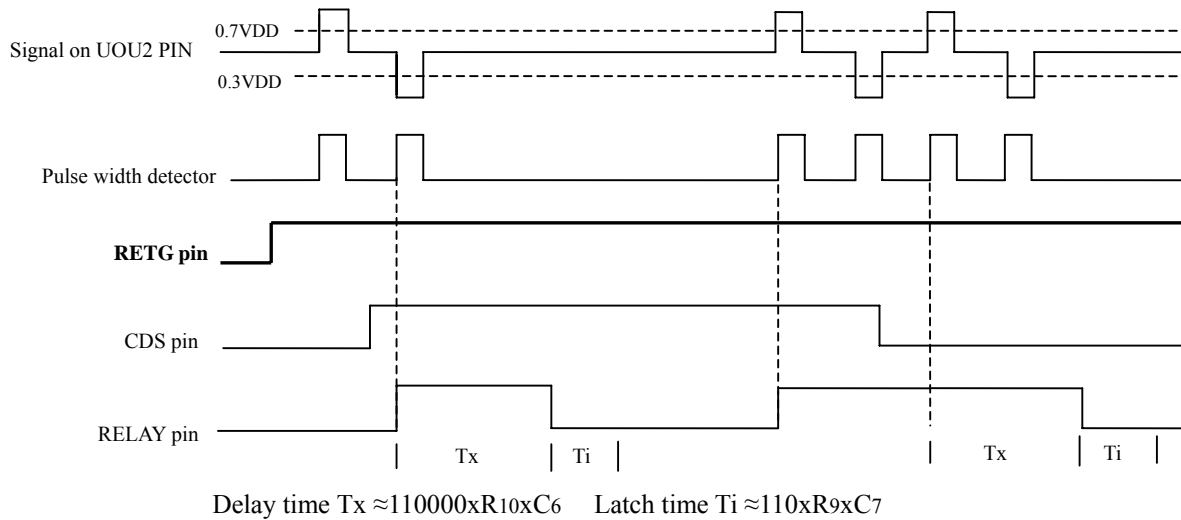



DC PIR CONTROLLER

APPLICATION DIAGRAM

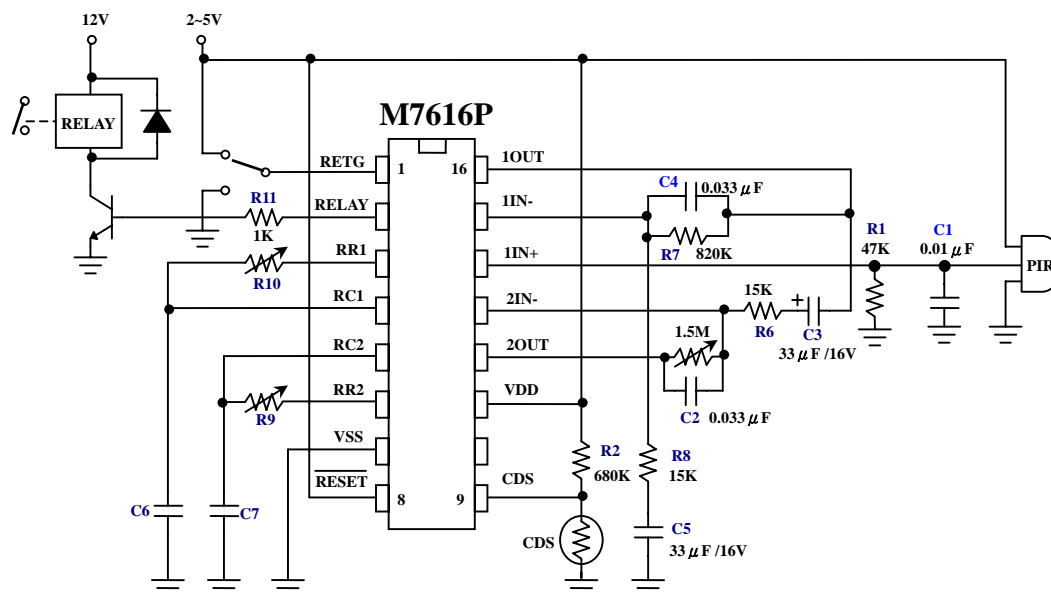

Delay Time

C6=100pF			R10=360KΩ		
R10	F _{TX}	T _X	C6	F _{TX}	T _X
820 KΩ	5.8 KHz	9 sec	250 pF	5.6 KHz	9 sec
750 KΩ	6.3 KHz	8 sec	200 pF	6.3 KHz	8 sec
680 KΩ	6.8 KHz	7.5 sec	180 pF	7.2 KHz	7 sec
560 KΩ	8.3 KHz	6 sec	150 pF	8.4 KHz	6 sec
430 KΩ	10.6 KHz	5 sec	120 pF	10.2 KHz	5 sec
300 KΩ	15.4 KHz	3.5 sec	82 pF	14.7 KHz	4 sec
270 KΩ	16.9 KHz	3 sec	68 pF	17.9 KHz	3 sec
180 KΩ	25.0 KHz	2 sec	47 pF	25.8 KHz	2 sec
100 KΩ	48.8 KHz	1.5 sec	33 pF	37.3 KHz	1.5 sec

Latch Time

C7=0.1uF		
R9	F _{TI}	T _I
820 KΩ	6 Hz	9 sec
750 KΩ	6.4 Hz	7.5 sec
680 KΩ	6.8 Hz	6 sec
560 KΩ	8.4 Hz	5 sec
430 KΩ	11.1 Hz	4 sec
270 KΩ	17.8 Hz	2 sec

* All specs and applications shown above subject to change without prior notice.
(以上電路及規格僅供參考,本公司得逕行修正)