

SIEMENS



C505A
C505CA

8-Bit CMOS Microcontroller

Addendum to C505/C505C User's Manual 09.97

[http://www.siemens.de/
Semiconductor/](http://www.siemens.de/Semiconductor/)

Edition 09.97

This edition was realized using the software system FrameMaker®.

**Published by Siemens AG,
Bereich Halbleiter, Marketing-
Kommunikation, Balanstraße 73,
81541 München**

© Siemens AG 97.
All Rights Reserved.

Attention please!

As far as patents or other rights of third parties are concerned, liability is only assumed for components, not for applications, processes and circuits implemented within components or assemblies.

The information describes the type of component and shall not be considered as assured characteristics.

Terms of delivery and rights to change design reserved.

For questions on technology, delivery and prices please contact the Semiconductor Group Offices in Germany or the Siemens Companies and Representatives worldwide (see address list).

Due to technical requirements components may contain dangerous substances. For information on the types in question please contact your nearest Siemens Office, Semiconductor Group.

Siemens AG is an approved CECC manufacturer.

Packing

Please use the recycling operators known to you. We can also help you – get in touch with your nearest sales office. By agreement we will take packing material back, if it is sorted. You must bear the costs of transport.

For packing material that is returned to us unsorted or which we are not obliged to accept, we shall have to invoice you for any costs incurred.

Components used in life-support devices or systems must be expressly authorized for such purpose!

Critical components¹ of the Semiconductor Group of Siemens AG, may only be used in life-support devices or systems² with the express written approval of the Semiconductor Group of Siemens AG.

- 1 A critical component is a component used in a life-support device or system whose failure can reasonably be expected to cause the failure of that life-support device or system, or to affect its safety or effectiveness of that device or system.
- 2 Life support devices or systems are intended (a) to be implanted in the human body, or (b) to support and/or maintain and sustain human life. If they fail, it is reasonable to assume that the health of the user may be endangered.

Contents	Page
1 Introduction	1-1
1.1 Pin Configuration	1-4
1.2 Pin Definitions and Functions	1-5
2 Memory Organization	2-1
2.1 Program Memory, "Code Space"	2-2
2.2 Data Memory, "Data Space"	2-2
2.3 General Purpose Registers	2-2
2.4 Special Function Registers	2-3
3 A/D Converter	3-1
3.1 A/D Converter Operation	3-1
3.2 A/D Converter Registers	3-3
3.3 A/D Converter Clock Selection	3-7
3.4 A/D Conversion Timing	3-8
3.5 A/D Converter Calibration	3-12
3.5.1 A/D Converter Analog Input Selection	3-13
4 OTP Memory Operation	4-1
4.1 Programming Configuration	4-1
4.2 Pin Configuration	4-2
4.3 Pin Definitions	4-3
4.4 Programming Mode Selection	4-5
4.4.1 Basic Programming Mode Selection	4-5
4.4.2 OTP Memory Access Mode Selection	4-6
4.5 Program / Read OTP Memory Bytes	4-7
4.6 Lock Bits Programming / Read	4-9
4.6.1 Access of Version Bytes	4-11
4.7 OTP Verification Mode	4-12
5 Device Specifications	5-1
5.1 Absolute Maximum Ratings	5-1
5.2 DC Characteristics	5-2
5.3 A/D Converter Characteristics	5-5
5.4 AC Characteristics (12 MHz, 0.5 Duty Cycle)	5-7
5.5 AC Characteristics (16 MHz, 0.4 to 0.6 Duty Cycle)	5-9
5.6 AC Characteristics (20 MHz, 0.5 Duty Cycle)	5-12
5.7 OTP Memory Characteristics	5-17
5.7.1 Programming Mode Timing Characteristics	5-17
5.7.2 OTP Verification Mode Characteristics	5-21
5.8 Package Information	5-23
6 Index	6-1

1 Introduction

The C505A is an enhanced, upgraded version of the C505-2R eight bit microcontroller and incorporates more on-chip RAM, a 10-bit A/D Converter and 32K bytes of on-chip OTP memory. With a maximum external clock rate of 20 MHz, the C505A has an instruction cycle time of 300 ns.

With the C505A-4E fast OTP programming cycles are achieved (1 byte in 100 μsec). Also several levels of OTP memory protection can be selected. The basic functionality of the C505A-4E as a microcontroller is identical to the C505A-L (romless part) functionality. Therefore, the programmable C505A-4E typically can be used for prototype system design.

The C505A-4E basically operates with internal OTP and/or external program memory. The C505A-L is identical to the C505A-4E, except that it lacks the on-chip OTP memory. Therefore, in this documentation the term C505A refers to all versions within this specification unless otherwise noted.

The C505CA-4E and C505CA-L, are identical to the C505A-4E and the C505A-L respectively, except that they have, in addition, the full CAN interface. The term C505A refers to all the above four versions within this documentation unless otherwise noted.

Figure 1-1 shows the different functional units of the C505A and Figure 1-2 shows the simplified logic symbol of the C505A.

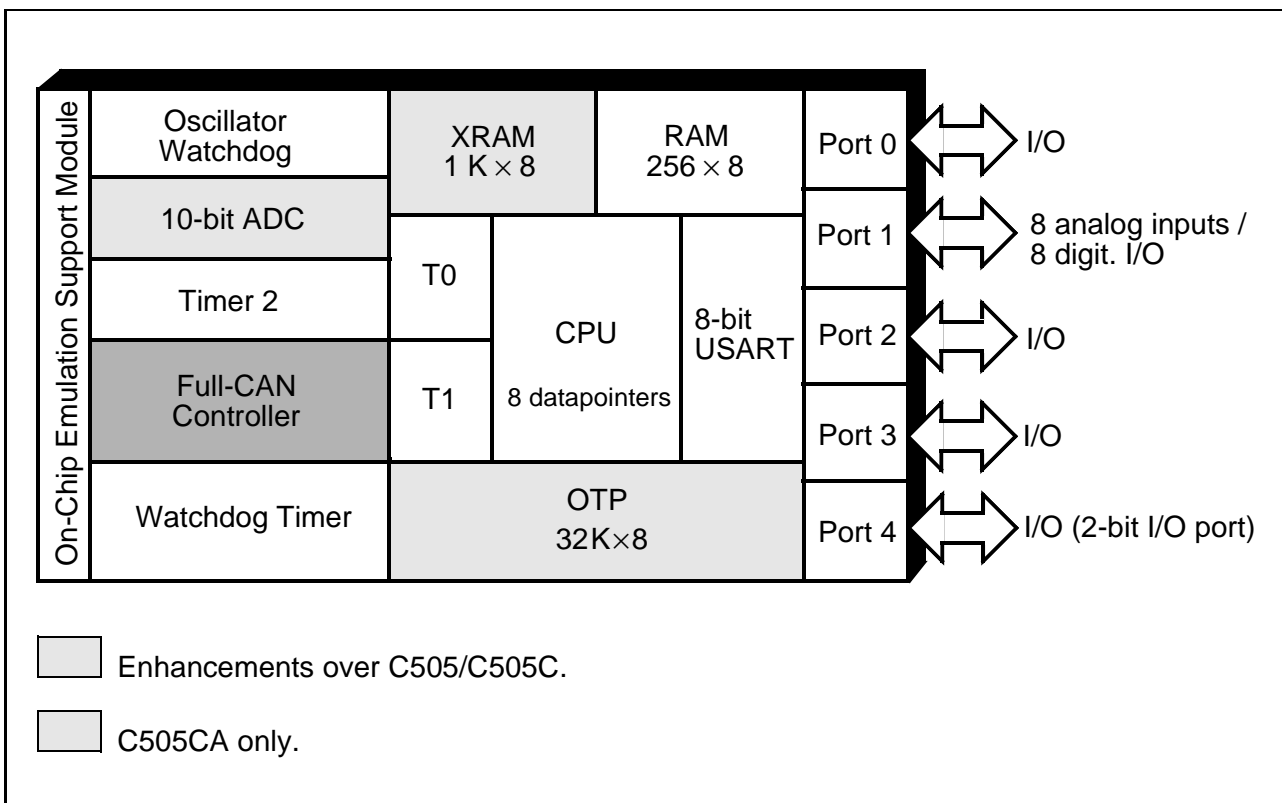

Figure 1-1
C505A Functional Units

Note: This specification describes only the improved functionality over C505/C505C. Please refer to the C505/C505C User's Manual for further details.

Listed below is a summary of the main features of the C505A family:

- Fully compatible to standard 8051 microcontroller
- Superset of the 8051 architecture with 8 datapointers
- Up to 20 MHz operating frequency
 - 375 ns instruction cycle time @ 16 MHz
 - 300 ns instruction cycle time @ 20 MHz (50 % duty cycle)
- 32K byte on-chip OTP memory
 - C505A-4E : programmable OTP versions
 - C505A-L : without on-chip program memory
 - alternatively up to 64 K bytes of external program memory
- 256 byte on-chip RAM
- 1 K byte on-chip XRAM
- Five ports: 32 + 2 digital I/O lines (Port 1 with mixed analog/digital I/O capability)
- Three 16-bit timers/counters
 - Timer 0 / 1 (C501 compatible)
 - Timer 2 with 4 channels for 16-bit capture/compare operation
- Full CAN Module (C505CA only)
 - 256 register/data bytes located in external data memory area
 - 1 MBaud CAN baudrate when operating frequency is equal to or above 8 MHz
 - internal CAN clock prescaler when input frequency is over 10 MHz
- Full duplex serial interface with programmable baudrate generator (USART)
- 10-bit A/D Converter with 8 multiplexed inputs
 - Built-in self calibration
- Twelve interrupt sources with four priority levels
- On-chip emulation support logic
 - Enhanced Hooks Technology™¹⁾
- Programmable 15-bit Watchdog Timer
- Oscillator Watchdog
- Fast Power On Reset
- Power Saving Modes
 - Slow-down mode
 - Idle mode (can be combined with slow-down mode)
 - Software power-down mode with wake up capability through P3.2/ $\overline{INT0}$ or P4.1/RXDC pin
- P-MQFP-44 package
- Pin configuration is compatible to C501, C504, C511/C513-family, C505, C505C
- Temperature ranges:

SAB-C505A versions	$T_A = 0$ to 70 °C
SAF-C505A versions	$T_A = -40$ to 85 °C
SAH-C505A versions	$T_A = -40$ to 110 °C (max. operating frequency: TBD)
SAK-C505A versions	$T_A = -40$ to 125 °C (max. operating frequency: 12 MHz with 50 % duty cycle)

1 “Enhanced Hooks Technology“ is a trademark and patent of Metalink Corporation licensed to Siemens.

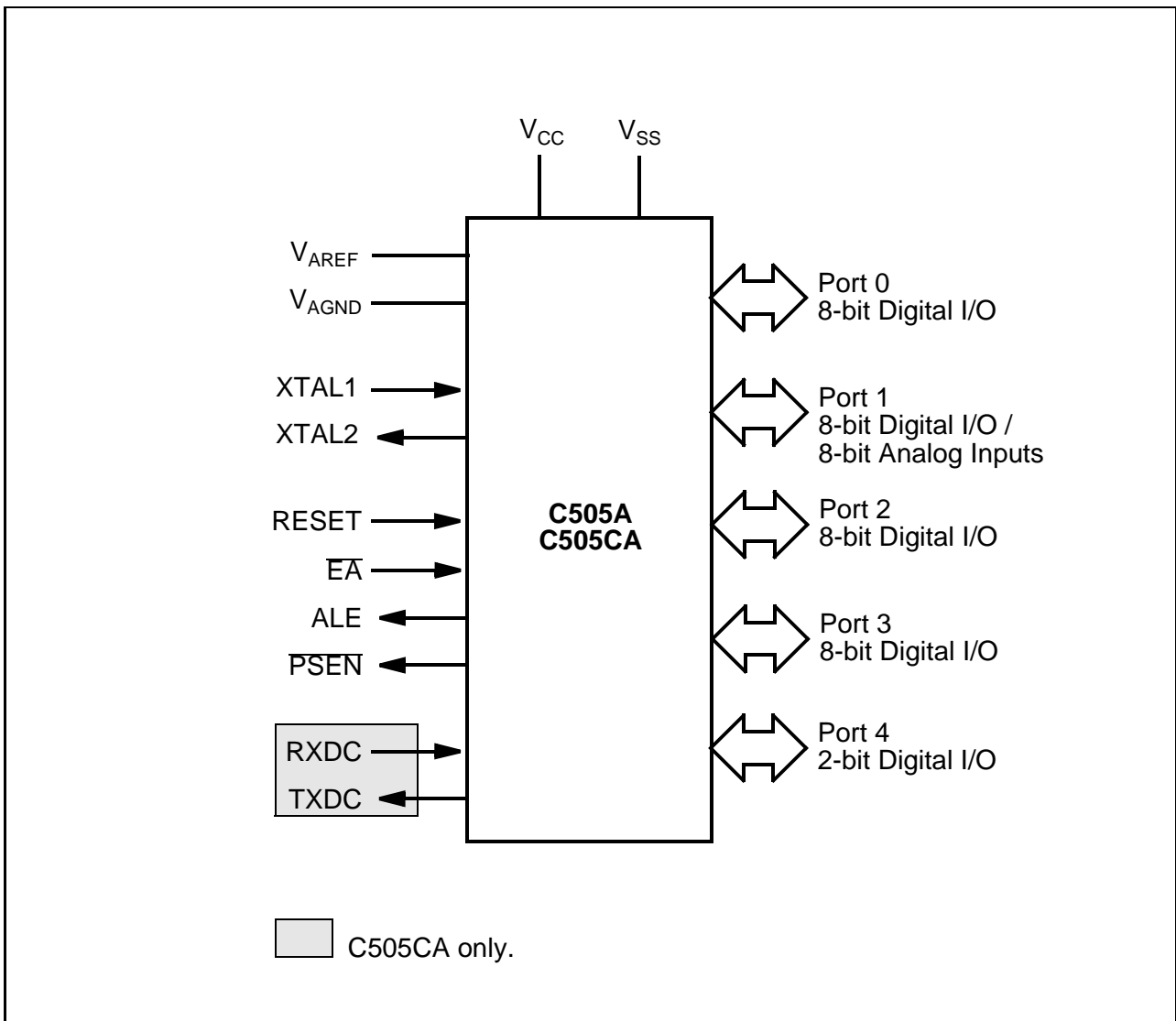

Figure 1-2
Logic Symbol

1.1 Pin Configuration

This section shows the pin configuration of the C505A in the P-MQFP-44 package.

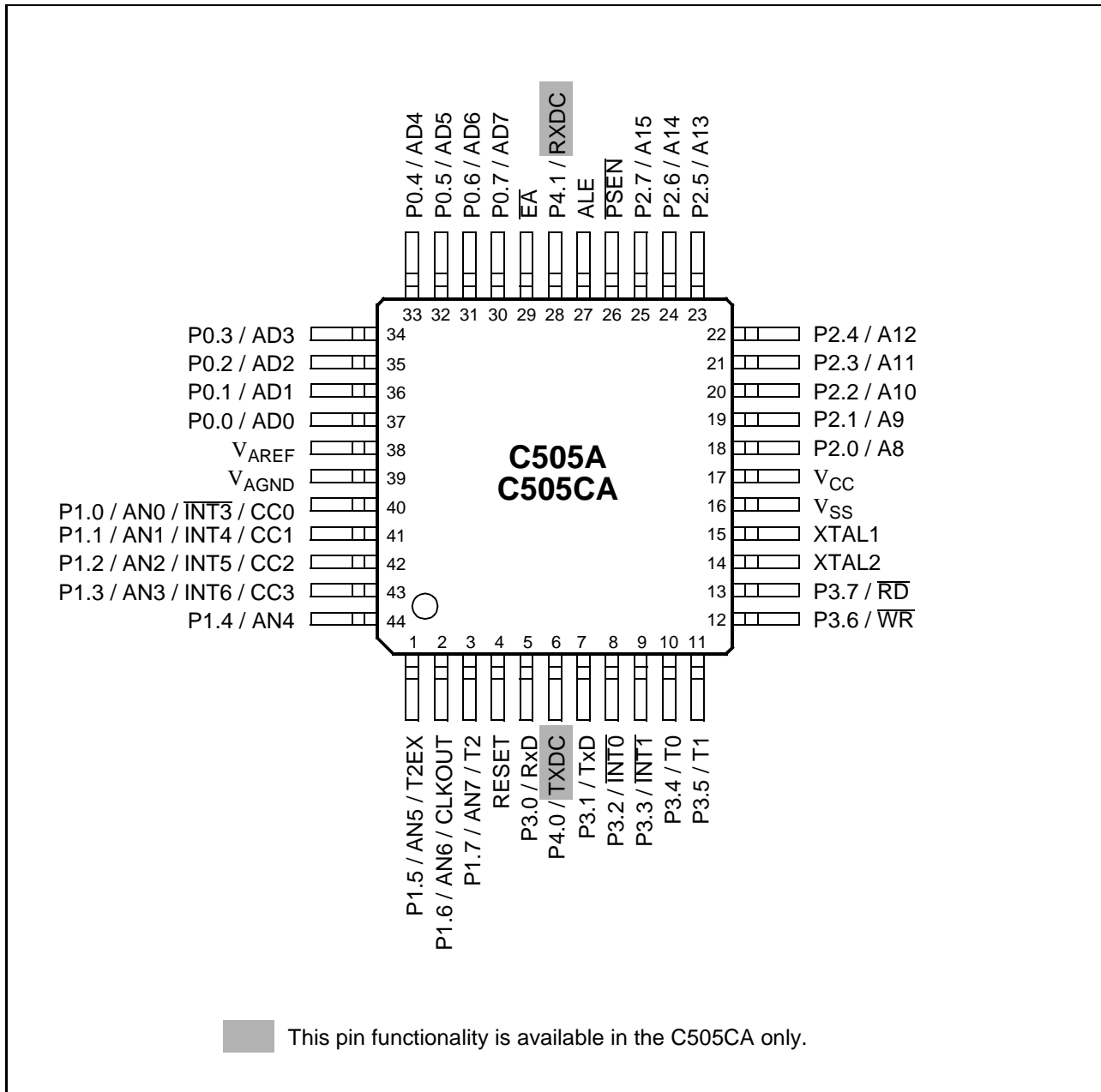

Figure 1-3
Pin Configuration (Top View)

1.2 Pin Definitions and Functions

This section describes all external signals of the C505A with its function.

Table 1-1 :
Pin Definitions and Functions

Symbol	Pin Number	I/O)	Function
P1.0-P1.7	40-44,1-3	I/O	<p>Port 1 is an 8-bit quasi-bidirectional port with internal pull-up arrangement. Port 1 pins can be used for digital input/output or as analog inputs of the A/D converter. Port 1 pins that have 1's written to them are pulled high by internal pull-up transistors and in that state can be used as inputs. As inputs, port 1 pins being externally pulled low will source current (I_{IL}, in the DC characteristics) because of the internal pullup transistors. Port 1 pins are assigned to be used as analog inputs via the register P1ANA. As secondary digital functions, port 1 contains the interrupt, timer, clock, capture and compare pins. The output latch corresponding to a secondary function must be programmed to a one (1) for that function to operate (except for compare functions). The secondary functions are assigned to the pins of port 1 as follows:</p>
	40		P1.0 / AN0 / INT3 / CC0 Analog input channel 0 interrupt 3 input / capture/compare channel 0 I/O
	41		P1.1 / AN1 / INT4 / CC1 Analog input channel 1/ interrupt 4 input / capture/compare channel 1 I/O
	42		P1.2 / AN2 / INT5 / CC2 Analog input channel 2 / interrupt 5 input / capture/compare channel 2 I/O
	43		P1.3 / AN3 / INT6 / CC3 Analog input channel 3 interrupt 6 input / capture/compare channel 4 I/O
	44		P1.4 / AN4 Analog input channel 4
	1		P1.5 / AN5 / T2EX Analog input channel 5 / Timer 2 external reload / trigger input
	2		P1.6 / AN6 / CLKOUT Analog input channel 6 / system clock output
	3		P1.7 / AN7 / T2 Analog input channel 7 / counter 2 input

*) I = Input
O = Output

Table 1-1 :
Pin Definitions and Functions (cont'd)

Symbol	Pin Number	I/O)	Function																								
RESET	4	I	RESET A high level on this pin for two machine cycles while the oscillator is running resets the device. An internal diffused resistor to V_{SS} permits power-on reset using only an external capacitor to V_{CC} .																								
P3.0-P3.7	5, 7-13	I/O	Port 3 is an 8-bit quasi-bidirectional port with internal pull-up arrangement. Port 3 pins that have 1's written to them are pulled high by the internal pull-up transistors and in that state can be used as inputs. As inputs, port 3 pins being externally pulled low will source current (I_{IL} , in the DC characteristics) because of the internal pullup transistors. The output latch corresponding to a secondary function must be programmed to a one (1) for that function to operate (except for TxD and \overline{WR}). The secondary functions are assigned to the pins of port 3 as follows: <table border="0" style="width: 100%; border-collapse: collapse;"> <tr> <td style="width: 10%; text-align: center;">5</td> <td style="width: 20%;">P3.0 / RxD</td> <td style="width: 70%;">Receiver data input (asynch.) or data input/output (synch.) of serial interface</td> </tr> <tr> <td style="text-align: center;">7</td> <td>P3.1 / TxD</td> <td>Transmitter data output (asynch.) or clock output (synch.) of serial interface</td> </tr> <tr> <td style="text-align: center;">8</td> <td>P3.2 / $\overline{INT0}$</td> <td>External interrupt 0 input / timer 0 gate control input</td> </tr> <tr> <td style="text-align: center;">9</td> <td>P3.3 / $\overline{INT1}$</td> <td>External interrupt 1 input / timer 1 gate control input</td> </tr> <tr> <td style="text-align: center;">10</td> <td>P3.4 / T0</td> <td>Timer 0 counter input</td> </tr> <tr> <td style="text-align: center;">11</td> <td>P3.5 / T1</td> <td>Timer 1 counter input</td> </tr> <tr> <td style="text-align: center;">12</td> <td>P3.6 / \overline{WR}</td> <td>\overline{WR} control output; latches the data byte from port 0 into the external data memory</td> </tr> <tr> <td style="text-align: center;">13</td> <td>P3.7 / \overline{RD}</td> <td>\overline{RD} control output; enables the external data memory</td> </tr> </table>	5	P3.0 / RxD	Receiver data input (asynch.) or data input/output (synch.) of serial interface	7	P3.1 / TxD	Transmitter data output (asynch.) or clock output (synch.) of serial interface	8	P3.2 / $\overline{INT0}$	External interrupt 0 input / timer 0 gate control input	9	P3.3 / $\overline{INT1}$	External interrupt 1 input / timer 1 gate control input	10	P3.4 / T0	Timer 0 counter input	11	P3.5 / T1	Timer 1 counter input	12	P3.6 / \overline{WR}	\overline{WR} control output; latches the data byte from port 0 into the external data memory	13	P3.7 / \overline{RD}	\overline{RD} control output; enables the external data memory
5	P3.0 / RxD	Receiver data input (asynch.) or data input/output (synch.) of serial interface																									
7	P3.1 / TxD	Transmitter data output (asynch.) or clock output (synch.) of serial interface																									
8	P3.2 / $\overline{INT0}$	External interrupt 0 input / timer 0 gate control input																									
9	P3.3 / $\overline{INT1}$	External interrupt 1 input / timer 1 gate control input																									
10	P3.4 / T0	Timer 0 counter input																									
11	P3.5 / T1	Timer 1 counter input																									
12	P3.6 / \overline{WR}	\overline{WR} control output; latches the data byte from port 0 into the external data memory																									
13	P3.7 / \overline{RD}	\overline{RD} control output; enables the external data memory																									

*) I = Input
O = Output

Table 1-1 :
Pin Definitions and Functions (cont'd)

Symbol	Pin Number	I/O)	Function
P4.0 P4.1	6 28	I/O I/O	<p>Port 4 is a 2-bit quasi-bidirectional port with internal pull-up arrangement. Port 4 pins that have 1's written to them are pulled high by the internal pull-up transistors and in that state can be used as inputs. As inputs, port 4 pins being externally pulled low will source current (I_{IL}, in the DC characteristics) because of the internal pullup transistors. The output latch corresponding to the secondary function RXDC must be programmed to a one (1) for that function to operate. The secondary functions are assigned to the two pins of port 4 as follows (C505CA only) :</p> <p>P4.0 / TXDC Transmitter output of CAN controller P4.1 / RXDC Receiver input of CAN controller</p>
XTAL2	14	O	<p>XTAL2 Output of the inverting oscillator amplifier.</p>
XTAL1	15	I	<p>XTAL1 Input to the inverting oscillator amplifier and input to the internal clock generator circuits. To drive the device from an external clock source, XTAL1 should be driven, while XTAL2 is left unconnected. To operate above a frequency of 16 MHz, a duty cycle of the external clock signal of 50 % should be maintained. Minimum and maximum high and low times as well as rise/fall times specified in the AC characteristics must be observed.</p>

*) I = Input
O = Output

Table 1-1 :
Pin Definitions and Functions (cont'd)

Symbol	Pin Number	I/O)	Function
P2.0-P2.7	18-25	I/O	Port 2 is a an 8-bit quasi-bidirectional I/O port with internal pullup resistors. Port 2 pins that have 1's written to them are pulled high by the internal pullup resistors, and in that state can be used as inputs. As inputs, port 2 pins being externally pulled low will source current (I_{IL} , in the DC characteristics) because of the internal pullup resistors. Port 2 emits the high-order address byte during fetches from external program memory and during accesses to external data memory that use 16-bit addresses (MOVX @DPTR). In this application it uses strong internal pullup transistors when issuing 1s. During accesses to external data memory that use 8-bit addresses (MOVX @Ri), port 2 issues the contents of the P2 special function register and uses only the internal pullup resistors.
PSEN	26	O	The Program Store Enable output is a control signal that enables the external program memory to the bus during external fetch operations. It is activated every three oscillator periods except during external data memory accesses. Remains high during internal program execution. This pin should not be driven during reset operation.
ALE	27	O	The Address Latch Enable output is used for latching the low-byte of the address into external memory during normal operation. It is activated every three oscillator periods except during an external data memory access. When instructions are executed from internal OTP ($\overline{EA}=1$) the ALE generation can be disabled by bit EALE in SFR SYSCON. ALE should not be driven during reset operation.

*) I = Input
O = Output

Table 1-1 :
Pin Definitions and Functions (cont'd)

Symbol	Pin Number	I/O)	Function
\overline{EA}	29	I	External Access Enable When held at high level, instructions are fetched from the internal OTP memory when the PC is less than 8000H. When held at low level, the C505A/C505CA fetches all instructions from external program memory. \overline{EA} should not be driven during reset operation. For the C505A-L and the C505CA-L this pin must be tied low.
P0.0-P0.7	37-30	I/O	Port 0 is an 8-bit open-drain bidirectional I/O port. Port 0 pins that have 1's written to them float, and in that state can be used as high-impedance inputs. Port 0 is also the multiplexed low-order address and data bus during accesses to external program or data memory. In this application it uses strong internal pullup transistors when issuing 1's.
V_{AREF}	38	–	Reference voltage for the A/D converter.
V_{AGND}	39	–	Reference ground for the A/D converter.
V_{SS}	16	–	Ground (0V)
V_{CC}	17	–	Power Supply (+5V)

*) I = Input
O = Output

2 Memory Organization

The C505A CPU manipulates operands in the following four address spaces:

- up to 64 Kbytes of program memory (32K on-chip OTP memory for C505A-4E)
- up to 64 Kbytes of external data memory
- 256 bytes of internal data memory
- 1 Kbytes of internal XRAM data memory
- 256 bytes CAN controller registers / data memory (C505CA only)
- a 128 byte special function register area

Figure 2-1 illustrates the memory address spaces of the C505A.

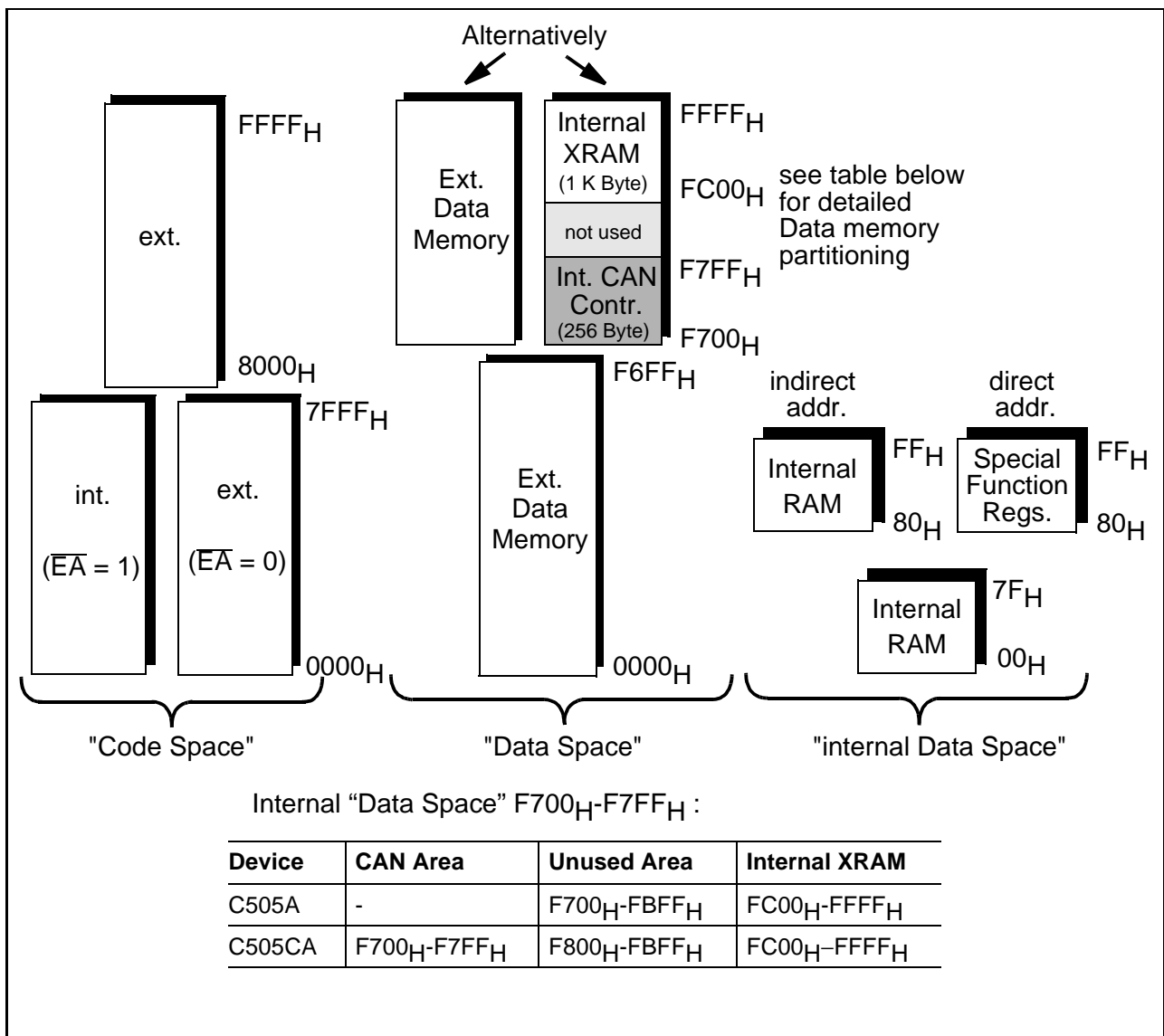

Figure 2-1
C505A Memory Map

2.1 Program Memory, "Code Space"

The C505A-4E has 32 Kbytes of on-chip OTP program memory which can be externally expanded up to 64 Kbytes. If the \overline{EA} pin is held high, the C505A-4E executes program code out of the OTP memory unless the program counter address exceeds $7FFF_H$. Address locations 8000_H through $FFFF_H$ are then fetched from the external program memory. If the \overline{EA} pin is held low, the C505A fetches all instructions from the external program memory.

2.2 Data Memory, "Data Space"

The data memory address space consists of an internal and an external memory space. The internal data memory is divided into three physically separate and distinct blocks : the lower 128 bytes of RAM, the upper 128 bytes of RAM, and the 128 byte special function register (SFR) area. While the upper 128 bytes of data memory and the SFR area share the same address locations, they are accessed through different addressing modes. The lower 128 bytes of data memory can be accessed through direct or register indirect addressing; the upper 128 bytes of RAM can be accessed through register indirect addressing; the special function registers are accessible through direct addressing. Four 8-register banks, each bank consisting of eight 8-bit general-purpose registers, occupy locations 0 through $1F_H$ in the lower RAM area. The next 16 bytes, locations 20_H through $2F_H$, contain 128 directly addressable bit locations. The stack can be located anywhere in the internal RAM area, and the stack depth can be expanded up to 256 bytes.

The external data memory can be expanded up to 64 Kbyte and can be accessed by instructions that use a 16-bit or an 8-bit address. The internal CAN controller (in C505CA only) and the internal 1 Kbyte XRAM are located in the external memory address area at addresses $F700_H$ to $F7FF_H$ and $FC00_H$ to $FFFF_H$ respectively. The CAN controller registers and internal XRAM can therefore be accessed using MOVX instructions with addresses pointing to the respective address areas.

2.3 General Purpose Registers

The lower 32 locations of the internal RAM are assigned to four banks of eight general purpose registers (GPRs) each. Only one of these banks may be enabled at a time. Two bits in the program status word, RS0 (PSW.3) and RS1 (PSW.4), select the active register bank (see description of the PSW in chapter 2). This allows fast context switching, which is useful when entering subroutines or interrupt service routines.

The 8 general purpose registers of the selected register bank may be accessed by register addressing. With register addressing the instruction op code indicates which register is to be used. For indirect addressing R0 and R1 are used as pointer or index register to address internal or external memory (e.g. MOV @R0).

Reset initializes the stack pointer to location 07_H and increments it once to start from location 08_H which is also the first register (R0) of register bank 1. Thus, if one is going to use more than one register bank, the SP should be initialized to a different location of the RAM which is not used for data storage.

2.4 Special Function Registers

The registers, except the program counter and the four general purpose register banks, reside in the special function register area. The special function register area consists of two portions : the standard special function register area and the mapped special function register area. One special function register of the C505A (PCON1) is located in the mapped special function register area. For accessing the mapped special function register area, bit RMAP in special function register SYSCON must be set. All other special function registers are located in the standard special function register area which is accessed when RMAP is cleared (“0”).

In the C505CA, the registers and data locations of the CAN controller (CAN-SFRs) are located in the external data memory area at addresses F700_H to F7FF_H. This is compatible to the C505C and details about the access of these registers is described in the C505C User’s Manual.

Special Function Register SYSCON (Address B1_H) **Reset Value : XX100X01_B**
(C505CA only) Reset Value : XX100001_B

Bit No.	MSB							LSB	SYSCON
	7	6	5	4	3	2	1	0	
B1 _H	-	-	EALE	RMAP	CMOD	CSWO 1)	XMAP1	XMAP0	

The functions of the shaded bits are not described here.

1) This bit is available in the C505CA only.

Bit	Function
CSWO	CAN Controller switch-off bit CPWD = 0 : CAN Controller is enabled (default after reset). CPWD = 1 : CAN Controller is switched off. This function is an enhancement over the C505C-2R.
-	Reserved bits for future use. Read by CPU returns undefined values.

As long as bit RMAP is set, mapped special function register area can be accessed. This bit is not cleared by hardware automatically. Thus, when non-mapped/mapped registers are to be accessed, the bit RMAP must be cleared/set respectively by software.

All SFRs with addresses where address bits 0-2 are 0 (e.g. 80_H, 88_H, 90_H, 98_H, ..., F8_H, FF_H) are bitaddressable.

The 52 special function registers (SFRs) in the standard and mapped SFR area include pointers and registers that provide an interface between the CPU and the other on-chip peripherals. The SFRs of the C505A are listed in **table 2-1** and **table 2-2**. In **table 2-1** they are organized in groups which refer to the functional blocks of the C505A. The CAN-SFRs (applicable to the C505CA only) are also included in **table 2-1**. **Table 2-2** illustrates the contents of the SFRs in numeric order of their addresses. **Table 2-3** list the CAN-SFRs in numeric order of their addresses.

Table 2-1
Special Function Registers - Functional Blocks

Block	Symbol	Name	Address	Contents after Reset
CPU	ACC	Accumulator	E0H ¹⁾	00H
	B	B-Register	F0H ¹⁾	00H
	DPH	Data Pointer, High Byte	83H	00H
	DPL	Data Pointer, Low Byte	82H	00H
	DPSEL	Data Pointer Select Register	92H	XXXXX000B ³⁾
	PSW	Program Status Word Register	D0H ¹⁾	00H
	SP	Stack Pointer	81H	07H
	SYSCON ²⁾	System Control Register	B1H	XX100X01B ^{3) 6)} XX100101B ^{3) 7)}
	VR0 ⁴⁾	Version Register 0	FC _H	C5 _H
	VR1 ⁴⁾	Version Register 1	FD _H	05 _H
VR2 ⁴⁾	Version Register 2	FE _H	⁵⁾	
A/D- Converter	ADCON0 ²⁾	A/D Converter Control Register 0	D8H ¹⁾	00X00000B ³⁾
	ADCON1	A/D Converter Control Register 1	DC _H	01XXX000B ³⁾
	ADDATH	A/D Converter High Byte Data Register	D9 _H	00H
	ADDATL	A/D Converter Low Byte Data Register	DA _H	00XXXXXXB ³⁾
	P1ANA ^{2) 4)}	Port 1 Analog Input Selection Register	90 _H	FF _H
Interrupt System	IEN0 ²⁾	Interrupt Enable Register 0	A8H ¹⁾	00H
	IEN1 ²⁾	Interrupt Enable Register 1	B8H ¹⁾	00H
	IP0 ²⁾	Interrupt Priority Register 0	A9 _H	00H
	IP1	Interrupt Priority Register 1	B9 _H	XX000000B ³⁾
	TCON ²⁾	Timer Control Register	88H ¹⁾	00H
	T2CON ²⁾	Timer 2 Control Register	C8H ¹⁾	00X00000B
	SCON ²⁾	Serial Channel Control Register	98H ¹⁾	00H
	IRCON	Interrupt Request Control Register	C0H ¹⁾	00H
XRAM	XPAGE	Page Address Register for Extended on-chip XRAM and CAN Controller	91 _H	00H
	SYSCON ²⁾	System Control Register	B1 _H	XX100X01B ^{3) 6)} XX100101B ^{3) 7)}
Ports	P0	Port 0	80H ¹⁾	FF _H
	P1	Port 1	90H ¹⁾	FF _H
	P1ANA ^{2) 4)}	Port 1 Analog Input Selection Register	90H ¹⁾	FF _H
	P2	Port 2	A0H ¹⁾	FF _H
	P3	Port 3	B0H ¹⁾	FF _H
	P4	Port 4	E8H ¹⁾	XXXXXX11B

1) Bit-addressable special function registers

2) This special function register is listed repeatedly since some bits of it also belong to other functional blocks.

3) "X" means that the value is undefined and the location is reserved

4) This SFR is a mapped SFR. For accessing this SFR, bit RMAP in SFR SYSCON must be set.

5) The content of this SFR varies with the actual step of the C505A (eg. 11_H for the first step)

6) C505A only

7) C505CA only

Table 2-1
Special Function Registers - Functional Blocks (cont'd)

Block	Symbol	Name	Address	Contents after Reset
Serial Channel	ADCON0 ²⁾	A/D Converter Control Register 0	D8H ¹⁾	00X00000B ³⁾
	PCON ²⁾	Power Control Register	87H	00H
	SBUF	Serial Channel Buffer Register	99H	XXH ³⁾
	SCON	Serial Channel Control Register	98H ¹⁾	00H
	SRELL	Serial Channel Reload Register, low byte	AAH	D9H
	SRELH	Serial Channel Reload Register, high byte	BAH	XXXXXX11B ³⁾
Timer 0/ Timer 1	TCON	Timer 0/1 Control Register	88H ¹⁾	00H
	TH0	Timer 0, High Byte	8CH	00H
	TH1	Timer 1, High Byte	8DH	00H
	TL0	Timer 0, Low Byte	8AH	00H
	TL1	Timer 1, Low Byte	8BH	00H
	TMOD	Timer Mode Register	89H	00H
Compare/ Capture Unit / Timer 2	CCEN	Comp./Capture Enable Reg.	C1H	00H ³⁾
	CCH1	Comp./Capture Reg. 1, High Byte	C3H	00H
	CCH2	Comp./Capture Reg. 2, High Byte	C5H	00H
	CCH3	Comp./Capture Reg. 3, High Byte	C7H	00H
	CCL1	Comp./Capture Reg. 1, Low Byte	C2H	00H
	CCL2	Comp./Capture Reg. 2, Low Byte	C4H	00H
	CCL3	Comp./Capture Reg. 3, Low Byte	C6H	00H
	CRCH	Reload Register High Byte	CBH	00H
	CRCL	Reload Register Low Byte	CAH	00H
	TH2	Timer 2, High Byte	CDH	00H
	TL2	Timer 2, Low Byte	CCH	00H
	T2CON	Timer 2 Control Register	C8H ¹⁾	00X00000B ³⁾
	IEN0 ²⁾	Interrupt Enable Register 0	A8H ¹⁾	00H
	IEN1 ²⁾	Interrupt Enable Register 1	B8H ¹⁾	00H
Watchdog	WDTREL	Watchdog Timer Reload Register	86H	00H
	IEN0 ²⁾	Interrupt Enable Register 0	A8H ¹⁾	00H
	IEN1 ²⁾	Interrupt Enable Register 1	B8H ¹⁾	00H
	IPO ²⁾	Interrupt Priority Register 0	A9H	00H
Power Save Modes	PCON ²⁾	Power Control Register	87H	00H
	PCON1 ⁴⁾	Power Control Register 1	88H ¹⁾	0XX0XXXXB ³⁾

1) Bit-addressable special function registers

2) This special function register is listed repeatedly since some bits of it also belong to other functional blocks.

3) "X" means that the value is undefined and the location is reserved

4) SFR is located in the mapped SFR area. For accessing this SFR, bit RMAP in SFR SYSCON must be set.

**Table 2-1
Special Function Registers - Functional Blocks (cont'd)**

Block	Symbol	Name	Address	Contents after Reset	
CAN Controller	CR	Control Register	F700 _H	01 _H	
	SR	Status Register	F701 _H	XX _H ³⁾	
	IR	Interrupt Register	F702 _H	XX _H ³⁾	
(C505CA only)	BTR0	Bit Timing Register Low	F704 _H	UU _H ³⁾	
	BTR1	Bit Timing Register High	F705 _H	0UUUUUU _B ³⁾	
	GMS0	Global Mask Short Register Low	F706 _H	UU _H ³⁾	
	GMS1	Global Mask Short Register High	F707 _H	UUU11111 _B ³⁾	
	UGML0	Upper Global Mask Long Register Low	F708 _H	UU _H ³⁾	
	UGML1	Upper Global Mask Long Register High	F709 _H	UU _H ³⁾	
	LGML0	Lower Global Mask Long Register Low	F70A _H	UU _H ³⁾	
	LGML1	Lower Global Mask Long Register High	F70B _H	UUUUU000 _B ³⁾	
	UMLM0	Upper Mask of Last Message Register Low	F70C _H	UU _H ³⁾	
	UMLM1	Upper Mask of Last Message Register High	F70D _H	UU _H ³⁾	
	LMLM0	Lower Mask of Last Message Register Low	F70E _H	UU _H ³⁾	
	LMLM1	Lower Mask of Last Message Register High	F70F _H	UUUUU000 _B ³⁾	
	Message Object Registers :				
		MCR0	Message Control Register Low	F7n0 _H ⁵⁾	UU _H ³⁾
		MCR1	Message Control Register High	F7n1 _H ⁵⁾	UU _H ³⁾
		UAR0	Upper Arbitration Register Low	F7n2 _H ⁵⁾	UU _H ³⁾
		UAR1	Upper Arbitration Register High	F7n3 _H ⁵⁾	UU _H ³⁾
		LAR0	Lower Arbitration Register Low	F7n4 _H ⁵⁾	UU _H ³⁾
		LAR1	Lower Arbitration Register High	F7n5 _H ⁵⁾	UUUUU000 _B ³⁾
		MCFG	Message Configuration Register	F7n6 _H ⁵⁾	UUUUUU00 _B ³⁾
		DB0	Message Data Byte 0	F7n7 _H ⁵⁾	XX _H ³⁾
		DB1	Message Data Byte 1	F7n8 _H ⁵⁾	XX _H ³⁾
		DB2	Message Data Byte 2	F7n9 _H ⁵⁾	XX _H ³⁾
		DB3	Message Data Byte 3	F7nA _H ⁵⁾	XX _H ³⁾
		DB4	Message Data Byte 4	F7nB _H ⁵⁾	XX _H ³⁾
		DB5	Message Data Byte 5	F7nC _H ⁵⁾	XX _H ³⁾
		DB6	Message Data Byte 6	F7nD _H ⁵⁾	XX _H ³⁾
	DB7	Message Data Byte 7	F7nE _H ⁵⁾	XX _H ³⁾	

- 1) Bit-addressable special function registers
- 2) This special function register is listed repeatedly since some bits of it also belong to other functional blocks.
- 3) "X" means that the value is undefined and the location is reserved. "U" means that the value is unchanged by a reset operation. "U" values are undefined (as "X") after a power-on reset operation
- 4) SFR is located in the mapped SFR area. For accessing this SFR, bit RMAP in SFR SYSCON must be set.
- 5) The notation "n" (n= 1 to F) in the message object address definition defines the number of the related message object.

Table 2-2
Contents of the SFRs, SFRs in numeric order of their addresses

Addr	Register	Content after Reset ¹⁾	Bit 7	Bit 6	Bit 5	Bit 4	Bit 3	Bit 2	Bit 1	Bit 0
80 _H ²⁾	P0	FF _H	.7	.6	.5	.4	.3	.2	.1	.0
81 _H	SP	07 _H	.7	.6	.5	.4	.3	.2	.1	.0
82 _H	DPL	00 _H	.7	.6	.5	.4	.3	.2	.1	.0
83 _H	DPH	00 _H	.7	.6	.5	.4	.3	.2	.1	.0
86 _H	WDTREL	00 _H	WDT PSEL	.6	.5	.4	.3	.2	.1	.0
87 _H	PCON	00 _H	SMOD	PDS	IDLS	SD	GF1	GF0	PDE	IDLE
88 _H ²⁾	TCON	00 _H	TF1	TR1	TF0	TR0	IE1	IT1	IE0	IT0
88 _H ³⁾	PCON1	0XX0- XXXX _B	EWPD	–	–	WS	–	–	–	–
89 _H	TMOD	00 _H	GATE	C/T	M1	M0	GATE	C/T	M1	M0
8A _H	TL0	00 _H	.7	.6	.5	.4	.3	.2	.1	.0
8B _H	TL1	00 _H	.7	.6	.5	.4	.3	.2	.1	.0
8C _H	TH0	00 _H	.7	.6	.5	.4	.3	.2	.1	.0
8D _H	TH1	00 _H	.7	.6	.5	.4	.3	.2	.1	.0
90 _H ²⁾	P1	FF _H	T2	CLK- OUT	T2EX	.4	.3	INT5	INT4	.0
90 _H ³⁾	P1ANA	FF _H	EAN7	EAN6	EAN5	EAN4	EAN3	EAN2	EAN1	EAN0
91 _H	XPAGE	00 _H	.7	.6	.5	.4	.3	.2	.1	.0
92 _H	DPSEL	XXXX- X000 _B	–	–	–	–	–	.2	.1	.0
98 _H ²⁾	SCON	00 _H	SM0	SM1	SM2	REN	TB8	RB8	TI	RI
99 _H	SBUF	XX _H	.7	.6	.5	.4	.3	.2	.1	.0
A0 _H ²⁾	P2	FF _H	.7	.6	.5	.4	.3	.2	.1	.0
A8 _H ²⁾	IEN0	00 _H	EA	WDT	ET2	ES	ET1	EX1	ET0	EX0
A9 _H	IP0	00 _H	OWDS	WDTS	.5	.4	.3	.2	.1	.0
AA _H	SRELL	D9 _H	.7	.6	.5	.4	.3	.2	.1	.0

1) X means that the value is undefined and the location is reserved

2) Bit-addressable special function registers

3) SFR is located in the mapped SFR area. For accessing this SFR, bit RMAP in SFR SYSCON must be set.

Table 2-2
Contents of the SFRs, SFRs in numeric order of their addresses (cont'd)

Addr	Register	Content after Reset ¹⁾	Bit 7	Bit 6	Bit 5	Bit 4	Bit 3	Bit 2	Bit 1	Bit 0
B0 _H ²⁾	P3	FF _H	RD	WR	T1	T0	INT1	INT0	TxD	RxD
B1 _H	SYSCON ³⁾	XX10-0X01 _B	–	–	EALE	RMAP	CMOD	–	XMAP1	XMAP0
B1 _H	SYSCON ⁴⁾	XX10-0001 _B	–	–	EALE	RMAP	CMOD	CSWO	XMAP1	XMAP0
B8 _H ²⁾	IEN1 ³⁾	0000-00X0 _B	EXEN2	SWDT	EX6	EX5	EX4	EX3	–	EADC
B8 _H ²⁾	IEN1 ⁴⁾	00 _H	EXEN2	SWDT	EX6	EX5	EX4	EX3	ECAN	EADC
B9 _H	IP1	XX00-0000 _B	–	–	.5	.4	.3	.2	.1	.0
BA _H	SRELH	XXXX-XX11 _B	–	–	–	–	–	–	.1	.0
C0 _H ²⁾	IRCON	00 _H	EXF2	TF2	IEX6	IEX5	IEX4	IEX3	SWI	IADC
C1 _H	CCEN	00 _H	COCA H3	COCA L3	COCA H2	COCA L2	COCA H1	COCA L1	COCA H0	COCA L0
C2 _H	CCL1	00 _H	.7	.6	.5	.4	.3	.2	.1	.0
C3 _H	CCH1	00 _H	.7	.6	.5	.4	.3	.2	.1	.0
C4 _H	CCL2	00 _H	.7	.6	.5	.4	.3	.2	.1	.0
C5 _H	CCH2	00 _H	.7	.6	.5	.4	.3	.2	.1	.0
C6 _H	CCL3	00 _H	.7	.6	.5	.4	.3	.2	.1	.0
C7 _H	CCH3	00 _H	.7	.6	.5	.4	.3	.2	.1	.0
C8 _H ²⁾	T2CON	00X0-0000 _B	T2PS	I3FR	–	T2R1	T2R0	T2CM	T2I1	T2I0
CA _H	CRCL	00 _H	.7	.6	.5	.4	.3	.2	.1	.0
CB _H	CRCH	00 _H	.7	.6	.5	.4	.3	.2	.1	.0
CC _H	TL2	00 _H	.7	.6	.5	.4	.3	.2	.1	.0
CD _H	TH2	00 _H	.7	.6	.5	.4	.3	.2	.1	.0
D0 _H ²⁾	PSW	00 _H	CY	AC	F0	RS1	RS0	OV	F1	P

1) X means that the value is undefined and the location is reserved

2) Bit-addressable special function registers

3) C505A only

4) C505CA only

Table 2-2
Contents of the SFRs, SFRs in numeric order of their addresses (cont'd)

Addr	Register	Content after Reset ¹⁾	Bit 7	Bit 6	Bit 5	Bit 4	Bit 3	Bit 2	Bit 1	Bit 0
D8 _H ²⁾	ADCON0	00X0-0000 _B	BD	CLK	–	BSY	ADM	MX2	MX1	MX0
D9 _H	ADDATH	00 _H	.9	.8	.7	.6	.5	.4	.3	.2
DA _H	ADDATL	00XX-XXXX _B	.1	.0	–	–	–	–	–	–
DC _H	ADCON1	01XX-X000 _B	ADCL1	ADCL0	–	–	–	MX2	MX1	MX0
E0 _H ²⁾	ACC	00 _H	.7	.6	.5	.4	.3	.2	.1	.0
E8 _H ²⁾	P4 ³⁾	XXXX-XX11 _B	–	–	–	–	–	–	–	–
E8 _H ²⁾	P4 ⁴⁾	XXXX-XX11 _B	–	–	–	–	–	–	RXDC	TXDC
F0 _H ²⁾	B	00 _H	.7	.6	.5	.4	.3	.2	.1	.0
FC _H ^{5) 6)}	VR0	C5 _H	.7	.6	.5	.4	.3	.2	.1	.0
FD _H ^{5) 6)}	VR1	05 _H	.7	.6	.5	.4	.3	.2	.1	.0
FE _H ^{5) 6)}	VR2	7)	.7	.6	.5	.4	.3	.2	.1	.0

1) X means that the value is undefined and the location is reserved

2) Bit-addressable special function registers

3) C505A only

4) C505CA only

5) SFR is located in the mapped SFR area. For accessing this SFR, bit RMAP in SFR SYSCON must be set.

6) These are read-only registers

7) The content of this SFR varies with the actual of the step C505A (eg. 11_H for the first step)

Table 2-3

Contents of the CAN Registers in numeric order of their addresses (C505CA only)

Addr. n=1-F _H 1)	Register	Content after Reset 2)	Bit 7	Bit 6	Bit 5	Bit 4	Bit 3	Bit 2	Bit 1	Bit 0
F700 _H	CR	01 _H	TEST	CCE	0	0	EIE	SIE	IE	INIT
F701 _H	SR	XX _H	BOFF	EWRN	–	RXOK	TXOK	LEC2	LEC1	LEC0
F702 _H	IR	XX _H	INTID							
F704 _H	BTR0	UU _H	SJW			BRP				
F705 _H	BTR1	0UUU. UUUU _B	0	TSEG2			TSEG1			
F706 _H	GMS0	UU _H	ID28-21							
F707 _H	GMS1	UUU1. 1111 _B	ID20-18			1	1	1	1	1
F708 _H	UGML0	UU _H	ID28-21							
F709 _H	UGML1	UU _H	ID20-13							
F70A _H	LGML0	UU _H	ID12-5							
F70B _H	LGML1	UUUU. U000 _B	ID4-0				0	0	0	
F70C _H	UMLM0	UU _H	ID28-21							
F70D _H	UMLM1	UU _H	ID20-18			ID17-13				
F70E _H	LMLM0	UU _H	ID12-5							
F70F _H	LMLM1	UUUU. U000 _B	ID4-0				0	0	0	
F7n0 _H	MCR0	UU _H	MSGVAL		TXIE		RXIE		INTPND	
F7n1 _H	MCR1	UU _H	RMT PND		TXRQ		MSGLST CPUUPD		NEWDAT	
F7n2 _H	UAR0	UU _H	ID28-21							
F7n3 _H	UAR1	UU _H	ID20-18			ID17-13				
F7n4 _H	LAR0	UU _H	ID12-5							
F7n5 _H	LAR1	UUUU. U000 _B	ID4-0				0	0	0	
F7n6 _H	MCFG	UUUU. UU00 _B	DLC			DIR	XTD	0	0	

1) The notation “n” (n= 1 to F) in the address definition defines the number of the related message object.

2) “X” means that the value is undefined and the location is reserved. “U” means that the value is unchanged by a reset operation. “U” values are undefined (as “X”) after a power-on reset operation

Table 2-3

Contents of the CAN Registers in numeric order of their addresses (cont'd) (C505CA only)

Addr. n=1-F _H 1)	Register	Content after Reset 2)	Bit 7	Bit 6	Bit 5	Bit 4	Bit 3	Bit 2	Bit 1	Bit 0
F7n7 _H	DB0	XX _H	.7	.6	.5	.4	.3	.2	.1	.0
F7n8 _H	DB1	XX _H	.7	.6	.5	.4	.3	.2	.1	.0
F7n9 _H	DB2	XX _H	.7	.6	.5	.4	.3	.2	.1	.0
F7nA _H	DB3	XX _H	.7	.6	.5	.4	.3	.2	.1	.0
F7nB _H	DB4	XX _H	.7	.6	.5	.4	.3	.2	.1	.0
F7nC _H	DB5	XX _H	.7	.6	.5	.4	.3	.2	.1	.0
F7nD _H	DB6	XX _H	.7	.6	.5	.4	.3	.2	.1	.0
F7nE _H	DB7	XX _H	.7	.6	.5	.4	.3	.2	.1	.0

1) The notation "n" (n= 1 to F) in the address definition defines the number of the related message object.

2) "X" means that the value is undefined and the location is reserved. "U" means that the value is unchanged by a reset operation. "U" values are undefined (as "X") after a power-on reset operation

3 A/D Converter

The C505A includes a high performance / high speed 10-bit A/D-Converter (ADC) with 8 analog input channels. It operates with a successive approximation technique and uses self calibration mechanisms for reduction and compensation of offset and linearity errors. The A/D converter provides the following features:

- 8 multiplexed input channels (port 1), which can also be used as digital inputs/outputs
- 10-bit resolution
- Single or continuous conversion mode
- Internal start-of-conversion trigger capability
- Interrupt request generation after each conversion
- Using successive approximation conversion technique via a capacitor array
- Built-in hidden calibration of offset and linearity errors

The externally applied reference voltage range has to be held on a fixed value within the specifications. The main functional blocks of the A/D converter are shown in **figure 3-1**.

3.1 A/D Converter Operation

An internal start of a single A/D conversion is triggered by a write-to-ADDATL instruction. The start procedure itself is independent of the value which is written to ADDATL. When single conversion mode is selected (bit ADM=0) only one A/D conversion is performed. In continuous mode (bit ADM=1), after completion of an A/D conversion a new A/D conversion is triggered automatically until bit ADM is reset.

The busy flag BSY (ADCON0.4) is automatically set when an A/D conversion is in progress. After completion of the conversion it is reset by hardware. This flag can be read only, a write has no effect. The interrupt request flag IADC (IRCON.0) is set when an A/D conversion is completed.

The bits MX0 to MX2 in special function register ADCON0 and ADCON1 are used for selection of the analog input channel. The bits MX0 to MX2 are represented in both registers ADCON0 and ADCON1; however, these bits are present only once. Therefore, there are two methods of selecting an analog input channel : If a new channel is selected in ADCON1 the change is automatically done in the corresponding bits MX0 to MX2 in ADCON0 and vice versa.

Port 1 is a dual purpose input/output port. These pins can be used either for digital I/O functions or as the analog inputs. If less than 8 analog inputs are required, the unused analog inputs at port 1 are free for digital I/O functions.

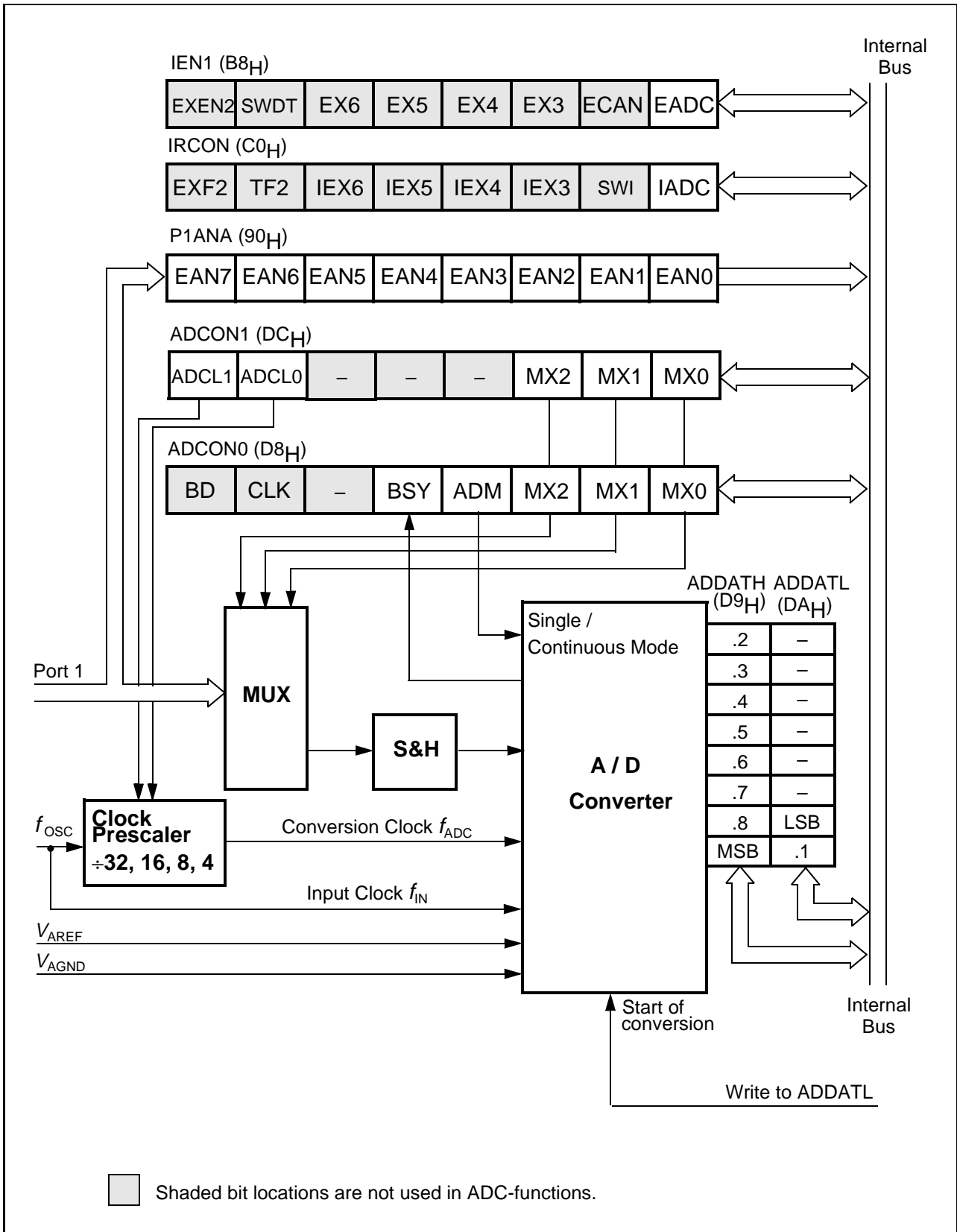

Figure 3-1
Block Diagram of the A/D Converter

3.2 A/D Converter Registers

This section describes the bits/functions of all registers which are used by the A/D converter.

Special Function Register ADDATH (Address D9_H)
Special Function Register ADDATL (Address DA_H)

Reset Value : 00_H
Reset Value : 00XXXXXX_B

Bit No.	MSB							LSB	
	7	6	5	4	3	2	1	0	
D9 _H	MSB .9	.8	.7	.6	.5	.4	.3	.2	ADDATH
DA _H	.1	LSB .0	–	–	–	–	–	–	ADDATL

The registers ADDATH and ADDATL hold the 10-bit conversion result in left justified data format. The most significant bit of the 10-bit conversion result is bit 7 of ADDATH. The least significant bit of the 10-bit conversion result is bit 6 of ADDATL. To get a 10-bit conversion result, both ADDAT registers must be read. If an 8-bit conversion result is required, only the reading of ADDATH is necessary. The data remains in ADDAT until it is overwritten by the next converted data. ADDAT can be read or written under software control. If the A/D converter of the C505A is not used, register ADDATH can be used as an additional general purpose register.

Special Function Register ADCON0 (Address D8_H)
Special Function Register ADCON1 (Address DC_H)

Reset Value : 00_H
Reset Value : 01_HXX000_B

Bit No.	MSB							LSB	
	7	6	5	4	3	2	1		
D8 _H	BD	CLK	–	BSY	ADM	MX2	MX1	MX0	ADCON0
DC _H	ADCL1	ADCL0	–	–	–	MX2	MX1	MX0	ADCON1

The shaded bits are not used for A/D converter control.

Bit	Function																																				
–	Reserved bits for future use																																				
BSY	<p>Busy flag</p> <p>This flag indicates whether a conversion is in progress (BSY = 1). The flag is cleared by hardware when the conversion is finished.</p>																																				
ADM	<p>A/D conversion mode</p> <p>When set, a continuous A/D conversion is selected. If cleared during a running A/D conversion, the conversion is stopped at its end.</p>																																				
MX2 - MX0	<p>A/D converter input channel select bits</p> <p>Bits MX2-0 can be written or read either in ADCON0 or ADCON1. The channel selection done by writing to ADCON 1(0) overwrites the selection in ADCON 0(1) when ADCON 1(0) is written after ADCON 0(1).</p> <p>The analog inputs are selected according the following table :</p> <table border="1" style="width: 100%; border-collapse: collapse;"> <thead> <tr> <th>MX2</th> <th>MX1</th> <th>MX0</th> <th>Selected Analog Input</th> </tr> </thead> <tbody> <tr> <td>0</td> <td>0</td> <td>0</td> <td>P1.0 / AN0 / INT3 / CC0</td> </tr> <tr> <td>0</td> <td>0</td> <td>1</td> <td>P1.1 / AN1 / INT4 / CC1</td> </tr> <tr> <td>0</td> <td>1</td> <td>0</td> <td>P1.2 / AN2 / INT5 / CC2</td> </tr> <tr> <td>0</td> <td>1</td> <td>1</td> <td>P1.3 / AN3 / INT6 / CC3</td> </tr> <tr> <td>1</td> <td>0</td> <td>0</td> <td>P1.4 / AN4</td> </tr> <tr> <td>1</td> <td>0</td> <td>1</td> <td>P1.5 / AN5 / T2EX</td> </tr> <tr> <td>1</td> <td>1</td> <td>0</td> <td>P1.6 / AN6 / CLKOUT</td> </tr> <tr> <td>1</td> <td>1</td> <td>1</td> <td>P1.7 / AN7 / T2</td> </tr> </tbody> </table>	MX2	MX1	MX0	Selected Analog Input	0	0	0	P1.0 / AN0 / INT3 / CC0	0	0	1	P1.1 / AN1 / INT4 / CC1	0	1	0	P1.2 / AN2 / INT5 / CC2	0	1	1	P1.3 / AN3 / INT6 / CC3	1	0	0	P1.4 / AN4	1	0	1	P1.5 / AN5 / T2EX	1	1	0	P1.6 / AN6 / CLKOUT	1	1	1	P1.7 / AN7 / T2
MX2	MX1	MX0	Selected Analog Input																																		
0	0	0	P1.0 / AN0 / INT3 / CC0																																		
0	0	1	P1.1 / AN1 / INT4 / CC1																																		
0	1	0	P1.2 / AN2 / INT5 / CC2																																		
0	1	1	P1.3 / AN3 / INT6 / CC3																																		
1	0	0	P1.4 / AN4																																		
1	0	1	P1.5 / AN5 / T2EX																																		
1	1	0	P1.6 / AN6 / CLKOUT																																		
1	1	1	P1.7 / AN7 / T2																																		

Bit	Function															
ADCL1 ADCL0	<p>A/D converter clock prescaler selection</p> <p>ADCL1 and ADCL0 select the prescaler ratio for the A/D conversion clock f_{ADC}. Depending on the clock rate f_{OSC} of the C505A, f_{ADC} must be adjusted in a way that the resulting conversion clock f_{ADC} is less than or equal to 2 MHz (see section 3.3).</p> <p>The prescaler ratio is selected according to the following table :</p> <table border="1"> <thead> <tr> <th>ADCL1</th> <th>ADCL0</th> <th>Prescaler Ratio</th> </tr> </thead> <tbody> <tr> <td>0</td> <td>0</td> <td>divide by 4</td> </tr> <tr> <td>0</td> <td>1</td> <td>divide by 8 (default after reset)</td> </tr> <tr> <td>1</td> <td>0</td> <td>divide by 16</td> </tr> <tr> <td>1</td> <td>1</td> <td>divide by 32</td> </tr> </tbody> </table>	ADCL1	ADCL0	Prescaler Ratio	0	0	divide by 4	0	1	divide by 8 (default after reset)	1	0	divide by 16	1	1	divide by 32
ADCL1	ADCL0	Prescaler Ratio														
0	0	divide by 4														
0	1	divide by 8 (default after reset)														
1	0	divide by 16														
1	1	divide by 32														

Note : Generally, before entering the power-down mode, an A/D conversion in progress must be stopped. If a single A/D conversion is running, it must be terminated by polling the BSY bit or waiting for the A/D conversion interrupt. In continuous conversion mode, bit ADM must be cleared and the last A/D conversion must be terminated before entering the power-down mode.

A single A/D conversion is started by writing to SFR ADDATL with dummy data. A continuous conversion is started under the following conditions :

- By setting bit ADM during a running single A/D conversion
- By setting bit ADM when at least one A/D conversion has occurred after the last reset operation.
- By writing ADDATL with dummy data after bit ADM has been set before (if no A/D conversion has occurred after the last reset operation).

When bit ADM is reset by software in continuous conversion mode, the just running A/D conversion is stopped after its end.

The A/D converter interrupt is controlled by bits which are located in the SFRs IEN1 and IRCON.

Special Function Register IEN1 (Address B8_H)

Reset Value : 00_H

Special Function Register IRCON (Address C0_H)

Reset Value : 00_H

Bit No.	MSB							LSB	
	BF _H	BE _H	BD _H	BC _H	BB _H	BA _H	B9 _H	B8 _H	
B8 _H	EXEN2	SWDT	EX6	EX5	EX4	EX3	ECAN	EADC	IEN1
	C7 _H	C6 _H	C5 _H	C4 _H	C3 _H	C2 _H	C1 _H	C0 _H	
C0 _H	EXF2	TF2	IEX6	IEX5	IEX4	IEX3	SWI	IADC	IRCON

The shaded bits are not used for A/D converter control.

Bit	Function
EADC	Enable A/D converter interrupt If EADC = 0, the A/D converter interrupt is disabled.
SWI	This bit can be set by software to generate an interrupt. The interrupt service routine is at 004B _H . This bit is cleared when the interrupt is processed. This interrupt is enabled by setting bit IEN1.1(ECAN).

3.3 A/D Converter Clock Selection

The ADC uses two clock signals for operation : the conversion clock f_{ADC} ($=1/t_{ADC}$) and the input clock f_{IN} ($=1/t_{IN}$). f_{ADC} is derived from the C505A system clock f_{OSC} which is applied at the XTAL pins via the ADC clock prescaler as shown in **figure 3-2**. The input clock f_{IN} is equal to f_{OSC} . The conversion f_{ADC} clock is limited to a maximum frequency of 2 MHz. Therefore, the ADC clock prescaler must be programmed to a value which assures that the conversion clock does not exceed 2 MHz. The prescaler ratio is selected by the bits ADCL1 and ADCL0 of SFR ADCON1.

The table in **figure 3-2** shows the prescaler ratio which must be selected by ADCL1 and ADCL0 for typical system clock rates. Up to 8 MHz system clock the prescaler ratio 4 is selected. Using a system clock greater than 8 MHz and less than 16 MHz, the prescaler ratio of at least 8 must be selected. A prescaler ratio of at least 16 must be selected when using a system clock greater than 16 MHz. A prescaler ratio of 32 can be used for any of the above frequency ranges.

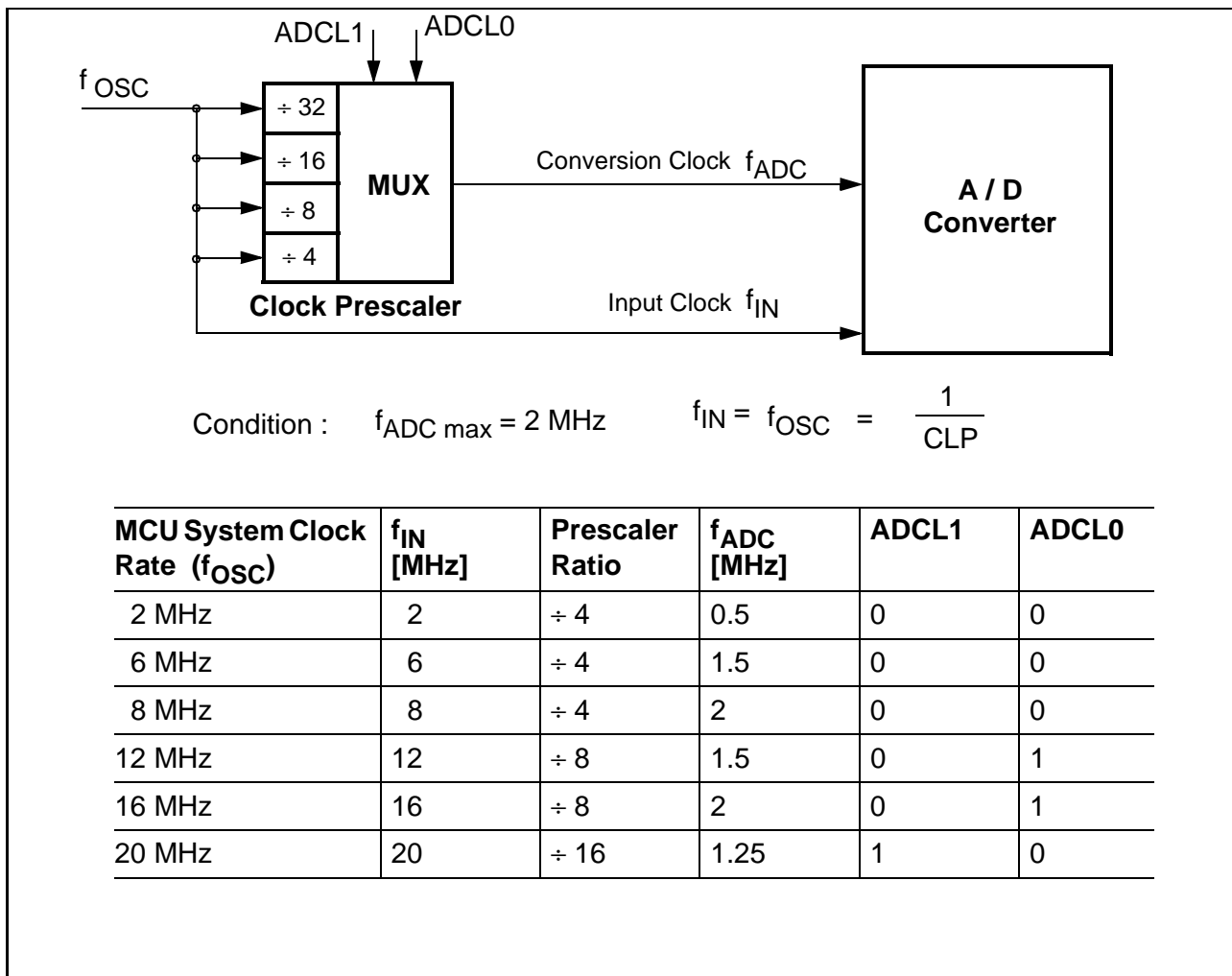

Figure 3-2
A/D Converter Clock Selection

The duration of an A/D conversion is a multiple of the period of the f_{IN} clock signal. The calculation of the A/D conversion time is shown in the next section.

3.4 A/D Conversion Timing

An A/D conversion is started by writing into the SFR ADDATL with dummy data. A write to SFR ADDATL will start a new conversion even if a conversion is currently in progress. The conversion begins with the next machine cycle, and the BSY flag in SFR ADCON0 will be set.

The A/D conversion procedure is divided into three parts :

- Sample phase (t_S), used for sampling the analog input voltage.
- Conversion phase (t_{CO}), used for the real A/D conversion (includes calibration).
- Write result phase (t_{WR}), used for writing the conversion result into the ADDAT registers.

The total A/D conversion time is defined by t_{ADCC} which is the sum of the two phase times t_S and t_{CO} . The duration of the three phases of an A/D conversion is specified by their corresponding timing parameter as shown in **figure 3-3**.

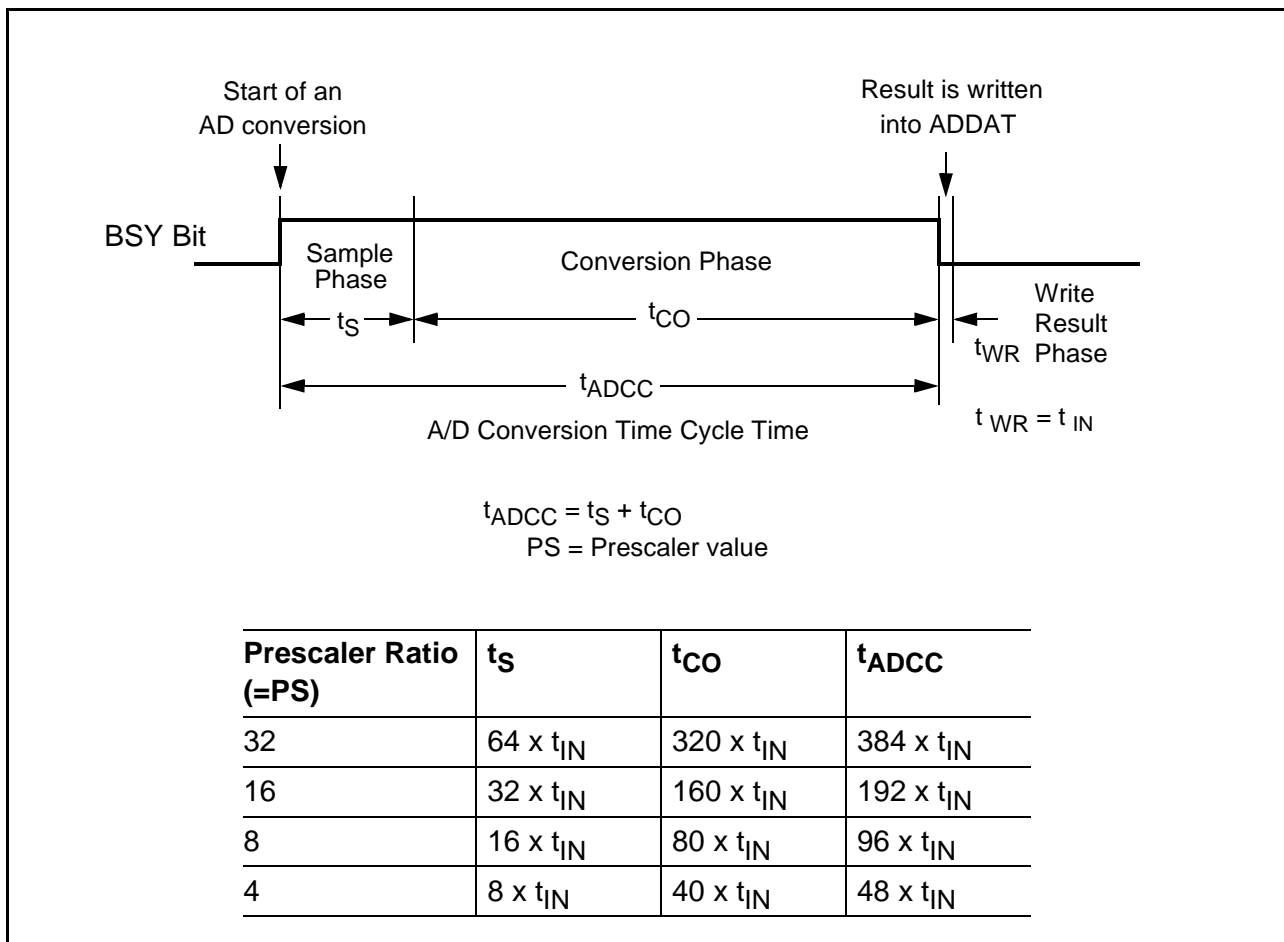

Figure 3-3
A/D Conversion Timing

Sample Time t_S :

During this time the internal capacitor array is connected to the selected analog input channel and is loaded with the analog voltage to be converted. The analog voltage is internally fed to a voltage comparator. With beginning of the sample phase the BSY bit in SFR ADCON0 is set.

Conversion Time t_{CO} :

During the conversion time the analog voltage is converted into a 10-bit digital value using the successive approximation technique with a binary weighted capacitor network. During an A/D conversion also a calibration takes place. During this calibration alternating offset and linearity calibration cycles are executed (see also section 3.5). At the end of the calibration time the BSY bit is reset and the IADC bit in SFR IRCON is set indicating an A/D converter interrupt condition.

Write Result Time t_{WR} :

At the result phase the conversion result is written into the ADDAT registers.

Figure 3-4 shows how an A/D conversion is embedded into the microcontroller cycle scheme using the relation $6 \times t_{IN} = 1$ instruction cycle. It also shows the behaviour of the busy flag (BSY) and the interrupt flag (IADC) during an A/D conversion.

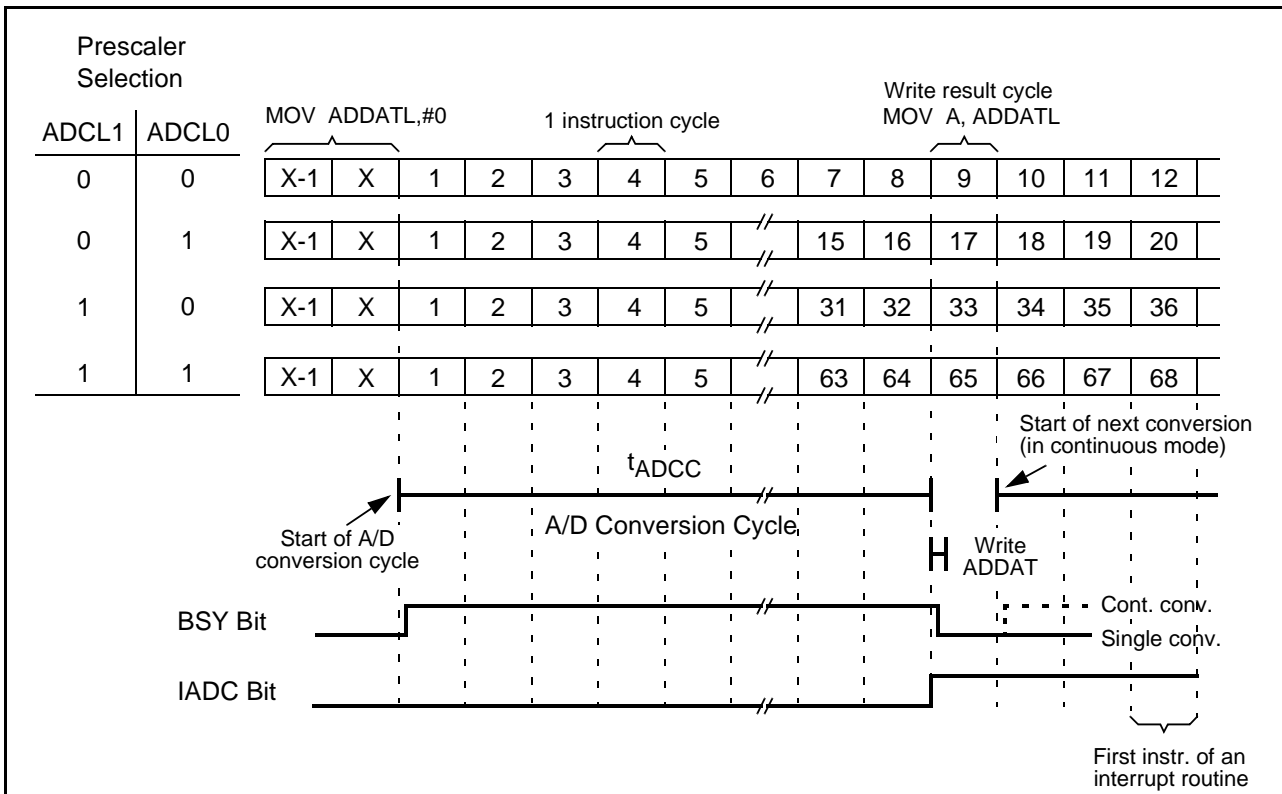

Figure 3-4
A/D Conversion Timing in Relation to Processor Cycles

Depending on the selected prescaler ratio (see figure 3-2), four different relationships between machine cycles and A/D conversion are possible. The A/D conversion is started when SFR ADDATL is written with dummy data. This write operation may take one or two machine cycles. In figure 3-4, the instruction MOV ADDATL,#0 starts the A/D conversion (machine cycle X-1 and X). The total A/D conversion (sample, conversion, and calibration phase) is finished with the end of the 8th, 16th, 32nd, or 64th machine cycle after the A/D conversion start. In the next machine cycle the conversion result is written into the ADDAT registers and can be read in the same cycle by an instruction (e.g. MOV A,ADDATL). If continuous conversion is selected (bit ADM set), the next conversion is started with the beginning of the machine cycle which follows the write result cycle.

The BSY bit is set at the beginning of the first A/D conversion machine cycle and reset at the beginning of the write result cycle. If continuous conversion is selected, BSY is again set with the beginning of the machine cycle which follows the write result cycle.

The interrupt flag IADC is set at the end of the A/D conversion. If the A/D converter interrupt is enabled and the A/D converter interrupt is prioritized to be serviced immediately, the first instruction of the interrupt service routine will be executed in the third machine cycle which follows the write result cycle. IADC must be reset by software.

Depending on the application, typically there are three methods to handle the A/D conversion in the C505A.

- Software delay
The machine cycles of the A/D conversion are counted and the program executes a software delay (e.g. NOPs) before reading the A/D conversion result in the write result cycle. This is the fastest method to get the result of an A/D conversion.
- Polling BSY bit
The BSY bit is polled and the program waits until BSY=0. Attention : a polling JB instruction which is two machine cycles long, possibly may not recognize the BSY=0 condition during the write result cycle in the continuous conversion mode.
- A/D conversion interrupt
After the start of an A/D conversion the A/D converter interrupt is enabled. The result of the A/D conversion is read in the interrupt service routine. If other C505A interrupts are enabled, the interrupt latency must be regarded. Therefore, this software method is the slowest method to get the result of an A/D conversion.

Depending on the oscillator frequency of the C505A and the selected divider ratio of the conversion clock prescaler the total time of an A/D conversion is calculated according **figure 3-3** and **table 3-1**. **Figure 3-5** on the next page shows the minimum A/D conversion time in relation to the oscillator frequency f_{OSC} . The minimum conversion time is 6 μs and can be achieved at f_{OSC} of 8 or 16 MHz (or whenever $f_{ADC} = 2$ MHz).

Table 4-1
A/D Conversion Time for Dedicated System Clock Rates

f_{OSC} [MHz]	Prescaler Ratio PS	f_{ADC} [MHz]	Sample Time t_S [μs]	Total Conversion Time t_{ADCC} [μs]
2 MHz	÷ 4	0.5	4	24
6 MHz	÷ 4	1.5	1.33	8
8 MHz	÷ 4	2	1	6
12 MHz	÷ 8	1.5	1.33	8
16 MHz	÷ 8	2	1	6
20 MHz	÷ 16	1.25	1.6	9.6

Note : The prescaler ratios in **table 3-1** are minimum values.

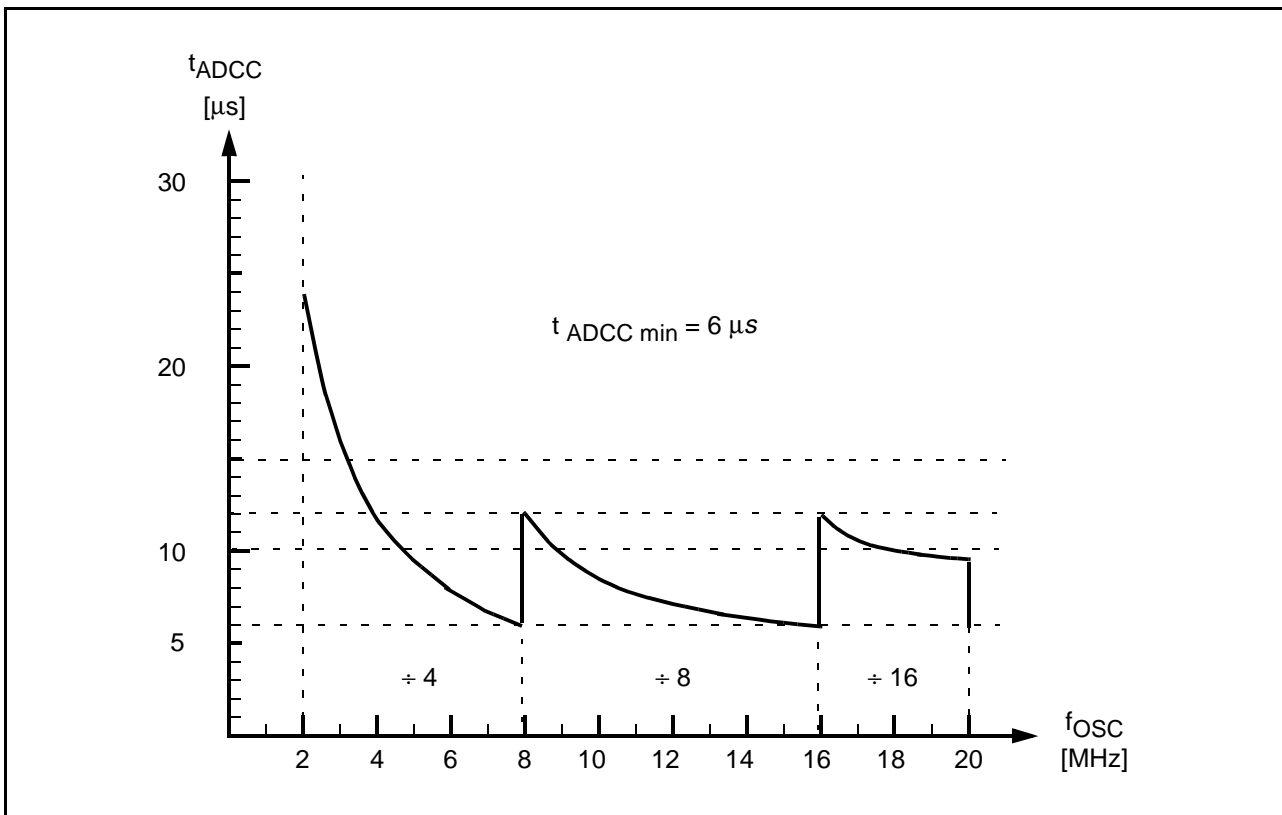

Figure 3-5
Minimum A/D Conversion Time in Relation to System Clock

3.5 A/D Converter Calibration

The C505A A/D converter includes hidden internal calibration mechanisms which assure a safe functionality of the A/D converter according to the DC characteristics. The A/D converter calibration is implemented in a way that a user program which executes A/D conversions is not affected by its operation. Further, the user program has no control over the calibration mechanism. The calibration itself executes two basic functions :

- Offset calibration : correction of offset errors of comparator and the capacitor network
- Linearity calibration : correction of the binary weighted capacitor network

The A/D converter calibration operates in two phases : calibration after a reset operation and calibration at each A/D conversion. The calibration phases are controlled by a state machine in the A/D converter. This state machine executes the calibration phases and stores the calibration results dynamically in a small calibration RAM.

After a reset operation the A/D calibration is automatically started. This reset calibration phase which takes $3328 f_{ADC}$ clocks, alternating offset and linearity calibration is executed. Therefore, at 8 MHz oscillator frequency and with the default after reset prescaler value of 4, a reset calibration time of approx. 1.66 ms is reached. For achieving a proper reset calibration, the f_{ADC} prescaler value must satisfy the condition $f_{ADC\ max} \leq 2\ \text{MHz}$. If this condition is not met at a specific oscillator frequency with the default prescaler value after reset, the f_{ADC} prescaler must be adjusted immediately after reset by setting bits ADCL1 and ADCL0 in SFR ADCON1 to a suitable value. It is also recommended to have the proper voltages, as specified in the DC specifications, applied at the V_{AREF} and V_{AREF} pins before the reset calibration has started.

After the reset calibration phase the A/D converter is calibrated according to its DC characteristics. Nevertheless, during the reset calibration phase single or continuous A/D can be executed. In this case it must be regarded that the reset calibration is interrupted and continued after the end of the A/D conversion. Therefore, interrupting the reset calibration phase by A/D conversions extends the total reset calibration time. If the specified total unadjusted error (TUE) has to be valid for an A/D conversion, it is recommended to start the first A/D conversions after reset when the reset calibration phase is finished. Depending on the oscillator frequency used, the reset calibration phase can be possibly shortened by setting ADCL1 and ADCL0 (prescaler value) to its final value immediately after reset.

After the reset calibration, a second calibration mechanism is initiated. This calibration is coupled to each A/D conversion. With this second calibration mechanism alternatively offset and linearity calibration values, stored in the calibration RAM, are always checked when an A/D conversion is executed and corrected if required.

3.5.1 A/D Converter Analog Input Selection

The analog inputs are located at port 1. The corresponding pins have a port structure, which allows to use them either as digital I/O pins or as analog inputs (see section 6.1.3.2). The analog input function of these digital/analog port lines are selected via the register P1ANA. This register lies in the mapped SFR area and can be accessed when bit RMAP in SFR SYSCON is set when writing to its address (90_H). If a specific bit location of P1ANA is set, the corresponding port line is configured as a digital input. With a 0 in the bit location the port line operates as analog port.

Special Function Registers P1ANA (Address 90_H)

Reset Value : FF_H

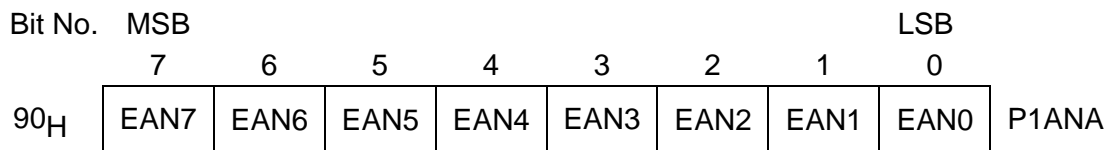

Bit	Function
EAN7 - EAN0	Enable analog port 1 inputs If EANx (x = 7-0) is cleared, port pin P1.x is enabled for operation as an analog input. If EANx is set, port pin P1.x is enabled for digital I/O function (default after reset).

4 OTP Memory Operation

The C505A-4E is the OTP version in the C505A microcontroller with a 32K byte one-time programmable (OTP) program memory. With the C505A-4E fast programming cycles are achieved (1 byte in 100 μsec). Also several levels of OTP memory protection can be selected. The basic functionality of the C505A-4E as microcontroller is identical to the C505A-L (romless part) functionality.

4.1 Programming Configuration

During normal program execution the C505A-4E behaves like the C505A-L. For programming the device, the C505A-4E must be put into the programming mode. This, typically, is done not in-system but in a special programming hardware. In the programming mode the C505A-4E operates as a slave device similar as an EPROM standalone memory device and must be controlled with address/data information, control lines, and an external 11.5 V programming voltage.

In the programming mode port 0 provides the bidirectional data lines and port 2 is used for the multiplexed address inputs. The upper address information at port 2 is latched with the signal PALE. For basic programming mode selection the inputs RESET, \overline{PSEN} , \overline{EA}/V_{PP} , ALE and PMSEL1/0 and \overline{PSEL} are used. Further, the inputs PMSEL1,0 are required to select the access types (e.g. program/verify data, write lock bits, ...) in the programming mode. In programming mode V_{CC}/V_{SS} and a clock signal at the XTAL pins must be applied to the C505A-4E. The 11.5 V external programming voltage is input through the \overline{EA}/V_{PP} pin.

Figure 4-1 shows the pins of the C505A-4E which are required for controlling of the OTP programming mode.

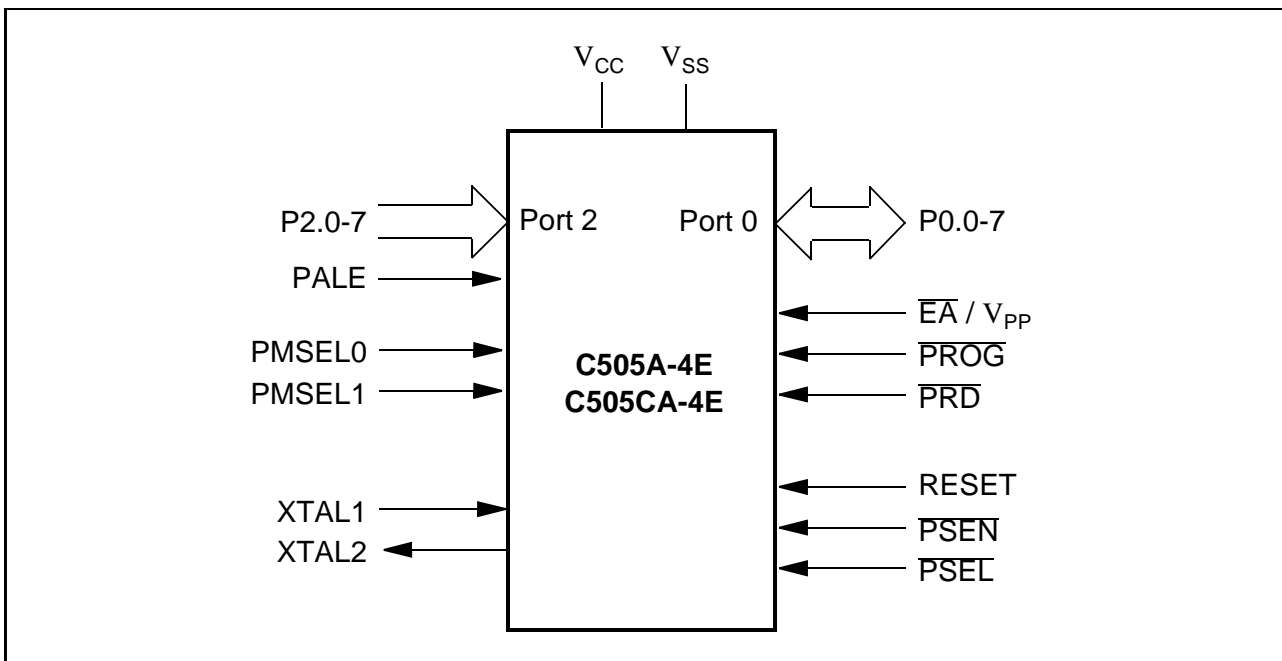

Figure 4-1
Programming Mode Configuration

4.2 Pin Configuration

Figure 4-2 shows the detailed pin configuration of the C505A-4E in programming mode.

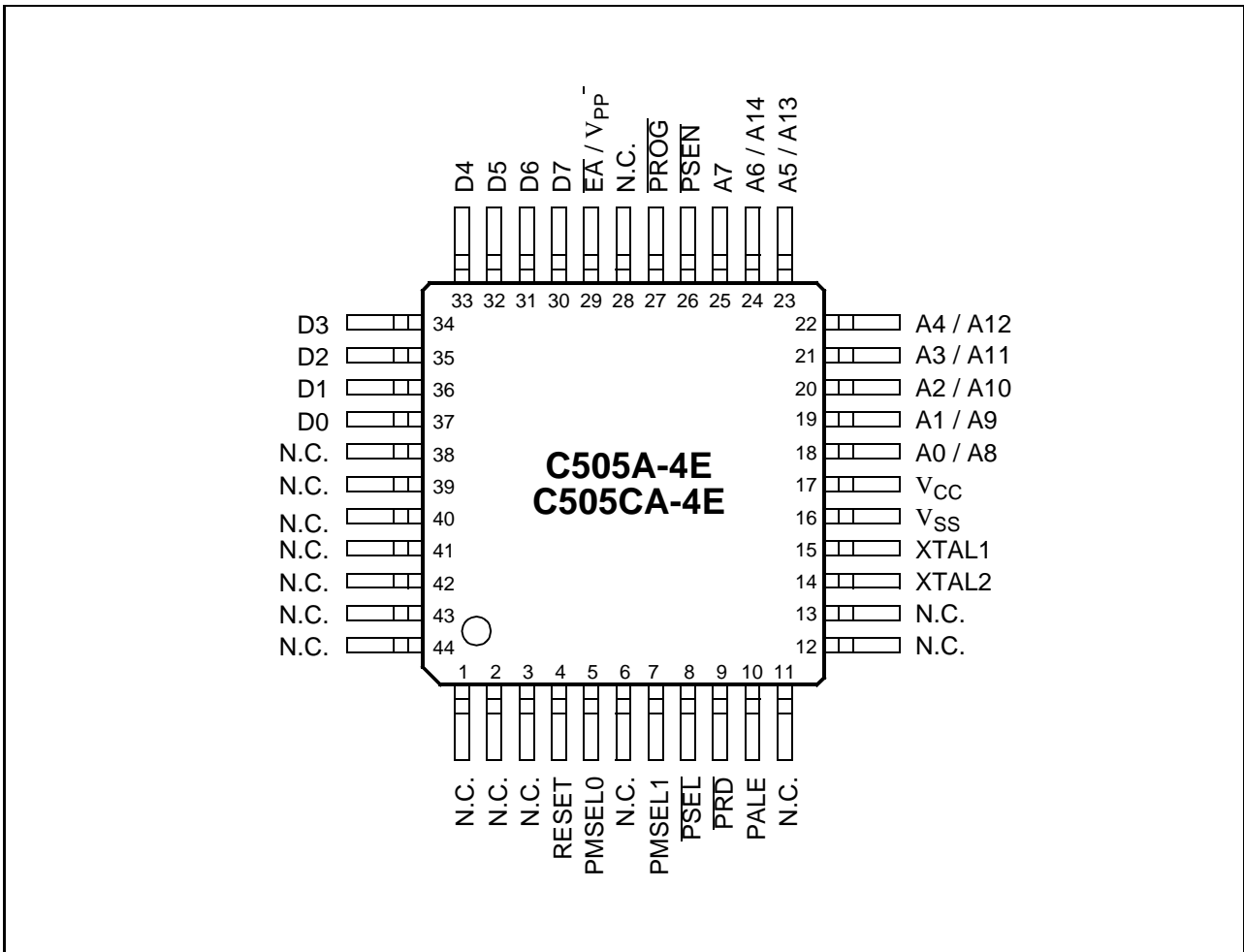

Figure 4-2
OTP Programming Mode Pin Configuration (Top View)

4.3 Pin Definitions

The following **figure 4-1** contains the functional description of all C505A-4E pins which are required for OTP memory programming

Table 4-1
Pin Definitions and Functions of the C505A-4E in Programming Mode

Symbol	Pin Number	I/O *)	Function															
	P-MQFP-44																	
RESET	4	I	Reset This input must be at static "1" (active) level during the whole programming mode.															
PMSEL0 PMSEL1	5 7	I I	Programming mode selection pins These pins are used to select the different access modes in programming mode. PMSEL1,0 must satisfy a setup time to the rising edge of PALE. When the logic level of PMSEL1,0 is changed, PALE must be at low level. <table border="1" style="margin-top: 10px;"> <thead> <tr> <th>PMSEL1</th> <th>PMSEL0</th> <th>Access Mode</th> </tr> </thead> <tbody> <tr> <td>0</td> <td>0</td> <td>Reserved</td> </tr> <tr> <td>0</td> <td>1</td> <td>Read signature bytes</td> </tr> <tr> <td>1</td> <td>0</td> <td>Program/read lock bits</td> </tr> <tr> <td>1</td> <td>1</td> <td>Program/read OTP memory byte</td> </tr> </tbody> </table>	PMSEL1	PMSEL0	Access Mode	0	0	Reserved	0	1	Read signature bytes	1	0	Program/read lock bits	1	1	Program/read OTP memory byte
PMSEL1	PMSEL0	Access Mode																
0	0	Reserved																
0	1	Read signature bytes																
1	0	Program/read lock bits																
1	1	Program/read OTP memory byte																
PSEL	8	I	Basic programming mode select This input is used for the basic programming mode selection and must be switched according figure 4-3 .															
PRD	9	I	Programming mode read strobe This input is used for read access control for OTP memory read, version byte read, and lock bit read operations.															
PALE	10	I	Programming address latch enable PALE is used to latch the high address lines. The high address lines must satisfy a setup and hold time to/from the falling edge of PALE. PALE must be at low level when the logic level of PMSEL1,0 is changed.															
XTAL2	14	O	XTAL2 Output of the inverting oscillator amplifier.															
XTAL1	15	I	XTAL1 Input to the oscillator amplifier.															

*) I = Input
O = Output

Table 4-1
Pin Definitions and Functions of the C505A-4E in Programming Mode (cont'd)

Symbol	Pin Number	I/O *)	Function
	P-MQFP-44		
V_{SS}	16	–	Circuit ground potential must be applied in programming mode.
V_{CC}	17	–	Power supply terminal must be applied in programming mode.
P2.0-7	18-25	I	Address lines P2.0-7 are used as multiplexed address input lines A0-A7 and A8-A14. A8-A14 must be latched with PALE.
\overline{PSEN}	26	I	Program store enable This input must be at static "0" level during the whole programming mode.
\overline{PROG}	27	I	Programming mode write strobe This input is used in programming mode as a write strobe for OTP memory program, and lock bit write operations During basic programming mode selection a low level must be applied to \overline{PROG} .
\overline{EA}/V_{PP}	29	–	Programming voltage This pin must be at 11.5 V (V_{PP}) voltage level during programming of an OTP memory byte or lock bit. During an OTP memory read operation this pin must be at V_{IHx} high level. This pin is also used for basic programming mode selection. At basic programming mode selection a low level must be applied to \overline{EA}/V_{PP} .
P0.7-0	30-37	I/O	Data lines 0-7 During programming mode, data bytes are transferred via the bidirectional D7-0 lines which are located at port 0.
N.C.	1-3, 6, 11-13, 28, 38-44	–	Not Connected These pins should not be connected in programming mode.

*) I = Input
O = Output

4.4 Programming Mode Selection

The selection for the OTP programming mode can be separated into two different parts :

- Basic programming mode selection
- Access mode selection

With the basic programming mode selection the device is put into the mode in which it is possible to access the OTP memory through the programming interface logic. Further, after selection of the basic programming mode, OTP memory accesses are executed by using one of the access modes. These access modes are OTP memory byte program/read, version byte read, and program/read lock byte operations.

4.4.1 Basic Programming Mode Selection

The basic programming mode selection scheme is shown in **figure 4-3**.

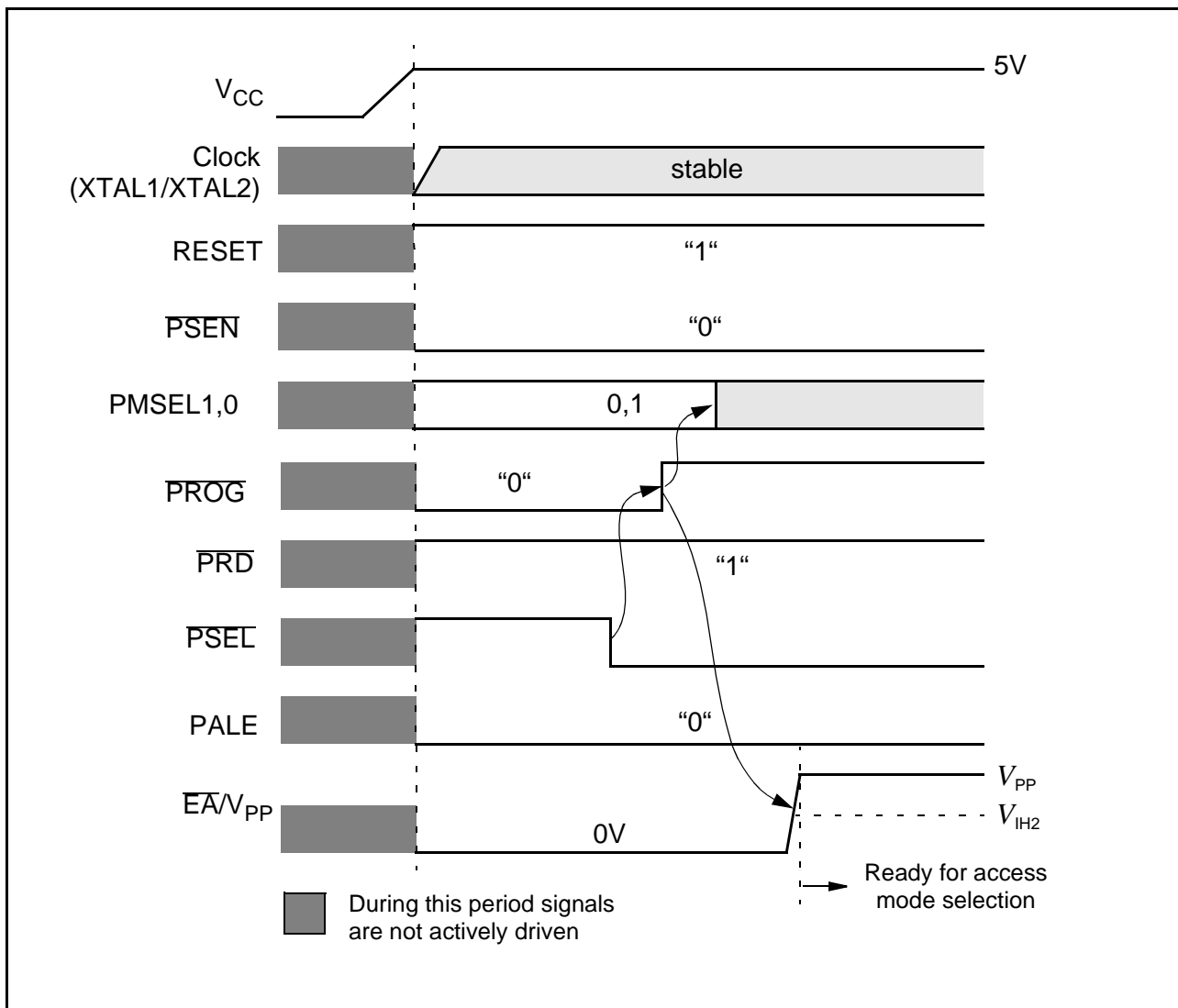

Figure 4-3
Basic Programming Mode Selection

The basic programming mode is selected by executing the following steps :

- With a stable V_{CC} a clock signal is applied to the XTAL pins; the RESET pin is set to “1” level and the \overline{PSEN} pin is set to “0” level.
- \overline{PROG} , PALE, PMSEL1 and \overline{EA}/V_{PP} are set to “0” level; \overline{PRD} , \overline{PSEL} , and PMSEL0 are set to “1” level.
- \overline{PSEL} is switched from “1” to “0” level and thereafter \overline{PROG} is switched to “1” level.
- PMSEL1,0 can now be changed; after \overline{EA}/V_{PP} has been set to V_{IHx} high level or to V_{PP} the OTP memory is ready for access.

The pins RESET and \overline{PSEN} must stay at “1” respectively “0” static signal level during the whole programming mode. With a falling edge of \overline{PSEL} the logic state of \overline{PROG} and \overline{EA}/V_{PP} is internally latched. These two signals are now used as programming write pulse signal (\overline{PROG}) and as programming voltage input pin V_{PP} . After the falling edge of \overline{PSEL} , \overline{PSEL} must stay at “0” state during all programming operations.

Note: If protection level 1 to 3 has been programmed (see section 4.6) and the programming mode has been left, it is no more possible to enter the programming mode !

4.4.2 OTP Memory Access Mode Selection

When the C505A-4E has been put into the programming mode using the basic programming mode selection, several access modes of the OTP memory programming interface are available. The conditions for the different control signals of these access modes are listed in **table 4-2**.

Table 4-2
Access Modes Selection

Access Mode	\overline{EA}/V_{PP}	PROG	PRD	PMSEL		Address (Port 2)	Data (Port 0)
				1	0		
Program OTP memory byte	V_{PP}		H	H	H	A0-7	D0-7
Read OTP memory byte	V_{IHx}	H		H	H	A8-14	
Program OTP lock bits	V_{PP}		H	H	L	–	D1,D0 see table 4-3
Read OTP lock bits	V_{IHx}	H		H	H		
Read OTP version byte	V_{IHx}	H		L	H	Byte addr. of version byte	D0-7

The access modes from the table above are basically selected by setting the two PMSEL1,0 lines to the required logic level. The \overline{PROG} and \overline{PRD} signal are the write and read strobe signal. Data is transferred via port 0 and addresses are applied to port 2.

The following sections describes the details of the different access modes.

4.5 Program / Read OTP Memory Bytes

The program/read OTP memory byte access mode is defined by PMSEL1,0 = 1,1. It is initiated when the PMSEL1,0 = 1,1 is valid at the rising edge of PALE. With the falling edge of PALE the upper addresses A8-A14 of the 15-bit OTP memory address are latched. After A8-A14 has been latched, A0-A7 is put on the address bus (port 2). A0-A7 must be stable when $\overline{\text{PROG}}$ is low or $\overline{\text{PRD}}$ is low. If subsequent OTP address locations are accessed with constant address information at the high address lines A8-14, A8-A14 must only be latched once (page address mechanism).

Figure 4-4 shows a typical basic OTP memory programming cycle with a following OTP memory read operation. In this example A0-A14 of the read operation are identical to A8-A14 of the preceding programming operation.

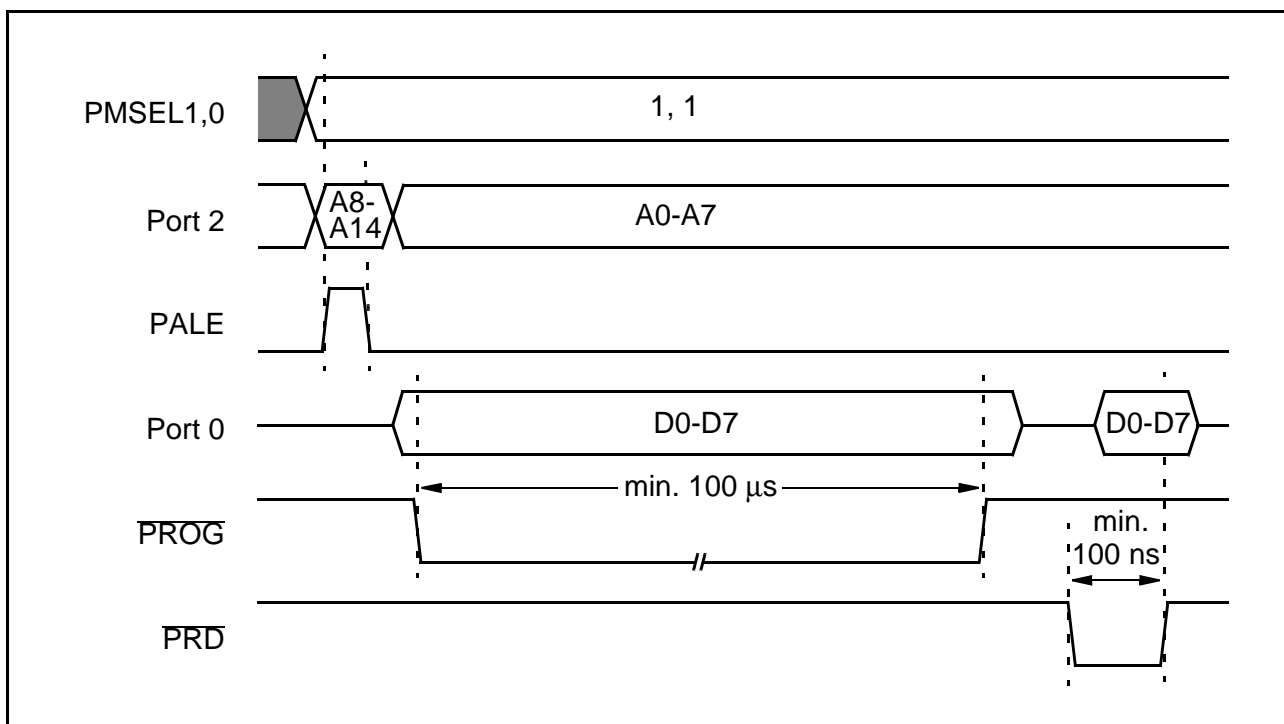

Figure 4-4 Programming / Verify OTP Memory Access Waveform

If the address lines A8-A14 must be updated, PALE must be activated for the latching of the new A8-A14 value. Control, address, and data information must only be switched when the $\overline{\text{PROG}}$ and $\overline{\text{PRD}}$ signals are at high level. The PALE high pulse must always be executed if a different access mode has been used prior to the actual access mode.

Figure 4-5 shows a waveform example of the program/read mode access for several OTP memory bytes. In this example OTP memory locations 3FD_H to 400_H are programmed. Thereafter, OTP memory locations 400_H and 3FD_H are read.

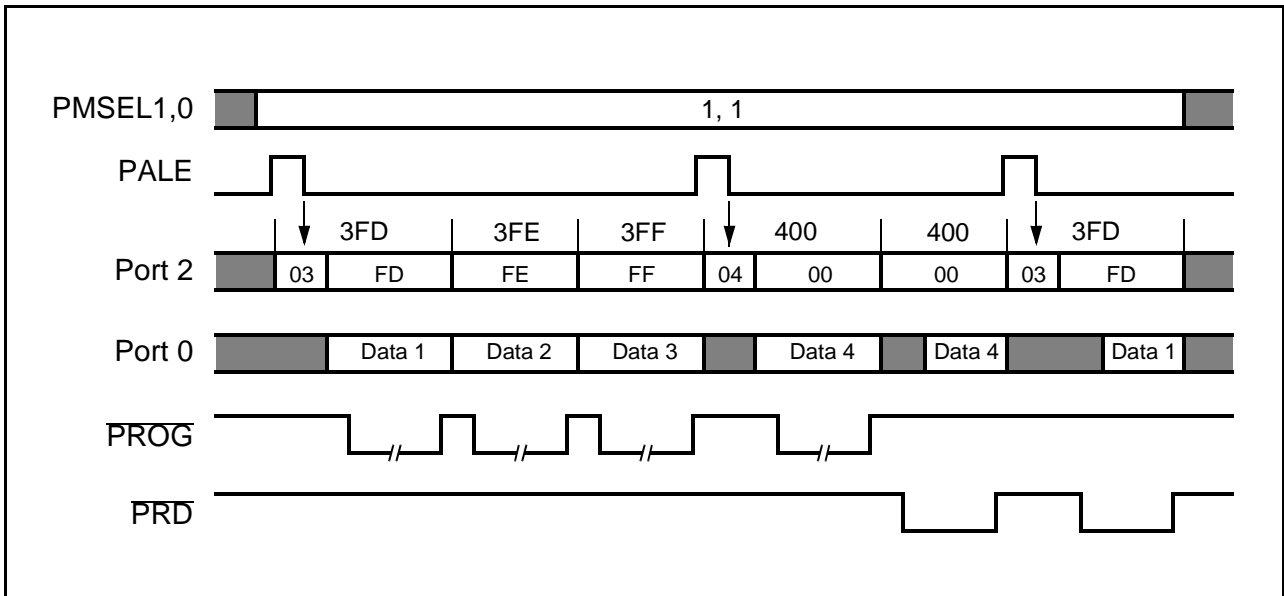

Figure 4-5
Typical OTP Memory Programming/Verify Access Waveform

4.6 Lock Bits Programming / Read

The C505A-4E has two programmable lock bits which, when programmed according **table 4-3**, provide four levels of protection for the on-chip OTP code memory.

**Table 4-3
Lock Bit Protection Types**

Lock Bits at D1,D0		Protection Level	Protection Type
D1	D0		
1	1	Level 0	The OTP lock feature is disabled. During normal operation of the C505A-4E, the state of the \overline{EA} pin is not latched on reset.
1	0	Level 1	During normal operation of the C505A-4E, MOV _C instructions executed from external program memory are disabled from fetching code bytes from internal memory. \overline{EA} is sampled and latched on reset. An OTP memory read operation is only possible according to OTP verification mode. Further programming of the OTP memory is disabled (reprogramming security).
0	1	Level 2	Same as level 1, but also OTP memory read operation using OTP verification mode is disabled.
0	0	Level 3	Same as level 2; but additionally external code execution by setting \overline{EA} =low during normal operation of the C505A-4E is no more possible. External code execution, which is initiated by an internal program (e.g. by an internal jump instruction above the OTP memory boundary), is still possible.

Note : A 1 means that the lock bit is unprogrammed. 0 means that lock bit is programmed.

For a OTP verify operation at protection level 1, the C505A-4E must be put into the OTP verification mode.

If a device is programmed with protection level 2 or 3, it is no longer possible to verify the OTP content of a customer rejected (FAR) OTP device.

When a protection level has been activated by programming of the lock bits, the basic programming mode must be left for activation of the protection mechanisms. This means, after the activation of a protection level further OTP program/verify operations are still possible if the basic programming mode is maintained.

The state of the lock bits can always be read if protection level 0 is selected. If protection level 1 to 3 has been programmed and the programming mode has been left, it is not possible to re-enter the programming mode. In this case, the lock bits cannot be read anymore.

Figure 4-6 shows the waveform of a lock bit write/read access. For a simple drawing, the \overline{PROG} pulse is shortened. In reality, for lock bit programming, a 100µs \overline{PROG} low pulse must be applied.

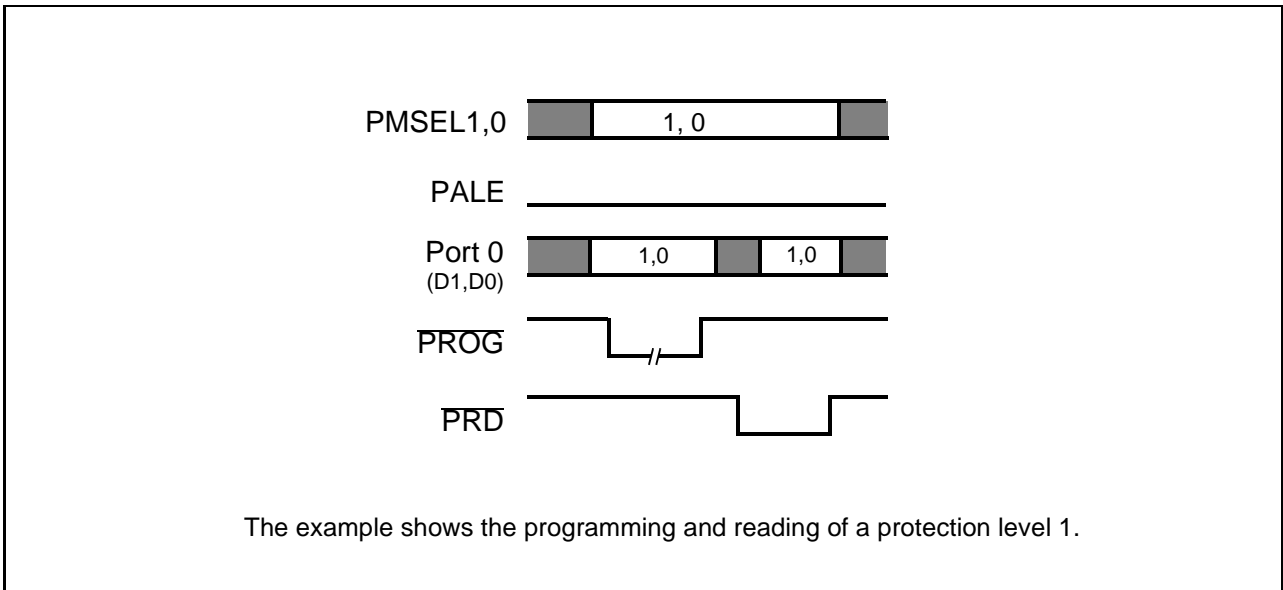

**Figure 4-6
Write/Read Lock Bit Waveform**

4.6.1 Access of Version Bytes

The C505A-4E and C505CA-4E provide three version bytes at address locations FC_H, FD_H, and FE_H. The information stored in the version bytes, is defined by the mask of each microcontroller step. Therefore, the version bytes can be read but not written. The three Version Registers hold information as manufacturer code, device type, and stepping code.

For reading of the version bytes the control lines must be used according **table 4-2** and **figure 4-7**. The address of the version byte must be applied at the port 1 address lines. PALE must not be activated.

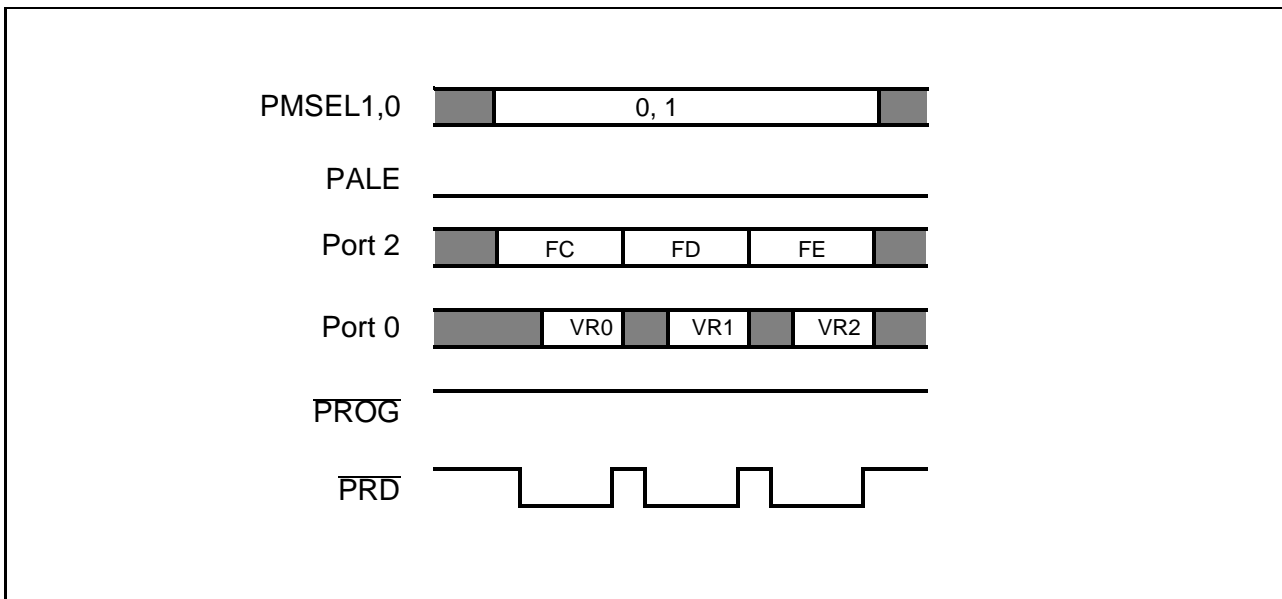

Figure 4-7
Read Version Register(s) Waveform

Version bytes are typically used by programming systems for adapting the programming firmware to specific device characteristics such as OTP size etc.

Note: The 3 version bytes are implemented in a way that they can be also be read during normal program execution mode as a mapped register with bit RMAP in SFR SYSCON set. The addresses of the version bytes in normal mode and programming mode are identical and therefore they are located in the SFR address range.

The steppings of the C505A versions will contain the following version byte information :

Stepping	Version Byte 0 = VR0 (mapped addr. FC _H)	Version Byte 1 = VR1 (mapped addr. FD _H)	Version Byte 2 = VR2 (mapped addr. FE _H)
ES-AA Steps of C505A-4E and C505CA-4E	C5 _H	05 _H	11 _H

Note:

Future steppings of C505A would have a different version byte 2 content.

4.7 OTP Verification Mode

The OTP verification mode as shown in **figure 4-8** is used to verify the contents of the OTP when the protection level 1 has been set. The detailed timing characteristics of the OTP verification mode are shown in the AC specifications (chapter 5).

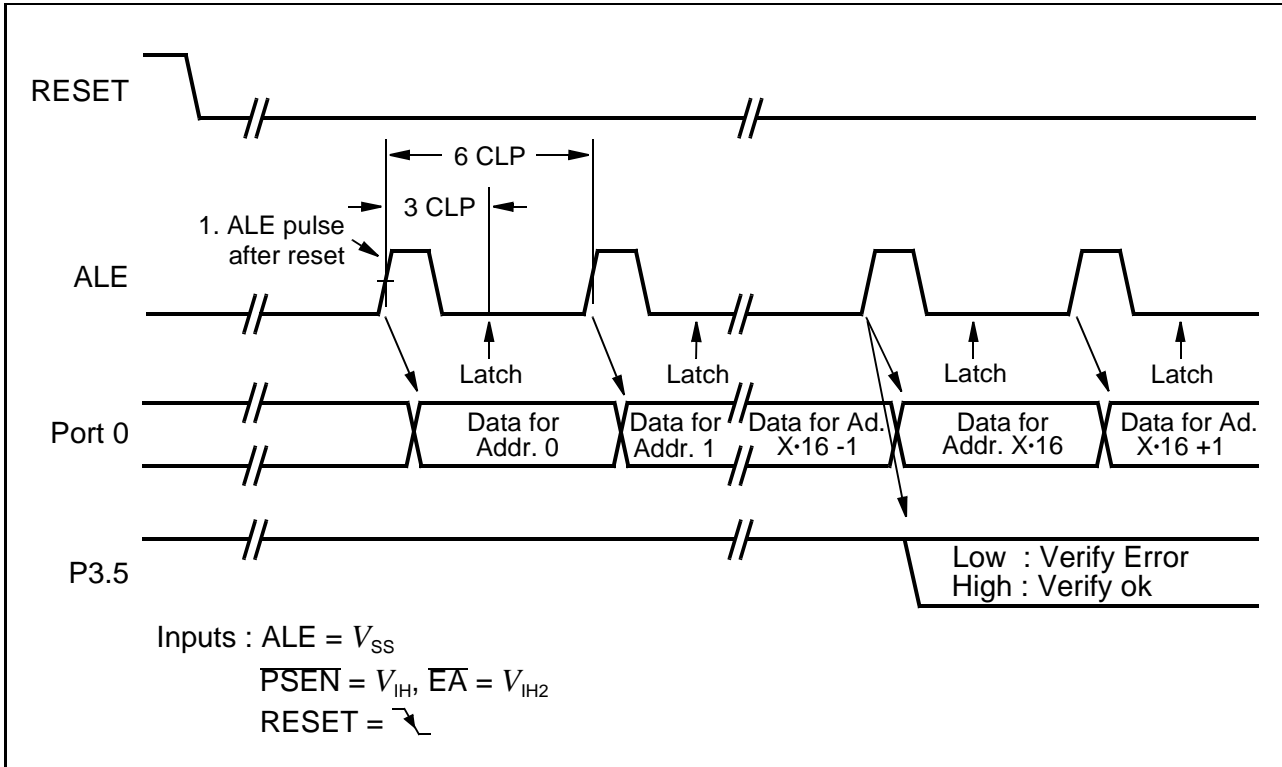

Figure 4-8
OTP Verification Mode

OTP verification mode is selected if the inputs \overline{PSEN} , \overline{EA} , and ALE are put to the specified logic levels. With RESET going inactive, the OTP verification mode sequence is started. The C505A-4E outputs an ALE signal with a period of 3 CLP and expects data bytes at port 0. The data bytes at port 0 are assigned to the OTP addresses in the following way :

- 1. Data Byte = content of OTP address 0000_H
- 2. Data Byte = content of OTP address 0001_H
- 3. Data Byte = content of OTP address 0002_H
- :
- 16. Data Byte = content of OTP address 000F_H
- :

The C505A-4E does not output any address information during the OTP verification mode. The first data byte to be verified is always the byte which is assigned to the OTP address 0000_H and must be put onto the data bus with the falling edge of RESET. With each following ALE pulse the OTP address pointer is internally incremented and the expected data byte for the next OTP address must be delivered externally.

Between two ALE pulses the data at port 0 is latched (at 3 CLP after ALE rising edge) and compared internally with the OTP content of the actual address. If a verify error is detected, the error condition

is stored internally. After each 16th data byte the cumulated verify result (pass or fail) of the last 16 verify operations is output at P3.5. This means that P3.5 stays at static level (low for fail and high for pass) during the time when the following 16 bytes are checked. In OTP verification mode, the C505A-4E must be provided with a system clock at the XTAL pins.

Figure 4-9 shows an application example of an external circuitry which allows to verify the OTP, with protection level 1, inside the C505A-4E in the OTP verification mode. With RESET going inactive, the C505A-4E starts the OTP verify sequence. Its ALE is clocking a 15-bit address counter. This counter generates the addresses for an external EPROM which is programmed with the contents of the OTP. The verify detect logic typically displays the pass/fail information of the verify operation. P3.5 can be latched with the falling edge of ALE.

When the last byte of the OTP has been handled, the C505A-4E starts generating a PSEN signal. This signal or the CY signal of the address counter indicate to the verify detect logic the end of the OTP verification.

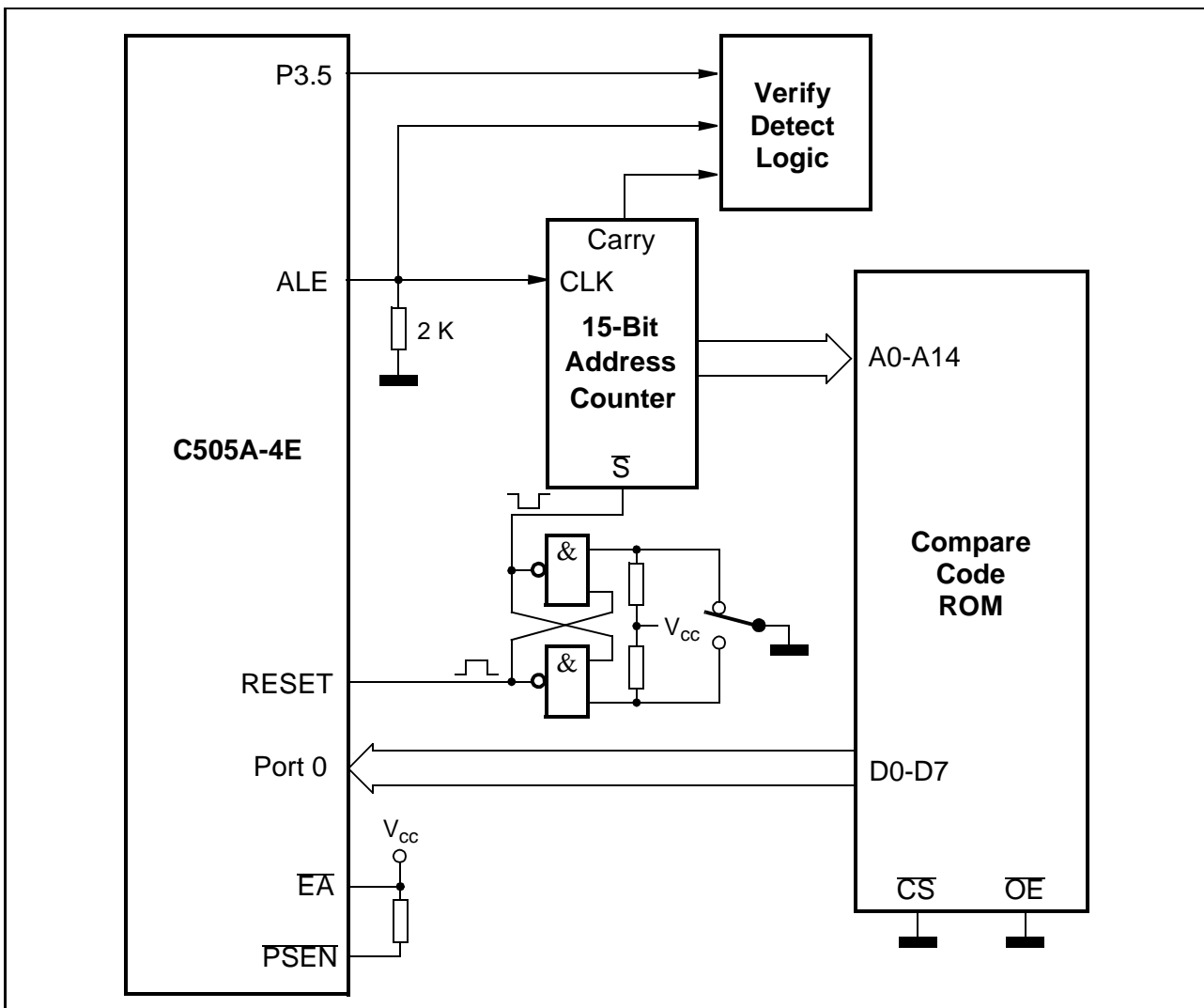

Figure 4-9
OTP Verification Mode - External Circuitry Example

5 Device Specifications

5.1 Absolute Maximum Ratings

Ambient temperature under bias (T_A)	- 40 °C to + 125 °C
Storage temperature (T_{ST}).....	- 65 °C to + 150 °C
Voltage on V_{CC} pins with respect to ground (V_{SS})	- 0.5 V to 6.5 V
Voltage on any pin with respect to ground (V_{SS})	- 0.5 V to $V_{CC} + 0.5$ V
Input current on any pin during overload condition.....	- 10 mA to + 10 mA
Absolute sum of all input currents during overload condition	100 mA
Power dissipation.....	TBD

Note:

Stresses above those listed under “Absolute Maximum Ratings” may cause permanent damage of the device. This is a stress rating only and functional operation of the device at these or any other conditions above those indicated in the operational sections of this specification is not implied. Exposure to absolute maximum rating conditions for longer periods may affect device reliability. During overload conditions ($V_{IN} > V_{CC}$ or $V_{IN} < V_{SS}$) the Voltage on V_{CC} pins with respect to ground (V_{SS}) must not exceed the values defined by the absolute maximum ratings.

5.2 DC Characteristics

$V_{CC} = 5V +10\%, -15\%$; $V_{SS} = 0 V$

$T_A = 0$ to $70\text{ }^\circ\text{C}$

$T_A = -40$ to $85\text{ }^\circ\text{C}$

$T_A = -40$ to $110\text{ }^\circ\text{C}$

$T_A = -40$ to $125\text{ }^\circ\text{C}$

for the SAB- versions

for the SAF- versions

for the SAH- versions

for the SAK- versions

Parameter	Symbol	Limit Values		Unit	Test Condition
		min.	max.		
Input low voltages all except \overline{EA} , RESET	V_{IL}	- 0.5	$0.2 V_{CC} - 0.1$	V	-
\overline{EA} pin	V_{IL1}	- 0.5	$0.2 V_{CC} - 0.3$	V	-
RESET pin	V_{IL2}	- 0.5	$0.2 V_{CC} + 0.1$	V	-
Input high voltages all except XTAL1, RESET	V_{IH}	$0.2 V_{CC} + 0.9$	$V_{CC} + 0.5$	V	-
XTAL1 pin	V_{IH1}	$0.7 V_{CC}$	$V_{CC} + 0.5$	V	-
RESET pin	V_{IH2}	$0.6 V_{CC}$	$V_{CC} + 0.5$	V	-
Output low voltages Ports 1, 2, 3, 4	V_{OL}	-	0.45	V	$I_{OL} = 1.6\text{ mA}^1$
Port 0, ALE, \overline{PSEN}	V_{OL1}	-	0.45	V	$I_{OL} = 3.2\text{ mA}^1$
Output high voltages Ports 1, 2, 3, 4	V_{OH}	2.4	-	V	$I_{OH} = -80\text{ }\mu\text{A}$
		$0.9 V_{CC}$	-	V	$I_{OH} = -10\text{ }\mu\text{A}$
Port 0 in external bus mode, ALE, \overline{PSEN}	V_{OH2}	2.4	-	V	$I_{OH} = -800\text{ }\mu\text{A}$
		$0.9 V_{CC}$	-	V	$I_{OH} = -80\text{ }\mu\text{A}^2$
Logic 0 input current Ports 1, 2, 3, 4	I_{IL}	- 10	- 70	μA	$V_{IN} = 0.45\text{ V}$
Logical 0-to-1 transition current Ports 1, 2, 3, 4	I_{TL}	- 65	- 650	μA	$V_{IN} = 2\text{ V}$
Input leakage current Port 0, AN0-7 (Port 1), \overline{EA}	I_{LI}	-	± 1	μA	$0.45 < V_{IN} < V_{CC}$
Pin capacitance	C_{IO}	-	10	pF	$f_c = 1\text{ MHz}$, $T_A = 25\text{ }^\circ\text{C}$
Overload current	I_{OV}	-	± 5	mA	^{3) 4)}
Programming voltage	V_{PP}	10.9	12.1	V	$11.5\text{ V} \pm 5\%^5$
Supply current at \overline{EA}/V_{CC}			30	mA	⁵⁾

Notes see next page

Power Supply Current

Parameter			Symbol	Limit Values		Unit	Test Condition
				typ. ¹¹⁾	max. ¹²⁾		
C505A	Active Mode	12 MHz	I_{CC}	TBD	TBD	mA	6)
		20 MHz	I_{CC}	TBD	TBD		
	Idle Mode	12 MHz	I_{CC}	TBD	TBD	mA	7)
		20 MHz	I_{CC}	TBD	TBD		
	Active Mode with slow-down enabled	12 MHz 20 MHz	I_{CC} I_{CC}	TBD TBD	TBD TBD	mA	8)
Idle Mode with slow-down enabled	12 MHz 20 MHz	I_{CC} I_{CC}	TBD TBD	TBD TBD			
Power down current		I_{PD}	TBD	60	μA	$V_{CC} = 2..5.5 V$ ¹⁰⁾	

Notes :

- 1) Capacitive loading on ports 0 and 2 may cause spurious noise pulses to be superimposed on the V_{OL} of ALE and port 3. The noise is due to external bus capacitance discharging into the port 0 and port 2 pins when these pins make 1-to-0 transitions during bus operation. In the worst case (capacitive loading > 100 pF), the noise pulse on ALE line may exceed 0.8 V. In such cases it may be desirable to qualify ALE with a schmitt-trigger, or use an address latch with a schmitt-trigger strobe input.
- 2) Capacitive loading on ports 0 and 2 may cause the V_{OH} on ALE and \overline{PSEN} to momentarily fall below the 0.9 V_{CC} specification when the address lines are stabilizing.
- 3) Overload conditions occur if the standard operating conditions are exceeded, i.e. the voltage on any pin exceeds the specified range (i.e. $V_{OV} > V_{CC} + 0.5 V$ or $V_{OV} < V_{SS} - 0.5 V$). The supply voltage V_{CC} and V_{SS} must remain within the specified limits. The absolute sum of input currents on all port pins may not exceed 50 mA.
- 4) Not 100% tested, guaranteed by design characterization.
- 5) Only valid in programming mode.
- 6) I_{CC} (active mode) is measured with:
XTAL1 driven with $t_R/t_F = 5 ns$, 50% duty cycle, $V_{IL} = V_{SS} + 0.5 V$, $V_{IH} = V_{CC} - 0.5 V$; XTAL2 = N.C.;
EA = Port0 = RESET = V_{CC} ; all other pins are disconnected. I_{CC} would be slightly higher if a crystal oscillator is used (approx. 1 mA)
- 7) I_{CC} (idle mode) is measured with all output pins disconnected and with all peripherals disabled;
XTAL1 driven with $t_R/t_F = 5 ns$, 50% duty cycle, $V_{IL} = V_{SS} + 0.5 V$, $V_{IH} = V_{CC} - 0.5 V$; XTAL2 = N.C.;
RESET = $\overline{EA} = V_{SS}$; Port0 = V_{CC} ; all other pins are disconnected;
- 8) I_{CC} (active mode with slow-down mode) is measured : TBD
- 9) I_{CC} (idle mode with slow-down mode) is measured : TBD
- 10) I_{PD} (power-down mode) is measured under following conditions:
 $\overline{EA} = \text{Port 0} = V_{CC}$; RESET = V_{SS} ; XTAL2 = N.C.; XTAL1 = V_{CC} ; $V_{AGND} = V_{SS}$; $V_{AREF} = V_{CC}$;
all other pins are disconnected.
- 11) The typical I_{CC} values are periodically measured at $T_A = +25 \text{ }^\circ C$ but not 100% tested.
- 12) The maximum I_{CC} values are measured under worst case conditions ($T_A = 0 \text{ }^\circ C$ or $-40 \text{ }^\circ C$ and $V_{CC} = 5.5 V$)

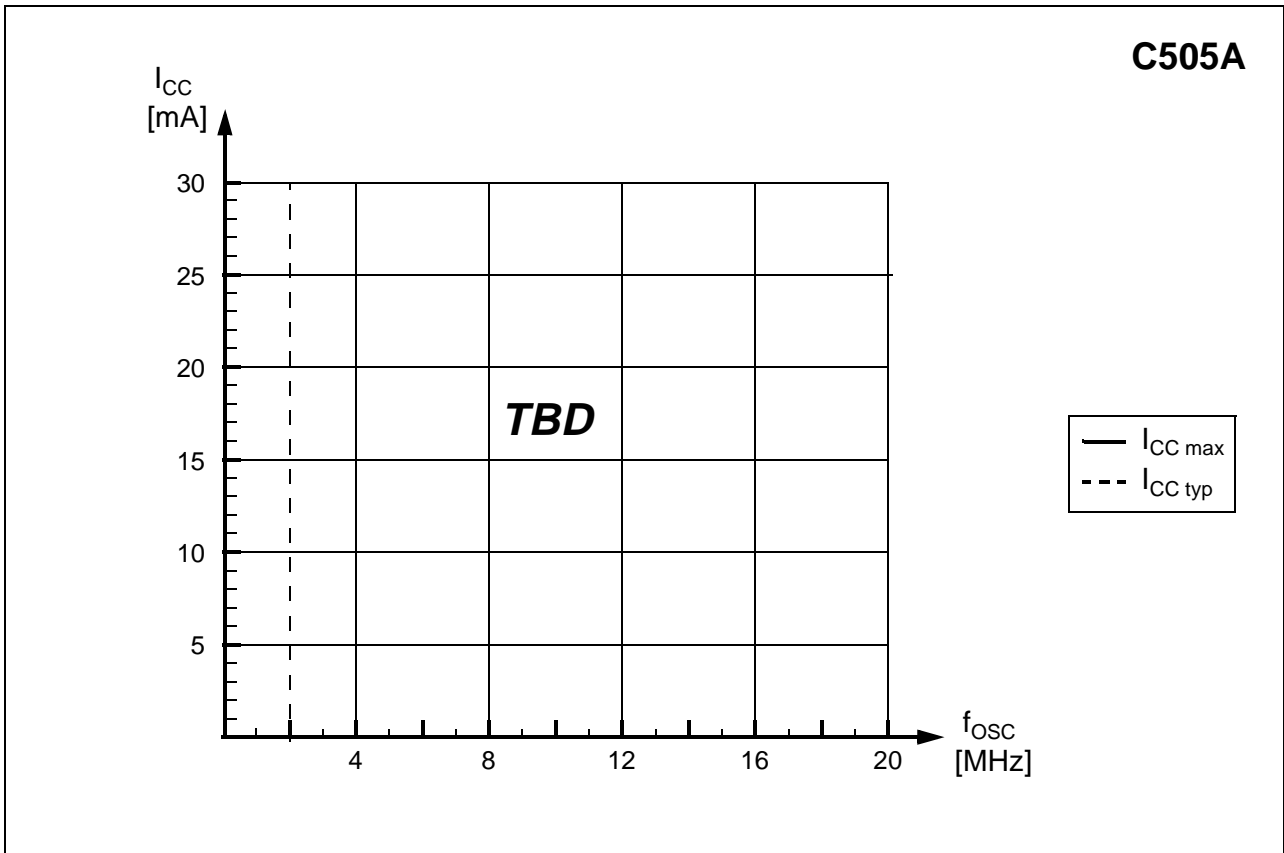

ICC Diagram

C505A : Power Supply Current Calculation Formulas

Parameter	Symbol	Formula
Active mode	$I_{CC\ typ}$	TBD
	$I_{CC\ max}$	TBD
Idle mode	$I_{CC\ typ}$	TBD
	$I_{CC\ max}$	TBD
Active mode with slow-down enabled	$I_{CC\ typ}$	TBD
	$I_{CC\ max}$	TBD
Idle mode with slow-down enabled	$I_{CC\ typ}$	TBD
	$I_{CC\ max}$	TBD

Note : f_{OSC} is the oscillator frequency in MHz. I_{CC} values are given in mA.

5.3 A/D Converter Characteristics

$$V_{CC} = 5\text{ V} + 10\%, -15\%; V_{SS} = 0\text{ V}$$

$$T_A = 0\text{ to }70\text{ }^\circ\text{C}$$

$$T_A = -40\text{ to }85\text{ }^\circ\text{C}$$

$$T_A = -40\text{ to }110\text{ }^\circ\text{C}$$

$$T_A = -40\text{ to }125\text{ }^\circ\text{C}$$

for the SAB-C505A versions

for the SAF-C505A versions

for the SAH-C505A versions

for the SAK-C505A versions

$$4\text{ V} \leq V_{AREF} \leq V_{CC} + 0.1\text{ V}; V_{SS} - 0.1\text{ V} \leq V_{AGND} \leq V_{SS} + 0.2\text{ V}$$

Parameter	Symbol	Limit Values		Unit	Test Condition
		min.	max.		
Analog input voltage	V_{AIN}	V_{AGND}	V_{AREF}	V	1)
Sample time	t_S	–	$64 \times t_{IN}$ $32 \times t_{IN}$ $16 \times t_{IN}$ $8 \times t_{IN}$	ns	Prescaler ÷ 32 Prescaler ÷ 16 Prescaler ÷ 8 Prescaler ÷ 4 2)
Conversion cycle time	t_{ADCC}	–	$384 \times t_{IN}$ $192 \times t_{IN}$ $96 \times t_{IN}$ $48 \times t_{IN}$	ns	Prescaler ÷ 32 Prescaler ÷ 16 Prescaler ÷ 8 Prescaler ÷ 4 3)
Total unadjusted error	T_{UE}	–	± 2	LSB	$V_{SS} + 0.5\text{V} \leq V_{AIN} \leq V_{CC} - 0.5\text{V}$ 4)
		–	± 4	LSB	$V_{SS} < V_{AIN} < V_{CC} + 0.5\text{V}$ $V_{CC} - 0.5\text{V} < V_{AIN} < V_{CC}$ 4)
Internal resistance of reference voltage source	R_{AREF}	–	$t_{ADC} / 250$ - 0.25	k Ω	t_{ADC} in [ns] 5) 6)
Internal resistance of analog source	R_{ASRC}	–	$t_S / 500$ - 0.25	k Ω	t_S in [ns] 2) 6)
ADC input capacitance	C_{AIN}	–	50	pF	6)

Notes see next page.

Clock calculation table :

Clock Prescaler Ratio	ADCL1, 0	t_{ADC}	t_S	t_{ADCC}
÷ 32	1 1	$32 \times t_{IN}$	$64 \times t_{IN}$	$384 \times t_{IN}$
÷ 16	1 0	$16 \times t_{IN}$	$32 \times t_{IN}$	$192 \times t_{IN}$
÷ 8	0 1	$8 \times t_{IN}$	$16 \times t_{IN}$	$96 \times t_{IN}$
÷ 4	0 0	$4 \times t_{IN}$	$8 \times t_{IN}$	$48 \times t_{IN}$

Further timing conditions : $t_{ADC} \text{ min} = 500\text{ ns}$
 $t_{IN} = 1 / f_{OSC} = t_{CLP}$

Notes:

- 1) V_{AIN} may exceed V_{AGND} or V_{AREF} up to the absolute maximum ratings. However, the conversion result in these cases will be $X000_H$ or $X3FF_H$, respectively.
- 2) During the sample time the input capacitance C_{AIN} must be charged/discharged by the external source. The internal resistance of the analog source must allow the capacitance to reach their final voltage level within t_S . After the end of the sample time t_S , changes of the analog input voltage have no effect on the conversion result.
- 3) This parameter includes the sample time t_S , the time for determining the digital result and the time for the calibration. Values for the conversion clock t_{ADC} depend on programming and can be taken from the table on the previous page.
- 4) T_{UE} is tested at $V_{AREF} = 5.0\text{ V}$, $V_{AGND} = 0\text{ V}$, $V_{CC} = 4.9\text{ V}$. It is guaranteed by design characterization for all other voltages within the defined voltage range.
If an overload condition occurs on maximum 2 unused analog input pins and the absolute sum of input overload currents on all analog input pins does not exceed 10 mA, an additional conversion error of 1/2 LSB is permissible.
- 5) During the conversion the ADC's capacitance must be repeatedly charged or discharged. The internal resistance of the reference source must allow the capacitance to reach their final voltage level within the indicated time. The maximum internal resistance results from the programmed conversion timing.
- 6) Not 100% tested, but guaranteed by design characterization.

5.4 AC Characteristics (12 MHz, 0.5 Duty Cycle)

$V_{CC} = 5V +10\%, -15\%$; $V_{SS} = 0 V$

$T_A = 0$ to $70\text{ }^\circ\text{C}$

for the SAB-C505A versions

$T_A = -40$ to $85\text{ }^\circ\text{C}$

for the SAF-C505A versions

$T_A = -40$ to $110\text{ }^\circ\text{C}$

for the SAH-C505A versions

$T_A = -40$ to $125\text{ }^\circ\text{C}$

for the SAK-C505A versions

(C_L for port 0, ALE and $\overline{\text{PSEN}}$ outputs = 100 pF; C_L for all other outputs = 80 pF)

Program Memory Characteristics

Parameter	Symbol	Limit Values				Unit
		12 MHz clock 0.5 Duty Cycle		Variable Clock 1/CLP = 2 MHz to 12 MHz		
		min.	max.	min.	max.	
ALE pulse width	t_{LHLL}	43	–	CLP - 40	–	ns
Address setup to ALE	t_{AVLL}	17	–	CLP/2 - 25	–	ns
Address hold after ALE	t_{LLAX}	17	–	CLP/2 - 25	–	ns
ALE to valid instruction in	t_{LLIV}	–	80	–	2 CLP - 87	ns
ALE to $\overline{\text{PSEN}}$	t_{LLPL}	22	–	CLP/2 - 20	–	ns
$\overline{\text{PSEN}}$ pulse width	t_{PLPH}	95	–	3/2 CLP - 30	–	ns
$\overline{\text{PSEN}}$ to valid instruction in	t_{PLIV}	–	60	–	3/2 CLP - 65	ns
Input instruction hold after $\overline{\text{PSEN}}$	t_{PXIX}	0	–	0	–	ns
Input instruction float after $\overline{\text{PSEN}}$	$t_{PXIZ}^*)$	–	32	–	CLP/2 - 10	ns
Address valid after $\overline{\text{PSEN}}$	$t_{PXAV}^*)$	37	–	CLP/2 - 5	–	ns
Address to valid instruction in	t_{AVIV}	–	148	–	5/2 CLP - 60	ns
Address float to $\overline{\text{PSEN}}$	t_{AZPL}	0	–	0	–	ns

^{*)} Interfacing the C505A to devices with float times up to 37 ns is permissible. This limited bus contention will not cause any damage to port 0 drivers.

AC Characteristics (12 MHz, 0.5 Duty Cycle, cont'd)

External Data Memory Characteristics

Parameter	Symbol	Limit Values				Unit
		12 MHz clock 0.5 Duty Cycle		Variable Clock 1/CLP = 2 MHz to 12 MHz		
		min.	max.	min.	max.	
\overline{RD} pulse width	t_{RLRH}	180	–	3 CLP - 70	–	ns
\overline{WR} pulse width	t_{WLWH}	180	–	3 CLP - 70	–	ns
Address hold after ALE	t_{LLAX2}	56	–	CLP - 27	–	ns
\overline{RD} to valid data in	t_{RLDV}	–	118	–	5/2 CLP - 90	ns
Data hold after \overline{RD}	t_{RHDX}	0	–	0	–	ns
Data float after \overline{RD}	t_{RHDZ}	–	63	–	CLP - 20	ns
ALE to valid data in	t_{LLDV}	–	200	–	4 CLP - 133	ns
Address to valid data in	t_{AVDV}	–	220	–	9/2 CLP - 155	ns
ALE to \overline{WR} or \overline{RD}	t_{LLWL}	75	175	3/2 CLP - 50	3/2 CLP + 50	ns
Address valid to \overline{WR}	t_{AVWL}	70	–	2 CLP - 97	–	ns
\overline{WR} or \overline{RD} high to ALE high	t_{WHLH}	17	67	CLP/2 - 25	CLP/2 + 25	ns
Data valid to \overline{WR} transition	t_{QVWX}	5	–	CLP/2 - 37	–	ns
Data setup before \overline{WR}	t_{QVWH}	170	–	7/2 CLP - 122	–	ns
Data hold after \overline{WR}	t_{WHQX}	15	–	CLP/2 - 27	–	ns
Address float after \overline{RD}	t_{RLAZ}	–	0	–	0	ns

External Clock Drive Characteristics

Parameter	Symbol	Limit Values		Unit
		Variable Clock Freq. = 2 MHz to 12 MHz		
		min.	max.	
Oscillator period	CLP	83.3	500	ns
High time	TCL_H	20	$CLP - TCL_L$	ns
Low time	TCL_L	20	$CLP - TCL_H$	ns
Rise time	t_R	–	12	ns
Fall time	t_F	–	12	ns
Oscillator duty cycle	DC	0.5	0.5	–

5.5 AC Characteristics (16 MHz, 0.4 to 0.6 Duty Cycle)

$V_{CC} = 5V +10\%, -15\%$; $V_{SS} = 0 V$

$T_A = 0 \text{ to } 70 \text{ }^\circ\text{C}$

for the SAB-C505A versions

$T_A = -40 \text{ to } 85 \text{ }^\circ\text{C}$

for the SAF-C505A versions

(C_L for port 0, ALE and $\overline{\text{PSEN}}$ outputs = 100 pF; C_L for all other outputs = 80 pF)

Program Memory Characteristics

Parameter	Symbol	Limit Values				Unit
		16-MHz clock Duty Cycle 0.4 to 0.6		Variable Clock 1/CLP= 2 MHz to 16 MHz		
		min.	max.	min.	max.	
ALE pulse width	t_{LHLL}	48	–	CLP - 15	–	ns
Address setup to ALE	t_{AVLL}	10	–	$TCL_{Hmin} - 15$	–	ns
Address hold after ALE	t_{LLAX}	10	–	$TCL_{Hmin} - 15$	–	ns
ALE to valid instruction in	t_{LLIV}	–	75	–	2 CLP - 50	ns
ALE to $\overline{\text{PSEN}}$	t_{LLPL}	10	–	$TCL_{Lmin} - 15$	–	ns
$\overline{\text{PSEN}}$ pulse width	t_{PLPH}	73	–	CLP+ $TCL_{Hmin} - 15$	–	ns
$\overline{\text{PSEN}}$ to valid instruction in	t_{PLIV}	–	38	–	CLP+ $TCL_{Hmin} - 50$	ns
Input instruction hold after $\overline{\text{PSEN}}$	t_{PXIX}	0	–	0	–	ns
Input instruction float after $\overline{\text{PSEN}}$	$t_{PXIZ}^*)$	–	15	–	$TCL_{Lmin} - 10$	ns
Address valid after $\overline{\text{PSEN}}$	$t_{PXAV}^*)$	20	–	$TCL_{Lmin} - 5$	–	ns
Address to valid instruction in	t_{AVIV}	–	95	–	2 CLP + $TCL_{Hmin} - 55$	ns
Address float to $\overline{\text{PSEN}}$	t_{AZPL}	-5	–	-5	–	ns

^{*)} Interfacing the C505A to devices with float times up to 20 ns is permissible. This limited bus contention will not cause any damage to port 0 drivers.

AC Characteristics (16 MHz, 0.4 to 0.6 Duty Cycle, cont'd)

External Data Memory Characteristics

Parameter	Symbol	Limit Values				Unit
		16-MHz clock Duty Cycle 0.4 to 0.6		Variable Clock 1/CLP= 2 MHz to 16 MHz		
		min.	max.	min.	max.	
\overline{RD} pulse width	t_{RLRH}	158	–	3 CLP - 30	–	ns
\overline{WR} pulse width	t_{WLWH}	158	–	3 CLP - 30	–	ns
Address hold after ALE	t_{LLAX2}	48	–	CLP - 15	–	ns
\overline{RD} to valid data in	t_{RLDV}	–	100	–	2 CLP+ $TCL_{Hmin} - 50$	ns
Data hold after \overline{RD}	t_{RHDX}	0	–	0	–	ns
Data float after \overline{RD}	t_{RHDZ}	–	51	–	CLP - 12	ns
ALE to valid data in	t_{LLDV}	–	200	–	4 CLP - 50	ns
Address to valid data in	t_{AVDV}	–	200	–	4 CLP + $TCL_{Hmin} - 75$	ns
ALE to \overline{WR} or \overline{RD}	t_{LLWL}	73	103	CLP + $TCL_{Lmin} - 15$	CLP+ $TCL_{Lmin} + 15$	ns
Address valid to \overline{WR}	t_{AVWL}	95	–	2 CLP - 30	–	ns
\overline{WR} or \overline{RD} high to ALE high	t_{WHLH}	10	40	$TCL_{Hmin} - 15$	$TCL_{Hmin} + 15$	ns
Data valid to \overline{WR} transition	t_{QVWX}	5	–	$TCL_{Lmin} - 20$	–	ns
Data setup before \overline{WR}	t_{QVWH}	163	–	3 CLP + $TCL_{Lmin} - 50$	–	ns
Data hold after \overline{WR}	t_{WHQX}	5	–	$TCL_{Hmin} - 20$	–	ns
Address float after \overline{RD}	t_{RLAZ}	–	0	–	0	ns

AC Characteristics (16 MHz, 0.4 to 0.6 Duty Cycle, cont'd)

External Clock Drive Characteristics

Parameter	Symbol	CPU Clock = 16 MHz Duty Cycle 0.4 to 0.6		Variable CPU Clock 1/CLP = 2 to 16 MHz		Unit
		min.	max.	min.	max.	
Oscillator period	CLP	62.5	62.5	62.5	500	ns
High time	TCL _H	25	–	25	CLP - TCL _L	ns
Low time	TCL _L	25	–	25	CLP - TCL _H	ns
Rise time	t _R	–	10	–	10	ns
Fall time	t _F	–	10	–	10	ns
Oscillator duty cycle	DC	0.4	0.6	25 / CLP	1 - 25 / CLP	–
Clock cycle	TCL	25	37.5	CLP * DC _{min}	CLP * DC _{max}	ns

Note: The 16 MHz values in the tables are given as an example for a typical duty cycle variation of the oscillator clock from 0.4 to 0.6.

5.6 AC Characteristics (20 MHz, 0.5 Duty Cycle)

$V_{CC} = 5V +10\%, -15\%$; $V_{SS} = 0 V$

$T_A = 0$ to $70\text{ }^\circ\text{C}$

for the SAB-C505A versions

$T_A = -40$ to $85\text{ }^\circ\text{C}$

for the SAF-C505A versions

(C_L for port 0, ALE and $\overline{\text{PSEN}}$ outputs = 100 pF; C_L for all other outputs = 80 pF)

Program Memory Characteristics

Parameter	Symbol	Limit Values				Unit
		20 MHz clock 0.5 Duty Cycle		Variable Clock 1/CLP = 2 MHz to 20 MHz		
		min.	max.	min.	max.	
ALE pulse width	t_{LHLL}	35	–	CLP - 15	–	ns
Address setup to ALE	t_{AVLL}	10	–	CLP/2 - 15	–	ns
Address hold after ALE	t_{LLAX}	10	–	CLP/2 - 15	–	ns
ALE to valid instruction in	t_{LLIV}	–	55	–	2 CLP - 45	ns
ALE to $\overline{\text{PSEN}}$	t_{LLPL}	10	–	CLP/2 - 15	–	ns
$\overline{\text{PSEN}}$ pulse width	t_{PLPH}	60	–	3/2 CLP - 15	–	ns
$\overline{\text{PSEN}}$ to valid instruction in	t_{PLIV}	–	25	–	3/2 CLP - 50	ns
Input instruction hold after $\overline{\text{PSEN}}$	t_{PXIX}	0	–	0	–	ns
Input instruction float after $\overline{\text{PSEN}}$	t_{PXIZ} *)	–	20	–	CLP/2 - 5	ns
Address valid after $\overline{\text{PSEN}}$	t_{PXAV} *)	20	–	CLP/2 - 5	–	ns
Address to valid instruction in	t_{AVIV}	–	65	–	5/2 CLP - 60	ns
Address float to $\overline{\text{PSEN}}$	t_{AZPL}	- 5	–	- 5	–	ns

*) Interfacing the C505A to devices with float times up to 20 ns is permissible. This limited bus contention will not cause any damage to port 0 drivers.

AC Characteristics (20 MHz, 0.5 Duty Cycle, cont'd)

External Data Memory Characteristics

Parameter	Symbol	Limit Values				Unit
		20 MHz clock 0.5 Duty Cycle		Variable Clock 1/CLP = 2 MHz to 20 MHz		
		min.	max.	min.	max.	
\overline{RD} pulse width	t_{RLRH}	120	–	3 CLP - 30	–	ns
\overline{WR} pulse width	t_{WLWH}	120	–	3 CLP - 30	–	ns
Address hold after ALE	t_{LLAX2}	35	–	CLP - 15	–	ns
\overline{RD} to valid data in	t_{RLDV}	–	75	–	5/2 CLP - 50	ns
Data hold after \overline{RD}	t_{RHDX}	0	–	0	–	ns
Data float after \overline{RD}	t_{RHDZ}	–	38	–	CLP - 12	ns
ALE to valid data in	t_{LLDV}	–	150	–	4 CLP - 50	ns
Address to valid data in	t_{AVDV}	–	150	–	9/2 CLP - 75	ns
ALE to \overline{WR} or \overline{RD}	t_{LLWL}	60	90	3/2 CLP - 15	3/2 CLP + 15	ns
Address valid to \overline{WR}	t_{AVWL}	70	–	2 CLP - 30	–	ns
\overline{WR} or \overline{RD} high to ALE high	t_{WHLH}	10	40	CLP/2 - 15	CLP/2 + 15	ns
Data valid to \overline{WR} transition	t_{QVWX}	5	–	CLP/2 - 20	–	ns
Data setup before \overline{WR}	t_{QVWH}	125	–	7/2 CLP - 50	–	ns
Data hold after \overline{WR}	t_{WHQX}	5	–	CLP/2 - 20	–	ns
Address float after \overline{RD}	t_{RLAZ}	–	0	–	0	ns

External Clock Drive Characteristics

Parameter	Symbol	Limit Values		Unit
		Variable Clock Freq. = 2 MHz to 20 MHz		
		min.	max.	
Oscillator period	CLP	50	500	ns
High time	TCL_H	15	$CLP - TCL_L$	ns
Low time	TCL_L	15	$CLP - TCL_H$	ns
Rise time	t_R	–	10	ns
Fall time	t_F	–	10	ns
Oscillator duty cycle	DC	0.5	0.5	–

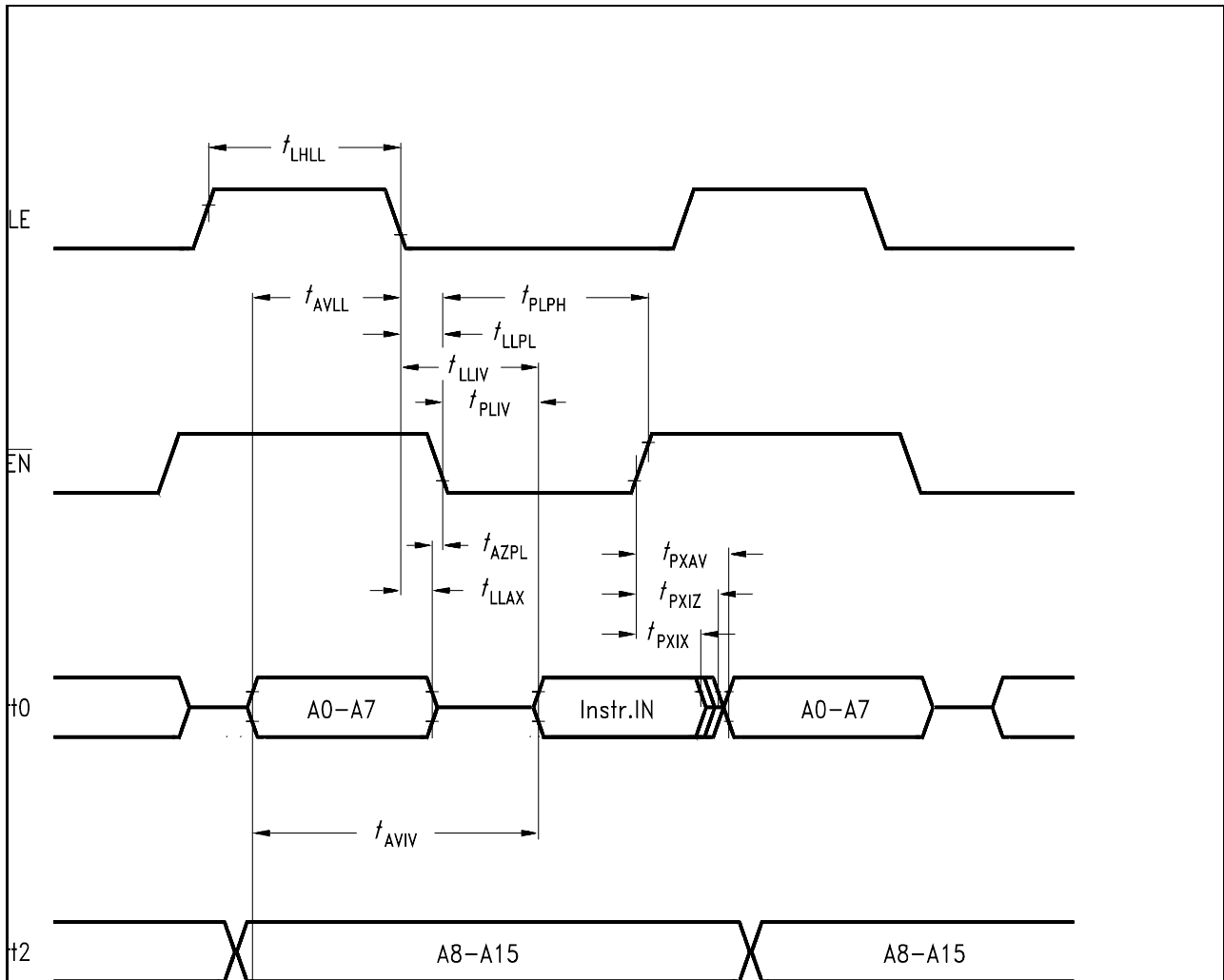

Program Memory Read Cycle

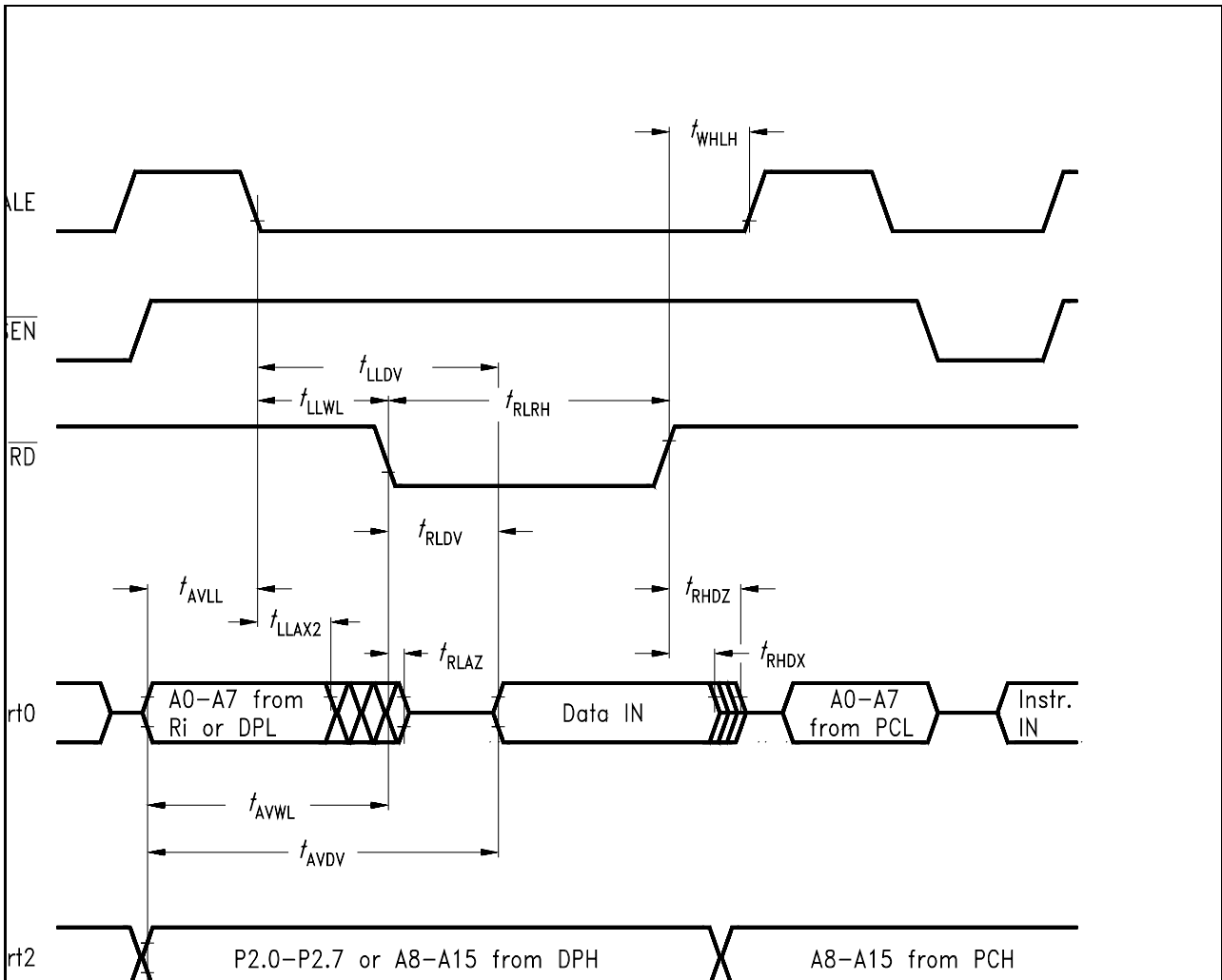

Data Memory Read Cycle

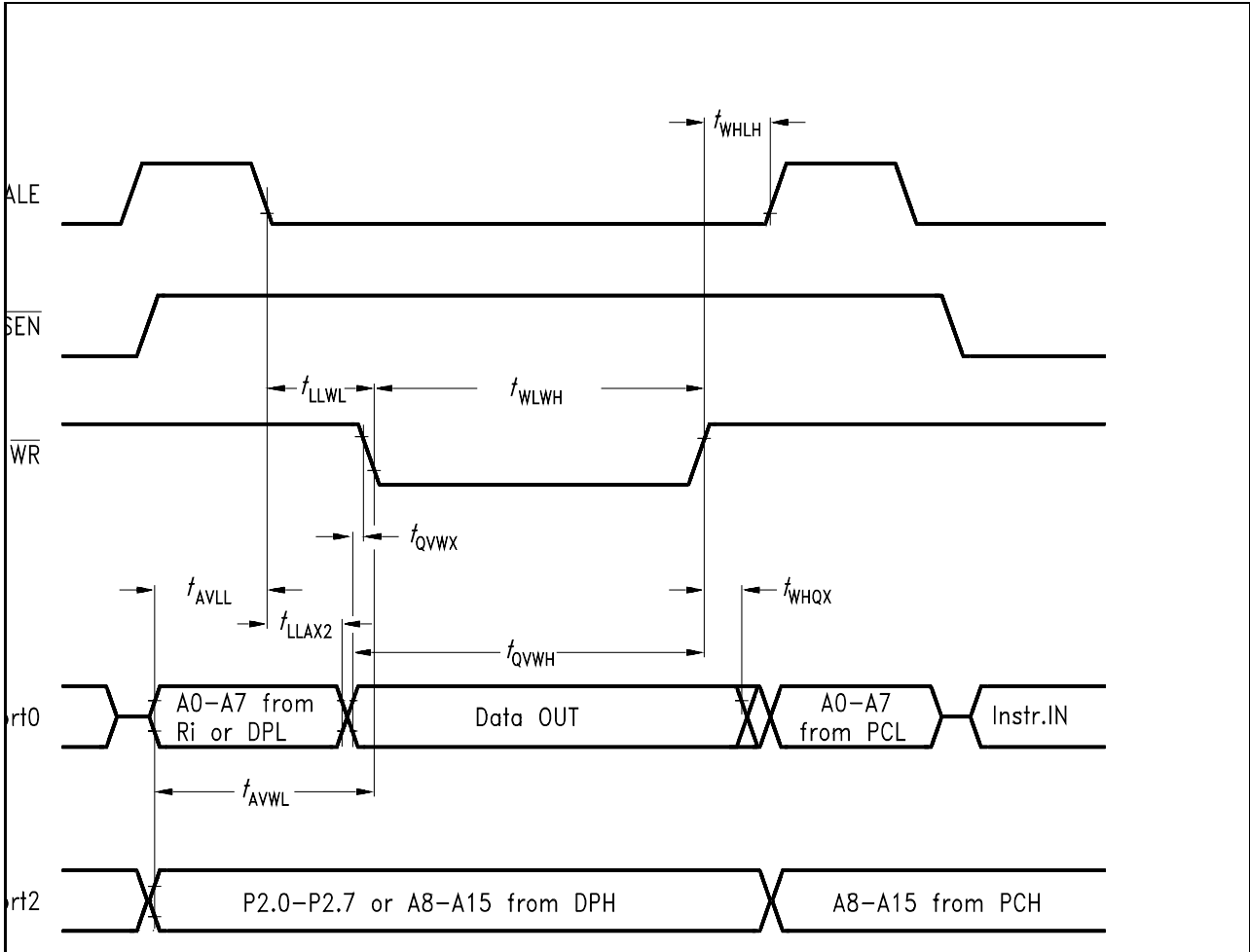

Data Memory Write Cycle

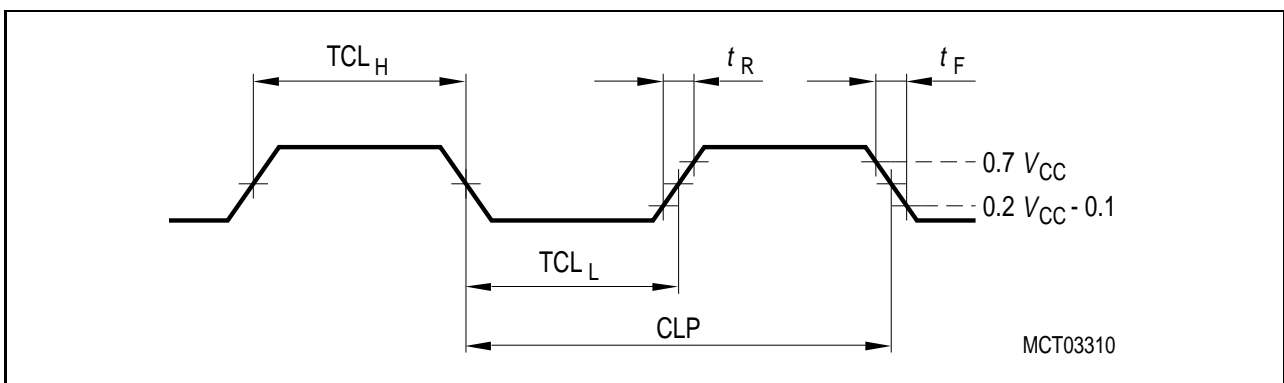

External Clock Drive on XTAL1

5.7 OTP Memory Characteristics

5.7.1 Programming Mode Timing Characteristics

$V_{CC} = 5\text{ V} \pm 10\%$; $V_{PP} = 11.5\text{ V} \pm 5\%$; $T_A = 25\text{ }^\circ\text{C} \pm 10\text{ }^\circ\text{C}$

Parameter	Symbol	Limit Values		Unit
		min.	max.	
PALE pulse width	t_{PAW}	35	–	ns
PMSEL setup to PALE rising edge	t_{PMS}	10	–	
Address setup to PALE, \overline{PROG} , or \overline{PRD} falling edge	t_{PAS}	10	–	ns
Address hold after PALE, \overline{PROG} , or \overline{PRD} falling edge	t_{PAH}	10	–	ns
Address, data setup to \overline{PROG} or \overline{PRD}	t_{PCS}	100	–	ns
Address, data hold after \overline{PROG} or \overline{PRD}	t_{PCH}	0	–	ns
PMSEL setup to \overline{PROG} or \overline{PRD}	t_{PMS}	10	–	ns
PMSEL hold after \overline{PROG} or \overline{PRD}	t_{PMH}	10	–	ns
\overline{PROG} pulse width	t_{PWW}	100	–	μs
\overline{PRD} pulse width	t_{PRW}	100	–	ns
Address to valid data out	t_{PAD}	–	75	ns
\overline{PRD} to valid data out	t_{PRD}	–	20	ns
Data hold after \overline{PRD}	t_{PDH}	0	–	ns
Data float after \overline{PRD}	t_{PDF}	–	20	ns
\overline{PROG} high between two consecutive \overline{PROG} low pulses	t_{PWH1}	1	–	μs
\overline{PRD} high between two consecutive \overline{PRD} low pulses	t_{PWH2}	100		ns
XTAL clock period	t_{CLKP}	83.3	500	ns

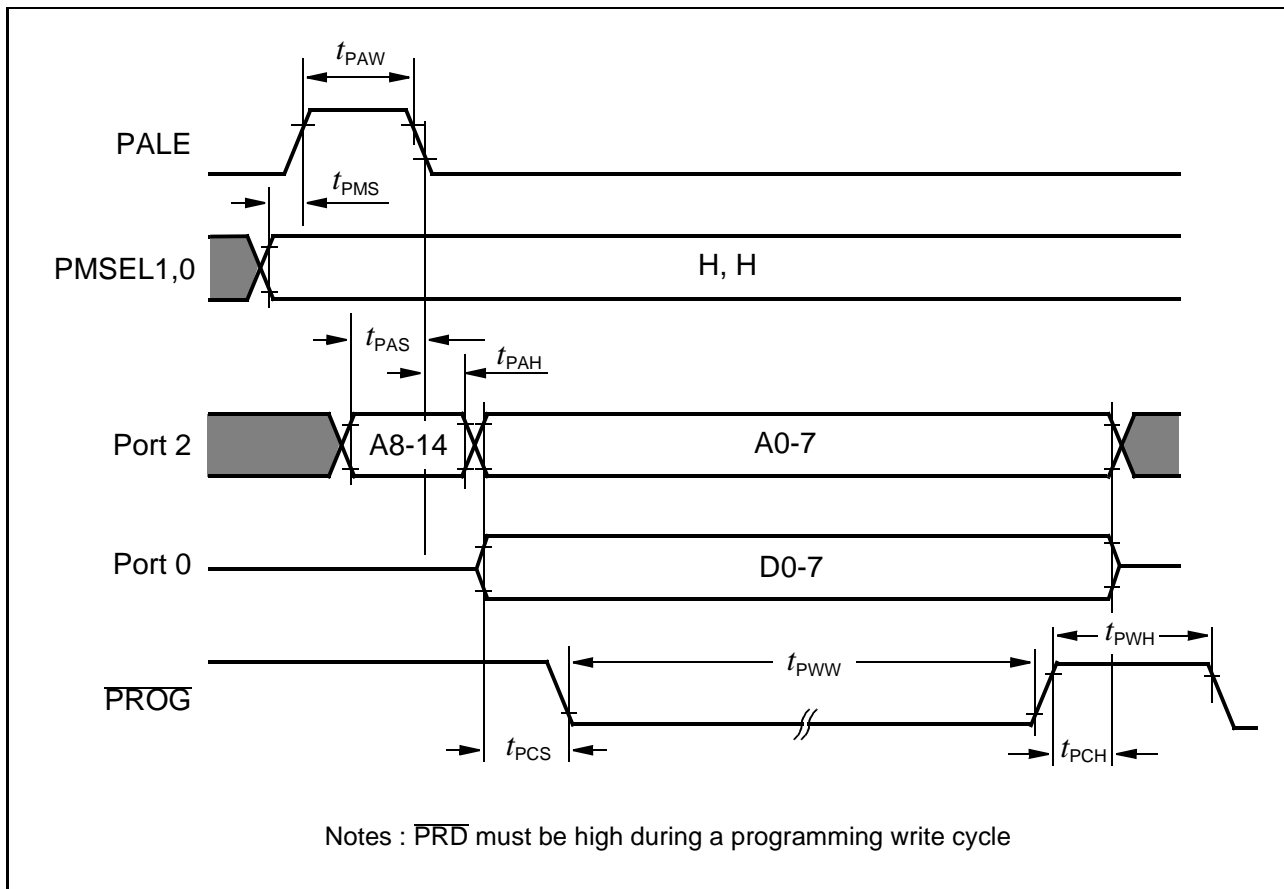

Programming Code Byte - Write Cycle Timing

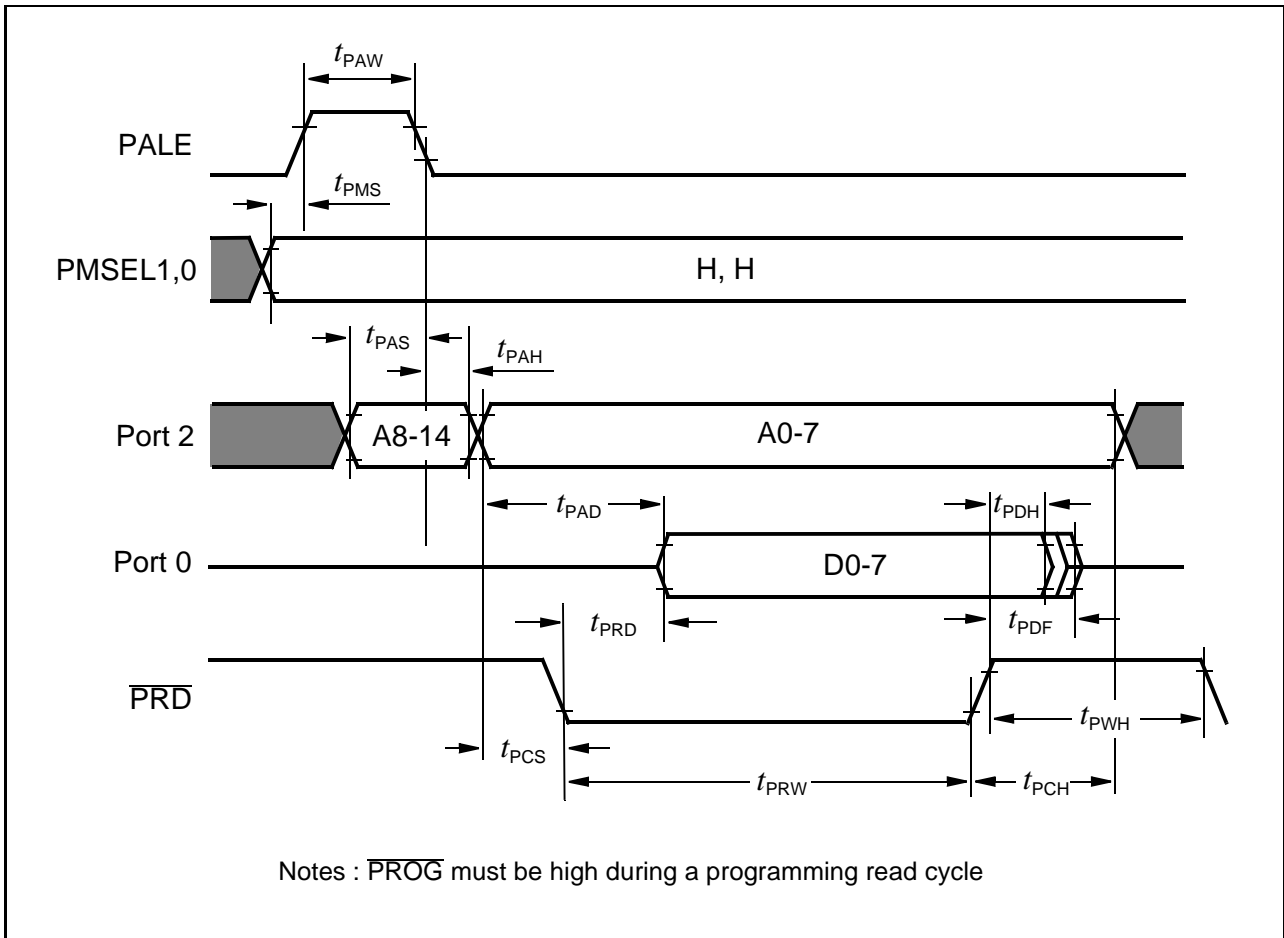

Verify Code Byte - Read Cycle Timing

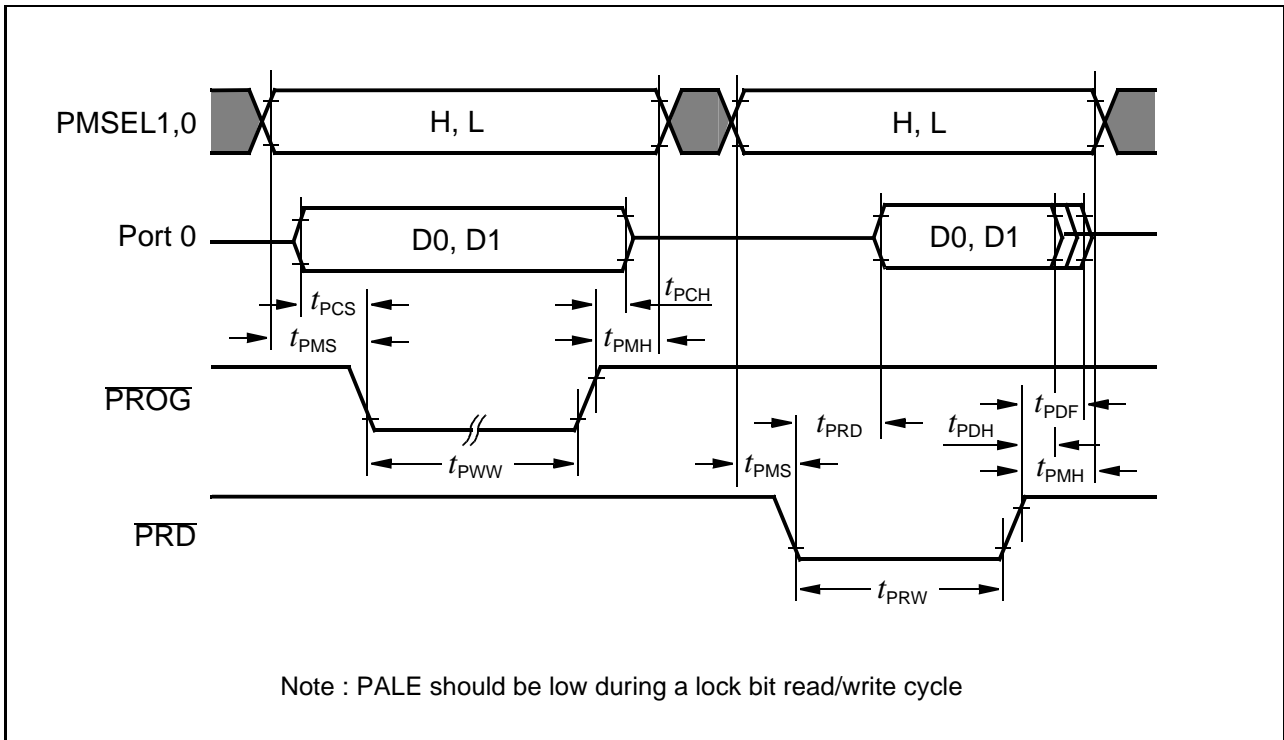

Lock Bit Access Timing

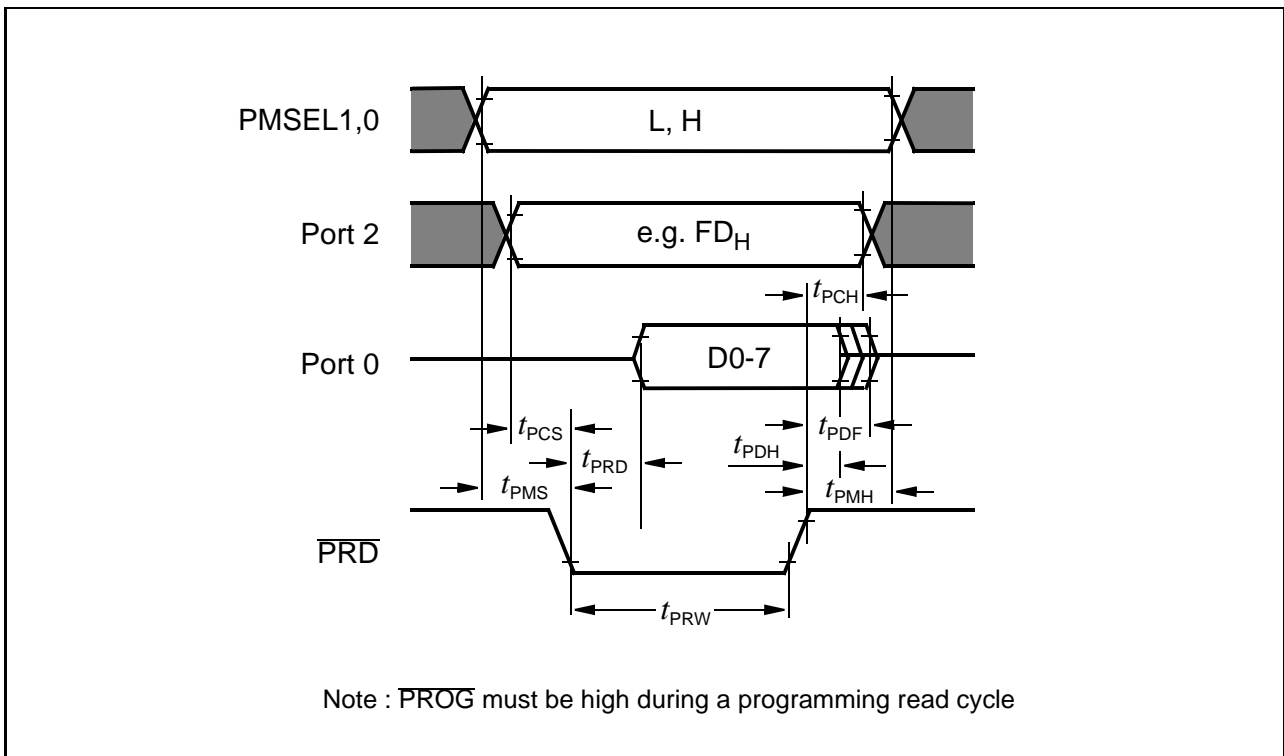

Version Registers - Read Timing

5.7.2 OTP Verification Mode Characteristics

Parameter	Symbol	Limit Values			Unit
		min.	typ	max.	
ALE pulse width	t_{AWD}	–	CLP	–	ns
ALE period	t_{ACY}	–	6 CLP	–	ns
Data valid after ALE	t_{DVA}	–	–	2 CLP	ns
Data stable after ALE	t_{DSA}	4 CLP	–	–	ns
P3.5 setup to ALE low	t_{AS}	–	TCL_H	–	ns
Oscillator frequency	1/ CLP	4	–	6	MHz

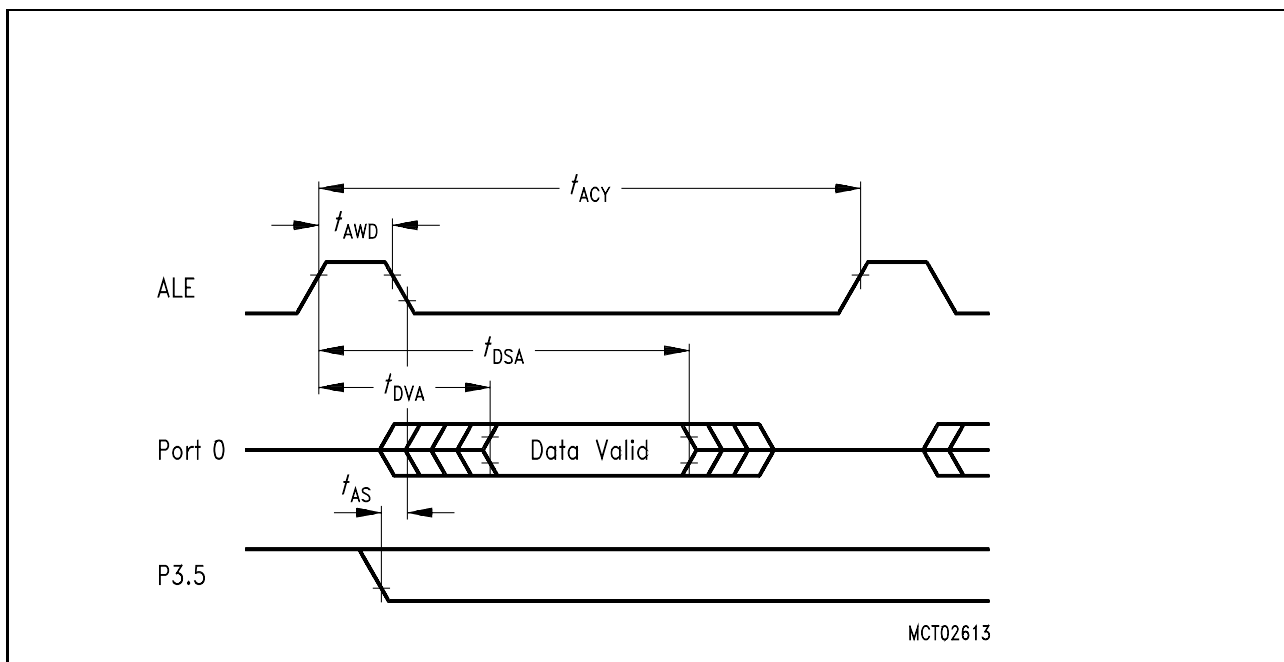

OTP Verification Mode

Note: This mode cannot be entered into if OTP protection levels of 1 to 3 are programmed.

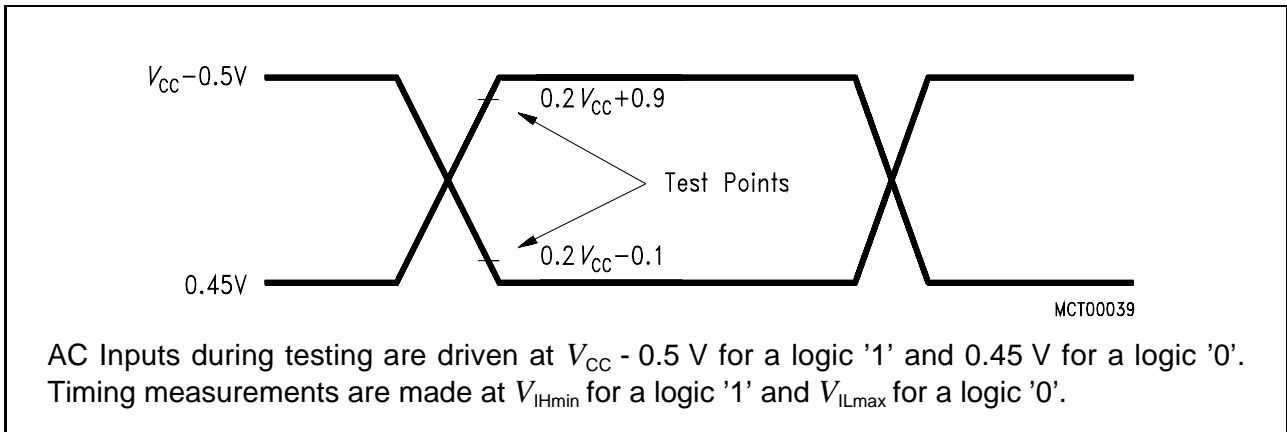

AC Testing: Input, Output Waveforms

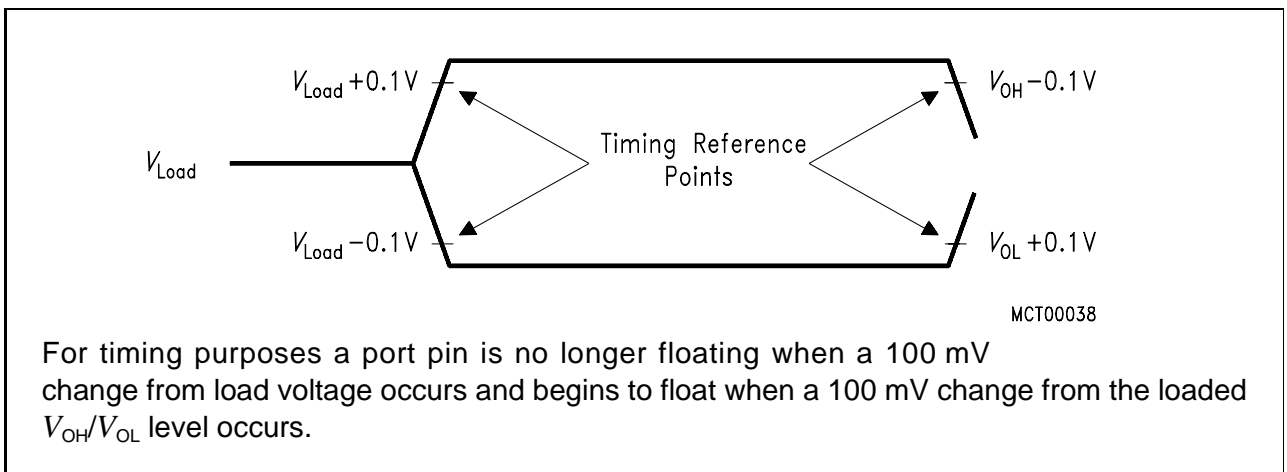

AC Testing : Float Waveforms

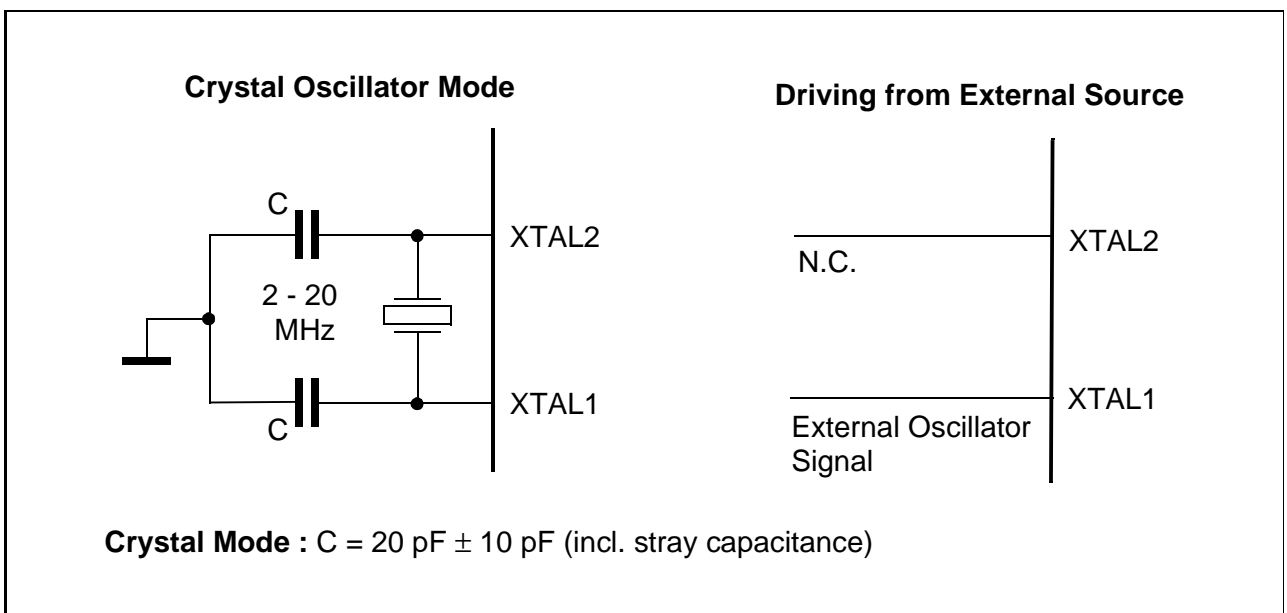

Recommended Oscillator Circuits for Crystal Oscillator

5.8 Package Information

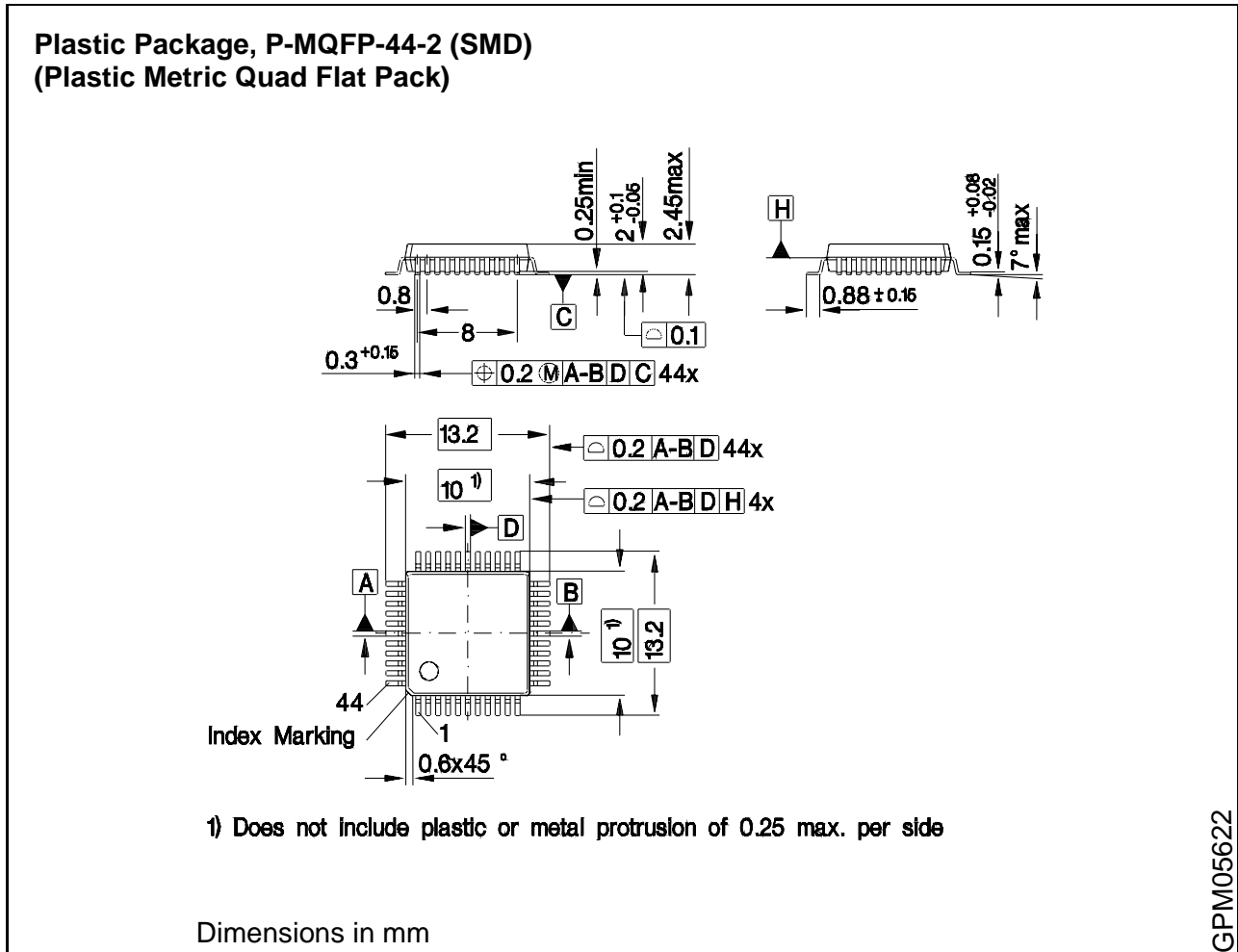

P-MQFP-44-2 Outline

Sorts of Packing

Package outlines for tubes, trays etc. are contained in our Data Book "Package Information".

SMD = Surface Mounted Device

6 Index

Note: Bold page numbers refer to the main definition part of SFRs or SFR bits.

A

A/D converter	3-1–3-13
Analog input pin selection	3-13
Block diagram	3-2
Calibration mechanisms	3-12
Clock selection	3-7
Conversion time calculation	3-10
Conversion timing	3-8
General operation	3-1
Registers	3-3–3-6
System clock relationship	3-9
A/D converter characteristics	5-5–5-6
Absolute maximum ratings	5-1
AC	2-8
AC characteristics	5-7–5-13
12 MHz Timing	5-7–5-8
16 MHz Timing	5-9–5-11
20 MHz Timing	5-12–5-13
AC Testing	
Float waveforms	5-22
Input/output waveforms	5-22
ACC	2-4, 2-9
ADCL1	2-9
ADCL1-0	3-5
ADCON0	2-4, 2-5, 2-9, 3-4
ADCON1	2-4, 2-9, 3-4
ADDATH	2-4, 2-9, 3-3
ADDATL	2-4, 2-9, 3-3
ADM	2-9, 3-4

B

B	2-4, 2-9
BD	2-9
BOFF	2-10
BRP	2-10
BSY	2-9, 3-4
BTR0	2-6, 2-10
BTR1	2-6, 2-10

C

C/T	2-7
CCE	2-10
CCEN	2-5, 2-8
CCH1	2-5, 2-8
CCH2	2-5, 2-8

CCH3	2-5, 2-8
CCL1	2-5, 2-8
CCL2	2-5, 2-8
CCL3	2-5, 2-8
CLK	2-9
CLKOUT	2-7
CMOD	2-8
COCAH0	2-8
COCAH1	2-8
COCAH2	2-8
COCAH3	2-8
COCAL0	2-8
COCAL1	2-8
COCAL2	2-8
COCAL3	2-8
CPUUPD	2-10
CR	2-6, 2-10
CRCH	2-5
CRCL	2-5
CSWO	2-3, 2-8
CY	2-8

D

DB0	2-6, 2-11
DB1	2-6, 2-11
DB2	2-6, 2-11
DB3	2-6, 2-11
DB4	2-6, 2-11
DB5	2-6, 2-11
DB6	2-6, 2-11
DB7	2-6, 2-11
DC characteristics	5-2–5-3
Device Characteristics	5-1–5-23
DIR	2-10
DLC	2-10
DPH	2-4, 2-7
DPL	2-4, 2-7
DPSEL	2-4, 2-7

E

EA	2-7
EADC	2-8, 3-6
EALE	1-8, 2-8
EAN0	2-7
EAN1	2-7
EAN2	2-7
EAN3	2-7
EAN4	2-7
EAN5	2-7

EAN6	2-7	IEX4	2-8
EAN7	2-7	IEX5	2-8
EAN7-0	3-13	IEX6	2-8
ECAN	2-8	INIT	2-10
EIE	2-10	INT0	2-8
ES	2-7	INT1	2-8
ET0	2-7	INT4	2-7
ET1	2-7	INT5	2-7
ET2	2-7	INTID	2-10
EWPD	2-7	INTPND	2-10
EWRN	2-10	IP0	2-4, 2-5, 2-7
EX0	2-7	IP1	2-4, 2-8
EX1	2-7	IR	2-6, 2-10
EX3	2-8	IRCON	2-4, 2-8, 3-6
EX4	2-8	IT0	2-7
EX5	2-8	IT1	2-7
EX6	2-8		
EXEN2	2-8	L	
EXF2	2-8	LAR0	2-6, 2-10
F		LAR1	2-6, 2-10
F0	2-8	LEC0	2-10
F1	2-8	LEC1	2-10
Features	1-2	LEC2	2-10
Functional units	1-1	LGML0	2-6, 2-10
G		LGML1	2-6, 2-10
GATE	2-7	LMLM0	2-6, 2-10
GF0	2-7	LMLM1	2-6, 2-10
GF1	2-7	Logic symbol	1-3
GMS0	2-6, 2-10	M	
GMS1	2-6, 2-10	M0	2-7
I		M1	2-7
I3FR	2-8	MCFG	2-6, 2-10
IADC	2-8	MCR0	2-6, 2-10
ID12	2-10	MCR1	2-6, 2-10
ID17	2-10	Memory organization	2-1
ID20	2-10	Data memory	2-2
ID28	2-10	General purpose registers	2-2
ID4	2-10	Memory map	2-1
IDLE	2-7	Program memory	2-2
IDL5	2-7	MSGLST	2-10
IE	2-10	MSGVAL	2-10
IE0	2-7	MX0	2-9
IE1	2-7	MX1	2-9
IEN0	2-4, 2-5, 2-7	MX2	2-9
IEN1	2-4, 2-5, 2-8, 3-6	MX2-0	3-4
IEX3	2-8	N	
		NEWDAT	2-10

O

OTP memory	4-1–4-13
Basic Mode Selection	4-5
Pin Configuration	4-1
Program/read operation	4-7
OTP Protection	
Protected Verification Mode	4-12
Verification example	4-13
Verification timing	4-12
OV	2-8
OWDS	2-7

P

P	2-8
P0	2-4, 2-7
P1	2-4, 2-7
P1ANA	2-4, 2-7, 3-13
P2	2-4, 2-7
P3	2-4, 2-8
P4	2-4, 2-9
Package information	5-23
PCON	2-5, 2-7
PCON1	2-5, 2-7
PDE	2-7
PDS	2-7
Pin Configuration	1-4
Pin Definitions and functions (Normal Mode)	1-5–1-9
Pin Definitions and functions (OTP Mode)	4-3–4-4
PSW	2-4, 2-8

R

RB8	2-7
RD	2-8
Recommended oscillator circuits	5-22
REN	2-7
RI	2-7
RMAP	2-8
RMTPND	2-10
RS0	2-8
RS1	2-8
RxD	2-8
RXDC	2-9
RXIE	2-10
RXOK	2-10

S

SBUF	2-5, 2-7
------	----------

SCON	2-4, 2-5, 2-7
SD	2-7
SIE	2-10
SJW	2-10
SM0	2-7
SM1	2-7
SM2	2-7
SMOD	2-7
SP	2-4, 2-7
Special Function Registers	2-3
Access with RMAP	2-3
CAN registers - address ordered	2-10–2-11
Table - address ordered	2-7–2-9
Table - functional order	2-4–2-6
SR	2-6, 2-10
SRELH	2-5, 2-8
SRELL	2-5, 2-7
SWDT	2-8
SWI	2-8
SYSCON	2-3, 2-4, 2-8

T

T0	2-8
T1	2-8
T2	2-7
T2CM	2-8
T2CON	2-4, 2-5, 2-8
T2EX	2-7
T2I0	2-8
T2I1	2-8
T2PS	2-8
T2R0	2-8
T2R1	2-8
TB8	2-7
TCON	2-4, 2-5, 2-7
TEST	2-10
TF0	2-7
TF1	2-7
TF2	2-8
TH0	2-5, 2-7
TH1	2-5, 2-7
TH2	2-5, 2-8
TI	2-7
Timings	
Data memory read cycle	5-15
Data memory write cycle	5-16
External clock timing	5-16

OTP verification mode	5-21
Program memory read cycle	5-14
TL0	2-5, 2-7
TL1	2-5, 2-7
TL2	2-5, 2-8
TMOD	2-5, 2-7
TR0	2-7
TR1	2-7
TSEG1	2-10
TSEG2	2-10
TxD	2-8
TXDC	2-9
TXIE	2-10
TXOK	2-10
TXRQ	2-10

U

UAR0	2-6, 2-10
UAR1	2-6, 2-10
UGML0	2-6, 2-10
UGML1	2-6, 2-10
UMLM0	2-6, 2-10
UMLM1	2-6, 2-10

V

VR0	2-4, 2-9
VR1	2-4, 2-9
VR2	2-4, 2-9

W

WDT	2-7
WDTPSEL	2-7
WDTREL	2-5, 2-7
WDTS	2-7
WR	2-8
WS	2-7

X

XMAP0	2-8
XMAP1	2-8
XPAGE	2-4, 2-7
XTD	2-10